

Large Power Transformers from Korea

Investigation No. 731-TA-1189 (Review)

Publication 4826

September 2018

U.S. International Trade Commission

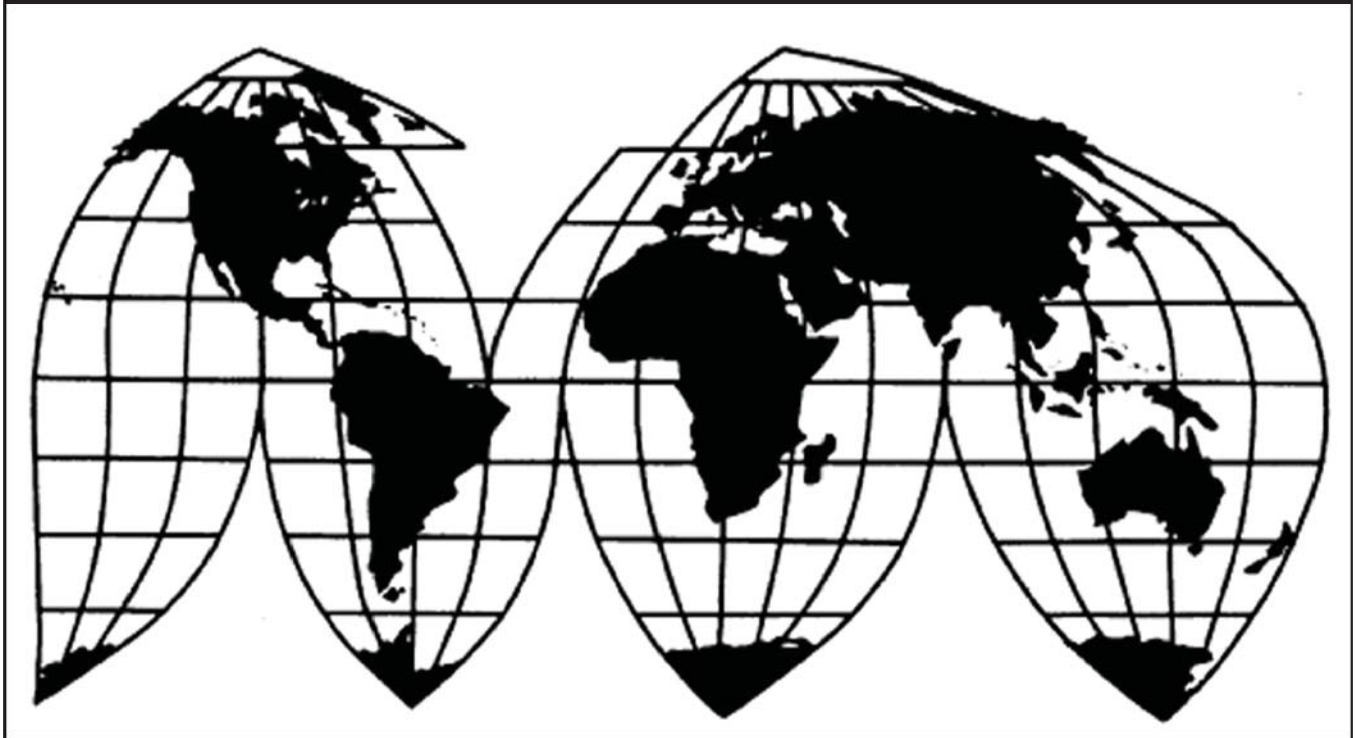

Washington, DC 20436

U.S. International Trade Commission

COMMISSIONERS

David S. Johanson, Chairman

Irving A. Williamson

Meredith M. Broadbent

Rhonda K. Schmidlein

Jason E. Kearns

Catherine DeFilippo
Director of Operations

Staff assigned

Nathanael Comly, Investigator

Christopher W. Robinson, Investigator

Andrew David, Industry Analyst

Cindy Cohen, Economist

David Boyland, Accountant

Lita David-Harris, Statistician

Darlene Smith, Statistical Assistant

Karl von Schrittz, Attorney

Craig Thomsen, Supervisory Investigator

Address all communications to
Secretary to the Commission
United States International Trade Commission
Washington, DC 20436

U.S. International Trade Commission

Washington, DC 20436
www.usitc.gov

Large Power Transformers from Korea

Investigation No. 731-TA-1189 (Review)

Publication 4826



September 2018

CONTENTS

	Page
Determination	1
Views of the Commission	3
Part I: Introduction	I-1
Background.....	I-1
The original investigations.....	I-2
Related investigations	I-2
Summary data	I-2
Statutory criteria and organization of the report	I-5
Statutory criteria	I-5
Organization of report.....	I-7
Commerce’s reviews	I-7
Administrative reviews.....	I-7
Five-year review	I-8
The subject merchandise	I-9
Commerce’s scope	I-9
Tariff treatment.....	I-9
The product.....	I-10
Description and applications.....	I-10
Manufacturing processes	I-22
Domestic like product issues.....	I-24
U.S. market participants.....	I-25
U.S. producers	I-25
U.S. importers.....	I-26
U.S. purchasers.....	I-26
Apparent U.S. consumption and U.S. market shares.....	I-27

CONTENTS

	Page
Part II: Conditions of competition in the U.S. market.....	II-1
U.S. market characteristics.....	II-1
Channels of distribution	II-2
Geographic distribution	II-3
Supply and demand considerations	II-3
U.S. supply	II-3
U.S. demand	II-7
Substitutability issues.....	II-13
Lead times	II-13
Knowledge of country sources	II-13
Factors affecting purchasing decisions.....	II-14
Comparisons of domestic products, subject imports, and nonsubject imports	II-18
Comparison of U.S.-produced and imported LPTs	II-18
Elasticity estimates.....	II-21
U.S. supply elasticity	II-21
U.S. demand elasticity	II-22
Substitution elasticity	II-22
Part III: Condition of the U.S. industry	III-1
Overview	III-1
Changes experienced by the industry	III-2
Anticipated changes in operations.....	III-3
U.S. production, capacity, and capacity utilization.....	III-3
Constraints on capacity	III-5
U.S. producers' U.S. shipments and exports.....	III-5
U.S. producers' inventories.....	III-6
U.S. producers' imports.....	III-6
U.S. employment, wages, and productivity	III-6

CONTENTS

	Page
Part III: Condition of the U.S. industry--Continued	
Financial experience of U.S. producers.....	III-15
Background.....	III-15
Operations on LPTs.....	III-16
Capital expenditures and research and development expenses	III-20
Assets and return on assets.....	III-21
Part IV: U.S. imports and the foreign industries.....	IV-1
U.S. imports.....	IV-1
Overview.....	IV-1
Imports from subject and nonsubject countries.....	IV-1
U.S. importers' imports subsequent to March 31, 2018	IV-3
U.S. importers' inventories	IV-3
The industry in Korea	IV-3
Overview.....	IV-3
Changes in operations	IV-4
Operations on LPTs.....	IV-4
Alternative products.....	IV-7
Exports.....	IV-8
Antidumping or countervailing duty orders in third-country markets.....	IV-10
Global market.....	IV-11
Global market	IV-11
Global industry	IV-12

CONTENTS

	Page
Part V: Pricing data	V-1
Factors affecting prices	V-1
Raw material costs	V-1
Transportation costs to the U.S. market	V-2
U.S. inland transportation costs	V-2
Pricing practices	V-3
Pricing methods.....	V-3
Sales terms and discounts	V-3
Long-term supply agreements	V-3
Planned projects and renewal agreements	V-5
Price leadership	V-5
Bid process.....	V-6
Bid data	V-8
Purchasers' perceptions of relative price trends	V-9
Appendixes	
A. <i>Federal Register</i> notices.....	A-1
B. List of hearing witnesses.....	B-1
C. Summary data	C-1
D. Comments regarding the effects of the orders and the likely effects of revocation	D-1
E. Bid data	E-1

Note.—Information that would reveal confidential operations of individual concerns may not be published. Such information is identified by brackets or by parallel lines in confidential reports and is deleted and replaced with asterisks in public reports.

UNITED STATES INTERNATIONAL TRADE COMMISSION

Investigation No. 731-TA-1189 (Review)

Large Power Transformers from Korea

DETERMINATION

On the basis of the record¹ developed in the subject five-year review, the United States International Trade Commission (“Commission”) determines, pursuant to the Tariff Act of 1930 (“the Act”), that revocation of the antidumping duty order on large power transformers from Korea would be likely to lead to continuation or recurrence of material injury to an industry in the United States within a reasonably foreseeable time.

BACKGROUND

The Commission, pursuant to section 751(c) of the Act (19 U.S.C. 1675(c)), instituted this review on July 3, 2017 (82 F.R. 30896) and determined on October 6, 2017 that it would conduct a full review (82 F.R. 49229, October 24, 2017). Notice of the scheduling of the Commission’s review and of a public hearing to be held in connection therewith was given by posting copies of the notice in the Office of the Secretary, U.S. International Trade Commission, Washington, DC, and by publishing the notice in the *Federal Register* on April 10, 2018 (83 F.R. 15398). The hearing was held in Washington, DC, on July 26, 2018, and all persons who requested the opportunity were permitted to appear in person or by counsel.

¹ The record is defined in sec. 207.2(f) of the Commission’s Rules of Practice and Procedure (19 CFR 207.2(f)).

Views of the Commission

Based on the record in this five-year review, we determine under section 751(c) of the Tariff Act of 1930, as amended (“the Tariff Act”), that revocation of the antidumping duty order on large power transformers (“LPTs”) from Korea would be likely to lead to continuation or recurrence of material injury to an industry in the United States within a reasonably foreseeable time.

I. Background

On August 24, 2012, the Commission determined that an industry in the United States was materially injured by reason of imports of LPTs from Korea sold at less than fair value.¹ Commerce published the antidumping duty order on LPTs from Korea on August 31, 2012.²

The Commission instituted this first review of the antidumping duty order on LPTs from Korea on July 3, 2017.³ The Commission found the group responses of both the domestic interested parties and the respondent interested parties to be adequate, and therefore determined to conduct a full review.⁴

The Commission received joint prehearing and posthearing submissions and final comments from domestic producers ABB, Inc. (“ABB”), SPX Transformer Solutions, Inc. (“SPX”), Delta Star Inc. (“Delta Star”), Pennsylvania Transformer Technology, Inc. (“PTTI”), and Virginia Transformer Corp. and Caravels, LLC d/b/a Georgia Transformer Corp. (“VA Transformer”) (collectively, the “domestic interested parties”), which were also petitioners in the original investigation. The domestic interested parties also participated in the hearing accompanied by counsel. The Commission received prehearing and posthearing submissions and final comments from foreign producer Hyosung Heavy Industries Corporation and importer HICO America Sales and Technologies, Inc. (collectively, “Hyosung”) and from foreign producer and importer Hyundai Electric & Energy Systems (“Hyundai”), respectively. Hyundai and its counsel also participated in the hearing.

¹ *Large Power Transformers from Korea*, Inv. No. 731-TA-1189 (Final), USITC Pub. 4346 (August 2012) (“Original Determination”).

² *Large Power Transformers from the Republic of Korea: Antidumping Duty Order*, 77 Fed. Reg. 53177 (August 31, 2012).

³ *Large Power Transformers from Korea: Institution of a Five-Year Review*, 82 Fed. Reg. 30896 (July 3, 2017).

⁴ *Large Power Transformers from Korea: Notice of Commission Determination to Conduct a Full Five-Year Review*, 82 Fed. Reg. 49229 (October 24, 2017).

II. Domestic Like Product and Industry

A. Domestic Like Product

In making its determination under section 751(c) of the Tariff Act, the Commission defines the “domestic like product” and the “industry.”⁵ The Tariff Act defines “domestic like product” as “a product which is like, or in the absence of like, most similar in characteristics and uses with, the article subject to an investigation under this subtitle.”⁶ The Commission’s practice in five-year reviews is to examine the domestic like product definition from the original investigation and consider whether the record indicates any reason to revisit the prior findings.⁷

1. The Subject Merchandise

Commerce has defined the scope of the antidumping duty order in this five-year review as follows:

{L}arge liquid dielectric power transformers (LPTs) having a top power handling capacity greater than or equal to 60,000 kilovolt amperes (60 megavolt amperes), whether assembled or unassembled, complete or incomplete.

Incomplete LPTs are subassemblies consisting of the active part and any other parts attached to, imported with or invoiced with the active parts of LPTs. The “active part” of the transformer consists of one or more of the following when attached to or otherwise assembled with one another: The steel core or shell, the windings, electrical insulation between the windings, the mechanical frame for an LPT.

The product definition encompasses all such LPTs regardless of name designation, including but not limited to step-up transformers, step-down transformers, autotransformers, interconnection transformers, voltage regulator transformers, rectifier transformers, and power rectifier transformers.

⁵ 19 U.S.C. § 1677(4)(A).

⁶ 19 U.S.C. § 1677(10); *see, e.g., Cleo Inc. v. United States*, 501 F.3d 1291, 1299 (Fed. Cir. 2007); *NEC Corp. v. Department of Commerce*, 36 F. Supp. 2d 380, 383 (Ct. Int’l Trade 1998); *Nippon Steel Corp. v. United States*, 19 CIT 450, 455 (1995); *Timken Co. v. United States*, 913 F. Supp. 580, 584 (Ct. Int’l Trade 1996); *Torrington Co. v. United States*, 747 F. Supp. 744, 748-49 (Ct. Int’l Trade 1990), *aff’d*, 938 F.2d 1278 (Fed. Cir. 1991); *see also* S. Rep. No. 249, 96th Cong., 1st Sess. 90-91 (1979).

⁷ *See, e.g., Internal Combustion Industrial Forklift Trucks from Japan*, Inv. No. 731-TA-377 (Second Review), USITC Pub. 3831 at 8-9 (Dec. 2005); *Crawfish Tail Meat from China*, Inv. No. 731-TA-752 (Review), USITC Pub. 3614 at 4 (July 2003); *Steel Concrete Reinforcing Bar from Turkey*, Inv. No. 731-TA-745 (Review), USITC Pub. 3577 at 4 (Feb. 2003).

The LPTs subject to this order are currently classifiable under subheadings 8504.23.0040, 8504.23.0080 and 8504.90.9540 of the Harmonized Tariff Schedule of the United States (HTSUS). Although the HTSUS subheadings are provided for convenience and customs purposes, the written description of the scope of this order is dispositive.⁸

LPTs use electromagnetic induction between circuits to increase, decrease, or regulate power.⁹ Power, as measured in volt-amperes, is typically transmitted at a high voltage and low current (amperage) because transmission at higher amperages requires more cable, resulting in greater power losses, and is more expensive.¹⁰ For this reason, power is typically generated at less than 35 kilovolts (“kV”), increased for transmission to 69 to 765 kV (and the amps reduced), then decreased for distribution to 15 to 34.5 kV (and the amps increased).¹¹ LPTs are the equipment in the electric power grid that increase or decrease these voltages.¹² The users of LPTs include independent power producers; electric utilities, including investor-owned and public utilities; and industrial customers.¹³ LPTs are expensive pieces of capital equipment, typically costing millions of dollars, and are expected to last 15 to 40 years, although their targeted lifespan is around 30 years.¹⁴

The “active part” of an LPT, where the electromagnetic induction occurs, consists of the core, the windings, and electrical insulation between the windings.¹⁵ The core is made of very thin grain-oriented electrical steel (“GOES”) coated with a glass film.¹⁶ Around the core are wrapped thin strands of copper wire insulated with paper known as windings, forming the primary (input) and secondary (output) conductors.¹⁷ As alternating current enters the core through the primary conductor, it creates a fluctuating magnetic field that generates a higher or lower voltage in the secondary conductor, which then exits the transformer.¹⁸ The ratio of turns between the primary and secondary windings determines the output voltage, with more turns in the primary conductor than in the secondary conductor resulting in reduced voltage and more turns in the secondary conductor than in the primary conductor resulting in increased voltage.¹⁹ If taps are inserted into the winding, the output voltage of an LPT can be adjusted by

⁸ *Large Power Transformers From the Republic of Korea: Final Results of the Expedited First Sunset Review of the Antidumping Duty Order*, 82 Fed. Reg. 51604 (November 7, 2017).

⁹ Confidential Report (“CR”) at I-15; Public Report (“PR”) at I-11.

¹⁰ CR at I-22; PR at I-16.

¹¹ CR at I-22; PR at I-16. Voltage in the electrical transmission system is measured in kV. *Id.*

¹² CR at I-22; PR at I-16.

¹³ CR at I-25; PR at I-19.

¹⁴ CR at I-13; PR at I-10.

¹⁵ CR at I-15; PR at I-11.

¹⁶ CR at I-15; PR at I-11.

¹⁷ CR at I-16; PR at I-12; CR/PR at Figures I-3-4, 6.

¹⁸ CR at I-15, 22; PR at I-11, 16.

¹⁹ CR at I-16-17; PR at I-12.

changing between taps either manually or automatically by a motor, which changes the ratio of turns between the primary and secondary windings.²⁰

LPTs are produced as “single-phase” or “three-phase” models. A single-phase LPT has one set of primary and secondary windings wound around the core, while a three-phase LPT has three sets of primary and secondary windings wound around three core limbs.²¹ Because the voltage of alternating current rises and falls along a sine wave, single-phase LPTs have their output interrupted periodically.²² Three-phase LPTs provide continuous output because when the current stops in one phase of the transformer it continues to flow through the other two phases.²³ ***.²⁴

There are two typical configurations of the core and windings of LPTs: the shell form and the core form.²⁵ In shell form LPTs, the windings are wound around a central leg of the magnetic core in a rectangular configuration, and the core extends around the windings to enclose them.²⁶ Shell form LPTs use more GOES than other core types.²⁷ Because shell form LPTs are better able to withstand short circuits, purchasers prefer to use them in industrial applications prone to short circuiting, such as steel mills, and in very high voltage single-phase LPTs.²⁸ Core type LPTs feature circular shaped windings wound around one core limb per phase, which are not enclosed by the core and thus easier to service.²⁹

The active part of the transformer is placed inside of a metal tank filled with fluid, such as mineral oil, which dissipates heat generated by the transformer.³⁰ As the oil heats up, it circulates to a radiator, where it is cooled as the heat dissipates.³¹ Helping to cool the oil are fans and sometimes heat exchangers.³² As the oil expands, it may travel to a separate tank attached to a frame called an oil conservator.³³

LPTs are connected to transmission lines with accordion-like cylinders known as bushings, which also ***.³⁴ A single-phase transformer has four bushings, and a three-phase unit has six bushings.³⁵ Other parts present in LPTs include tap changers, power cable connectors, gas-operated relays (to detect certain types of problems and minimize subsequent

²⁰ CR at I-17; PR at I-12.

²¹ CR at I-18; PR at I-13.

²² CR at I-18; PR at I-13.

²³ CR at I-18; PR at I-13.

²⁴ CR at I-18; PR at I-13.

²⁵ CR at I-18; PR at I-13; CR/PR at Figure I-6.

²⁶ CR at I-18; PR at I-13; CR/PR at Figure I-6.

²⁷ CR at I-18; PR at I-13.

²⁸ CR at I-18; PR at I-13.

²⁹ CR at I-18; PR at I-13; CR/PR at Figure I-6.

³⁰ CR at I-19; PR at I-13.

³¹ CR at I-19; PR at I-13.

³² CR at I-19-20; PR at I-13.

³³ CR at I-20; PR at I-13.

³⁴ CR at I-20; PR at I-14; CR/PR at Figure I-4.

³⁵ CR at I-20; PR at I-14.

damage within the transformers), thermometers, pressure relief devices, dehydrating breathers, oil level indicators, and other controls.³⁶ LPTs also incorporate sensors, which monitor a range of operating conditions, and related monitoring and control equipment and software that record data, automatically control certain functions, allow for remote monitoring, and perform condition analysis.³⁷

The size of a LPT is determined by the load measured by megavolt-amperes (“MVAs”), the secondary output voltage, and the primary input voltage.³⁸ The MVA rating system is an industry standard and delineates the conditions under which the maximum load that a transformer can handle without overheating is measured.³⁹ Typically, customer requests for bids will specify the MVA for the transformer at 55 degrees Celsius and then one or two stages of forced cooling.⁴⁰ These ratings are displayed as three numbers, such as 115/153/192 MVA. The first rating is “oil natural, air natural,” with no additional cooling from fans, and the second and third ratings are with progressively more cooling added. LPTs are “top rated” at their highest MVA rating.⁴¹ Some LPTs that run at full capacity continuously have only a single MVA rating.⁴²

2. The Original Investigation

In the original investigation, petitioners urged the Commission to define a single domestic like product consisting of all LPTs within the scope of the investigation.⁴³ Respondents argued that the Commission should define two domestic like products corresponding to (1) 60-300 MVA top rated power transformers for 345 kV high line system voltage, plus 60 MVA or more top rated power transformers with high line voltage of less than 345kV (“Category A”) and (2) 60 MVA and above power transformers with a high line voltage of 500 kV or more plus LPTs above 300 MVA with a 345 kV high line voltage (“Category B”).⁴⁴

Based on an analysis of its traditional like product factors, the Commission rejected respondents’ arguments and defined a single domestic like product coextensive with the scope. The Commission found that all LPTs within the scope were similar in terms of their physical characteristics and uses, channels of distribution, and manufacturing facilities, production processes, and production employees.⁴⁵ Specifically, the Commission found that all LPTs used electromagnetic induction between circuits to increase, decrease, or regulate power, and all possessed similar physical characteristics, including an “active part” consisting of the core,

³⁶ CR at I-20; PR at I-14.

³⁷ CR at I-20; PR at I-14.

³⁸ CR at I-21; PR at I-15.

³⁹ CR at I-21; PR at I-15.

⁴⁰ CR at I-21; PR at I-15.

⁴¹ All references to MVA ratings are to top rated MVA ratings, unless otherwise noted.

⁴² CR at I-21; PR at I-15.

⁴³ Original Determination, USITC Pub. 4346 at 6.

⁴⁴ Original Determination, USITC Pub. 4346 at 6.

⁴⁵ Original Determination, USITC Pub. 4346 at 6-8.

windings, and insulation.⁴⁶ While recognizing that larger LPTs may be considered more “critical” than smaller LPTs in that their failure would affect more customers, the Commission found no clear dividing line separating the end uses of small and large LPTs because either type could be considered “critical” in other respects, and used in nuclear power generation.⁴⁷ The Commission further found that all LPTs within the scope were sold to independent power producers and electric utilities and that three domestic producers produced Category A and B LPTs in the same facilities using the same production processes and employees.⁴⁸

The Commission also found some differences between Category A and Category B LPTs, but concluded that they did not outweigh the similarities.⁴⁹ Although customer perceptions of LPTs in Categories A and B were mixed, the Commission found that most domestic producers perceived such LPTs to be similar, and that no industry standard or publication drew any distinction between LPTs in the two categories.⁵⁰ The Commission also found that a lack of interchangeability characterized the entire continuum of LPT products, not just LPTs in Categories A and B, given that LPTs built to different specifications are not interchangeable.⁵¹ Similarly, the Commission found that LPT prices varied by specification, as would be expected of a continuum of products.⁵²

Having found that the similarities between Category A and B LPTs outweighed their differences, the Commission defined a single domestic like product coextensive with the scope of the investigation.⁵³

3. The Current Review

In five-year reviews, the Commission frequently adopts the domestic like product definition from the original determination where the record does not suggest that any change is appropriate and no party has argued for a different definition. The domestic interested parties have argued, and respondent interested parties do not dispute, that the Commission should adopt the domestic like product definition from the original investigation.⁵⁴ There is no

⁴⁶ Original Determination, USITC Pub. 4346 at 6-7.

⁴⁷ Original Determination, USITC Pub. 4346 at 7.

⁴⁸ Original Determination, USITC Pub. 4346 at 8.

⁴⁹ Original Determination, USITC Pub. 4346 at 9.

⁵⁰ Original Determination, USITC Pub. 4346 at 8-9.

⁵¹ Original Determination, USITC Pub. 4346 at 8-9.

⁵² Original Determination, USITC Pub. 4346 at 8-9.

⁵³ Original Determination, USITC Pub. 4346 at 9.

⁵⁴ In its response to the notice of institution, Hyundai stated that it disagreed with the Commission’s definition of the domestic like product from the original investigation and that transformers above 765 kV should be treated as a separate domestic like product. Hyundai’s Response to the Notice of Institution, at 8. Yet, Hyundai did not request the collection of data concerning LPTs above 765 kV in its comments on the draft questionnaires, and did not contest the domestic like product definition from the original investigation in its briefs or hearing testimony during the review. See *generally*, Hyundai’s Comments on the Draft Questionnaires, Prehearing Brief, Posthearing Brief, and Final Comments. Similarly, Hyosung has not contested the domestic like product definition from the (Continued...)

new information in the record to indicate that the Commission should revisit the domestic like product definition from the original determination.⁵⁵ We therefore again define the domestic like product as all LPTs, coextensive with the scope of the order.

B. Domestic Industry

Section 771(4)(A) of the Tariff Act defines the relevant industry as the domestic “producers as a whole of a domestic like product, or those producers whose collective output of a domestic like product constitutes a major proportion of the total domestic production of the product.”⁵⁶ In defining the domestic industry, the Commission’s general practice has been to include in the industry producers of all domestic production of the like product, whether toll-produced, captively consumed, or sold in the domestic merchant market.

1. The Original Investigation

In the original investigation, the Commission defined the domestic industry as all domestic producers of LPTs.⁵⁷ There were no issues under the related parties provision of the statute.⁵⁸

2. The Current Review

In this review, domestic producer Hyundai Power Transformers USA, Inc. (“HYPO”) is a related party because it is related to ***, which is a Korean LPT producer and a U.S. importer of LPTs from Korea.⁵⁹ We must therefore determine whether HYPO should be excluded from the domestic industry pursuant to section 771(4)(B) of the Tariff Act. This provision allows the Commission, if appropriate circumstances exist, to exclude from the domestic industry producers that are related to an exporter or importer of subject merchandise or which are themselves importers.⁶⁰ Exclusion of such a producer is within the Commission’s discretion

(...Continued)

original investigation. See Hyosung’s Comments on the Draft Questionnaires, Prehearing Brief, Posthearing Brief, and Final Comments.

⁵⁵ See generally, CR at I-13-29; PR at I-10-22.

⁵⁶ 19 U.S.C. § 1677(4)(A). The definitions in 19 U.S.C. § 1677 are applicable to the entire subtitle containing the antidumping and countervailing duty laws, including 19 U.S.C. §§ 1675 and 1675a. See 19 U.S.C. § 1677.

⁵⁷ Original Determination, USITC Pub. 4346 at 9.

⁵⁸ Original Determination, USITC Pub. 4346 at 9 n.55.

⁵⁹ Hearing Tr. at 128-29 (Kang); CR at I-35; PR at I-25; CR/PR at Table I-6.

⁶⁰ See *Torrington Co. v. United States*, 790 F. Supp. 1161, 1168 (Ct. Int’l Trade 1992), *aff’d without opinion*, 991 F.2d 809 (Fed. Cir. 1993); *Sandvik AB v. United States*, 721 F. Supp. 1322, 1331-32 (Ct. Int’l Trade 1989), *aff’d mem.*, 904 F.2d 46 (Fed. Cir. 1990); *Empire Plow Co. v. United States*, 675 F. Supp. 1348, 1352 (Ct. Int’l Trade 1987).

based upon the facts presented in each investigation.⁶¹ We discuss below whether appropriate circumstances exist to exclude HYPO from the domestic industry.

a. Arguments of the Parties

The domestic interested parties argue that the Commission should define the domestic industry as all domestic producers of LPTs, including HYPO, without addressing the issue of related parties.⁶² The respondent interested parties have not addressed the issues of the appropriate domestic industry definition or the exclusion of any related party.

b. Analysis

HYPO opened its LPT production facility in Montgomery, Alabama in November 2011 and shipped its first transformer in January 2012.⁶³ HYPO's capacity increased from *** MVA in 2015 to *** MVA in 2017 and is projected to increase to 20,122 MVA in the first quarter of 2019 pursuant to a \$26.6 million investment in new capacity.⁶⁴ During the period of review, HYPO's production of LPTs increased *** from *** MVA in 2015 to *** MVA in 2017, and was *** MVA in January-March 2018 ("interim 2018") compared to *** MVA in January-March 2017 ("interim 2017").⁶⁵ In 2017, HYPO was the *** largest domestic producer, accounting for *** percent of domestic industry production that year.⁶⁶ HYPO *** during the period of review, ***.⁶⁷ The ratio of affiliate Hyundai's imports of LPTs from Korea to HYPO's domestic production of LPTs declined from *** percent in 2015 to *** percent in 2016 and *** percent in 2017; it was *** percent in interim 2017 and *** percent in interim 2018.⁶⁸ HYPO's

⁶¹ The primary factors the Commission has examined in deciding whether appropriate circumstances exist to exclude a related party include the following:

- (1) the percentage of domestic production attributable to the importing producer;
- (2) the reason the U.S. producer has decided to import the product subject to investigation (whether the firm benefits from the LTFV sales or subsidies or whether the firm must import in order to enable it to continue production and compete in the U.S. market);
- (3) whether inclusion or exclusion of the related party will skew the data for the rest of the industry;
- (4) the ratio of import shipments to U.S. production for the imported product; and
- (5) whether the primary interest of the importing producer lies in domestic production or importation. *Changzhou Trina Solar Energy Co. v. USITC*, 100 F. Supp. 3d 1314, 1326-31 (Ct. Int'l. Trade 2015); see also *Torrington Co. v. United States*, 790 F. Supp. at 1168.

⁶² Domestic Interested Parties' Prehearing Brief at 6.

⁶³ CR/PR at Table III-1.

⁶⁴ CR/PR at Tables III-3-4; Hyundai's Prehearing Brief at 19-20.

⁶⁵ CR/PR at Table III-4.

⁶⁶ CR/PR at Table I-5.

⁶⁷ CR/PR at Table III-10.

⁶⁸ CR/PR at Table III-4; Importers' Questionnaire Response of Hyundai at Question II-5a.

operating loss and net loss to net sales ratios were *** than the domestic industry average in 2017 and interim 2018.⁶⁹

The record of the review indicates that HYPO's primary interest is in domestic production of LPTs rather than importation. In particular, HYPO was the *** largest domestic producer of LPTs in 2017, increased its domestic production relative to its affiliate's subject imports during the period of review, and plans a significant expansion of its capacity. Although HYPO *** continuation of the order, no party has argued that HYPO should be excluded from the definition of the domestic industry.⁷⁰ Nor is there any evidence that HYPO has benefitted from its status as a related party.

For all of these reasons, we find that appropriate circumstances do not exist to exclude HYPO from the domestic industry as a related party. Based on our definition of the domestic like product, we define the domestic industry as all domestic producers of LPTs, including ABB, Delta Star, HYPO, Mitsubishi, PTTI, SPX, and VA Transformer.⁷¹

III. Revocation of the Antidumping Duty Order Would Likely Lead to Continuation or Recurrence of Material Injury Within a Reasonably Foreseeable Time

A. Legal Standards

In a five-year review conducted under section 751(c) of the Tariff Act, Commerce will revoke an antidumping or countervailing duty order unless: (1) it makes a determination that dumping or subsidization is likely to continue or recur and (2) the Commission makes a determination that revocation of the antidumping or countervailing duty order "would be likely to lead to continuation or recurrence of material injury within a reasonably foreseeable time."⁷² The SAA states that "under the likelihood standard, the Commission will engage in a counterfactual analysis; it must decide the likely impact in the reasonably foreseeable future of an important change in the status quo – the revocation or termination of a proceeding and the elimination of its restraining effects on volumes and prices of imports."⁷³ Thus, the likelihood standard is prospective in nature.⁷⁴ The U.S. Court of International Trade has found that

⁶⁹ CR/PR at Table III-14.

⁷⁰ CR/PR at Table I-4.

⁷¹ CR/PR at Table I-5.

⁷² 19 U.S.C. § 1675a(a).

⁷³ SAA at 883-84. The SAA states that "{t}he likelihood of injury standard applies regardless of the nature of the Commission's original determination (material injury, threat of material injury, or material retardation of an industry). Likewise, the standard applies to suspended investigations that were never completed." *Id.* at 883.

⁷⁴ While the SAA states that "a separate determination regarding current material injury is not necessary," it indicates that "the Commission may consider relevant factors such as current and likely continued depressed shipment levels and current and likely continued {sic} prices for the domestic like (Continued...)"

“likely,” as used in the five-year review provisions of the Act, means “probable,” and the Commission applies that standard in five-year reviews.⁷⁵

The statute states that “the Commission shall consider that the effects of revocation or termination may not be imminent, but may manifest themselves only over a longer period of time.”⁷⁶ According to the SAA, a “‘reasonably foreseeable time’ will vary from case-to-case, but normally will exceed the ‘imminent’ timeframe applicable in a threat of injury analysis in original investigations.”⁷⁷

Although the standard in a five-year review is not the same as the standard applied in an original investigation, it contains some of the same fundamental elements. The statute provides that the Commission is to “consider the likely volume, price effect, and impact of imports of the subject merchandise on the industry if the orders are revoked or the suspended investigation is terminated.”⁷⁸ It directs the Commission to take into account its prior injury determination, whether any improvement in the state of the industry is related to the order or the suspension agreement under review, whether the industry is vulnerable to material injury if an order is revoked or a suspension agreement is terminated, and any findings by Commerce regarding duty absorption pursuant to 19 U.S.C. § 1675(a)(4).⁷⁹ The statute further provides that the presence or absence of any factor that the Commission is required to consider shall not necessarily give decisive guidance with respect to the Commission’s determination.⁸⁰

In evaluating the likely volume of imports of subject merchandise if an order under review is revoked and/or a suspended investigation is terminated, the Commission is directed

(...Continued)

product in the U.S. market in making its determination of the likelihood of continuation or recurrence of material injury if the order is revoked.” SAA at 884.

⁷⁵ See *NMB Singapore Ltd. v. United States*, 288 F. Supp. 2d 1306, 1352 (Ct. Int’l Trade 2003) (“‘likely’ means probable within the context of 19 U.S.C. § 1675(c) and 19 U.S.C. § 1675a(a)”), *aff’d mem.*, 140 Fed. Appx. 268 (Fed. Cir. 2005); *Nippon Steel Corp. v. United States*, 26 CIT 1416, 1419 (2002) (same); *Usinor Industeel, S.A. v. United States*, 26 CIT 1402, 1404 nn.3, 6 (2002) (“more likely than not” standard is “consistent with the court’s opinion;” “the court has not interpreted ‘likely’ to imply any particular degree of ‘certainty’”); *Indorama Chemicals (Thailand) Ltd. v. United States*, 26 CIT 1059, 1070 (2002) (“standard is based on a likelihood of continuation or recurrence of injury, not a certainty”); *Usinor v. United States*, 26 CIT 767, 794 (2002) (“‘likely’ is tantamount to ‘probable,’ not merely ‘possible’”).

⁷⁶ 19 U.S.C. § 1675a(a)(5).

⁷⁷ SAA at 887. Among the factors that the Commission should consider in this regard are “the fungibility or differentiation within the product in question, the level of substitutability between the imported and domestic products, the channels of distribution used, the methods of contracting (such as spot sales or long-term contracts), and lead times for delivery of goods, as well as other factors that may only manifest themselves in the longer term, such as planned investment and the shifting of production facilities.” *Id.*

⁷⁸ 19 U.S.C. § 1675a(a)(1).

⁷⁹ 19 U.S.C. § 1675a(a)(1). Commerce has made no duty absorption findings. CR at I-10 n.11; PR at I-7 n.11.

⁸⁰ 19 U.S.C. § 1675a(a)(5). Although the Commission must consider all factors, no one factor is necessarily dispositive. SAA at 886.

to consider whether the likely volume of imports would be significant either in absolute terms or relative to production or consumption in the United States.⁸¹ In doing so, the Commission must consider “all relevant economic factors,” including four enumerated factors: (1) any likely increase in production capacity or existing unused production capacity in the exporting country; (2) existing inventories of the subject merchandise, or likely increases in inventories; (3) the existence of barriers to the importation of the subject merchandise into countries other than the United States; and (4) the potential for product shifting if production facilities in the foreign country, which can be used to produce the subject merchandise, are currently being used to produce other products.⁸²

In evaluating the likely price effects of subject imports if an order under review is revoked and/or a suspended investigation is terminated, the Commission is directed to consider whether there is likely to be significant underselling by the subject imports as compared to the domestic like product and whether the subject imports are likely to enter the United States at prices that otherwise would have a significant depressing or suppressing effect on the price of the domestic like product.⁸³

In evaluating the likely impact of imports of subject merchandise if an order under review is revoked and/or a suspended investigation is terminated, the Commission is directed to consider all relevant economic factors that are likely to have a bearing on the state of the industry in the United States, including but not limited to the following: (1) likely declines in output, sales, market share, profits, productivity, return on investments, and utilization of capacity; (2) likely negative effects on cash flow, inventories, employment, wages, growth, ability to raise capital, and investment; and (3) likely negative effects on the existing development and production efforts of the industry, including efforts to develop a derivative or more advanced version of the domestic like product.⁸⁴ All relevant economic factors are to be considered within the context of the business cycle and the conditions of competition that are distinctive to the industry. As instructed by the statute, we have considered the extent to which any improvement in the state of the domestic industry is related to the orders under review and whether the industry is vulnerable to material injury upon revocation.⁸⁵

⁸¹ 19 U.S.C. § 1675a(a)(2).

⁸² 19 U.S.C. § 1675a(a)(2)(A-D).

⁸³ See 19 U.S.C. § 1675a(a)(3). The SAA states that “[c]onsistent with its practice in investigations, in considering the likely price effects of imports in the event of revocation and termination, the Commission may rely on circumstantial, as well as direct, evidence of the adverse effects of unfairly traded imports on domestic prices.” SAA at 886.

⁸⁴ 19 U.S.C. § 1675a(a)(4).

⁸⁵ The SAA states that in assessing whether the domestic industry is vulnerable to injury if the order is revoked, the Commission “considers, in addition to imports, other factors that may be contributing to overall injury. While these factors, in some cases, may account for the injury to the domestic industry, they may also demonstrate that an industry is facing difficulties from a variety of sources and is vulnerable to dumped or subsidized imports.” SAA at 885.

B. Conditions of Competition and the Business Cycle

In evaluating the likely impact of the subject imports on the domestic industry if an order is revoked, the statute directs the Commission to consider all relevant economic factors “within the context of the business cycle and conditions of competition that are distinctive to the affected industry.”⁸⁶

1. The Original Investigation

In the original investigation, the Commission addressed several conditions of competition relevant to its analysis. In terms of demand, the Commission found that overall U.S. demand for LPTs varied with the general economic cycle of the United States, driven by demand for electric power, industrial construction and housing starts, and federal incentives for renewable energy sources.⁸⁷ During the 2009 to 2011 period, apparent U.S. consumption of LPTs increased irregularly, with no clear demand trend.⁸⁸

In terms of supply, the Commission further found that the U.S. market was supplied by six domestic producers, subject imports, and nonsubject imports.⁸⁹ Of these sources, subject imports were the largest source of LPTs in 2010 and interim 2011, nonsubject imports were the largest source in 2009, 2011, and interim 2012, and domestic producers were the smallest source throughout the period of investigation.⁹⁰ In November 2011, HYPO, a wholly owned subsidiary of Hyundai Heavy Industries Co., Ltd., a Korean producer, opened a \$108 million LPT production facility in Montgomery, Alabama.⁹¹

In terms of substitutability, the Commission found that domestic and subject imported LPTs meeting the same specifications were highly substitutable, with each LPT built to order.⁹² In purchasing LPTs, the Commission explained, purchasers generally requested highly detailed quotes from prequalified or certified suppliers, and generally provided such suppliers with one opportunity to bid on a particular contract.⁹³ Purchasers assessed quotes based on both the initial cost and the total evaluated cost, comprised of the initial cost plus losses, of the LPTs.⁹⁴ Price was an important factor in purchasing decisions, but non-price factors such as meeting specifications and quality were important as well.⁹⁵

Several other conditions of competition informed the Commission’s analysis. The Commission found that lead times averaged eight to 11 months for domestic producers and

⁸⁶ 19 U.S.C. § 1675a(a)(4).

⁸⁷ Original Determination, USITC Pub. 4346 at 13.

⁸⁸ Original Determination, USITC Pub. 4346 at 13.

⁸⁹ Original Determination, USITC Pub. 4346 at 14.

⁹⁰ Original Determination, USITC Pub. 4346 at 14.

⁹¹ Original Determination, USITC Pub. 4346 at 14.

⁹² Original Determination, USITC Pub. 4346 at 14.

⁹³ Original Determination, USITC Pub. 4346 at 15.

⁹⁴ Original Determination, USITC Pub. 4346 at 15.

⁹⁵ Original Determination, USITC Pub. 4346 at 15.

nine to 14 months for importers.⁹⁶ Due to these long lead times and the custom-made nature of LPTs, inventories consisted of finished units in transit, rather than volume available for future sale.⁹⁷ Finally, the Commission observed that large investor-owned utilities established long-term (two to five year) alliances with particular suppliers using blanket agreements, alliance agreements, framework agreements, or memoranda of understanding.⁹⁸ While not guaranteeing sales, such agreements increased a supplier's likelihood of winning bids from a utility, while helping the utility acquire additional units of the LPTs subject to the agreement more rapidly. Sales pursuant to alliance agreements reportedly accounted for a "significant" percentage of LPT sales.⁹⁹

2. The Current Review

The following conditions of competition inform our determination.

a. Demand Conditions

LPT purchasers include independent power producers, electric utilities (categorized as investor-owned utilities, publicly owned utilities, cooperative electric utilities, and federal electric utilities), and industrial customers.¹⁰⁰ LPT demand is driven by the need to replace aging infrastructure and by the construction of new power generation facilities and transmission lines.¹⁰¹ Additions to new utility-scale power plants fluctuated during the period of review, declining overall from 28.8 gigawatts ("GW") in 2012 to 20.1 GW in 2017, and primarily consisted of new solar, wind, and natural gas generation capacity.¹⁰² Wind and solar power generating facilities are reportedly purchasing 90 to 100 MVA LPTs rather than the 200 to 500 MVA LPTs typically purchased by coal plants.¹⁰³ Investment by investor-owned utilities in power transmission increased steadily during the period from \$14.8 billion in 2013 to \$22.9 billion in 2017.¹⁰⁴ LPT demand is also influenced by U.S. electricity demand, industrial construction, and housing starts.¹⁰⁵ During the period of review, electricity generation was flat

⁹⁶ Original Determination, USITC Pub. 4346 at 15.

⁹⁷ Original Determination, USITC Pub. 4346 at 15.

⁹⁸ Original Determination, USITC Pub. 4346 at 16.

⁹⁹ Original Determination, USITC Pub. 4346 at 16.

¹⁰⁰ CR at I-25; PR at I-19. In 2016, electric utilities accounted for 56 percent of existing generator nameplate capacity, independent power producers accounted for 41 percent, and commercial and industrial users accounted for 3 percent. CR/PR at Figure I-10.

¹⁰¹ CR at II-13; PR at II-8.

¹⁰² CR at II-13; PR at II-8; CR/PR at Figure II-2.

¹⁰³ CR at II-19 n.18; PR at II-13 n.18.

¹⁰⁴ CR/PR at Figure II-3.

¹⁰⁵ CR at II-11-12; PR at II-7.

at around 4,000 million megawatt-hours per year, but housing starts increased in each year of the period.¹⁰⁶

Influenced by all of these factors, apparent U.S. consumption of LPTs was higher in 2017 than in 2012 but relatively flat during the 2015-17 period.¹⁰⁷ Specifically, apparent U.S. consumption increased from *** MVA in 2012 to *** MVA in 2013, *** MVA in 2014, *** MVA in 2015, and *** MA in 2016, before dipping to *** MVA in 2017, a level *** percent higher than in 2012 but *** percent lower than in 2015.¹⁰⁸ Apparent U.S. consumption was 32,267 MVA in interim 2017 and 41,250 MVA in interim 2018.¹⁰⁹

Responding domestic producers, importers, and purchasers disagree on anticipated future demand for LPTs in the United States. Most responding domestic producers (*** of ***) anticipate no change in LPT demand.¹¹⁰ By contrast, most responding importers (*** of ***) anticipate increased demand for LPTs.¹¹¹ Most responding purchasers anticipate either increased demand (9 of 20) or fluctuating demand (7 of 20) for LPTs.¹¹² In a February 2018 report, the U.S. Energy Information Administration projected that from 2017 to 2050, electricity demand will “rise slowly” at an average annual rate of 0.9 percent, while electricity delivered to residential and commercial buildings will experience “modest” growth at an average annual rate of 0.3 percent.¹¹³ Another factor that will potentially restrain LPT demand growth is the increasing use of monitoring technology on LPTs, which can extend the useful life of LPTs by permitting utilities to replace them when necessary instead of at an arbitrary age.¹¹⁴

b. Supply Conditions

Nonsubject imports supplied the largest share of apparent U.S. consumption in 2017, at *** percent, followed by the domestic industry, at *** percent, and subject imports, at *** percent.¹¹⁵

As in the original investigation, the domestic industry currently consists of seven producers, although there were notable changes to the composition of the industry during the

¹⁰⁶ CR at II-12; PR at II-7-8; CR/PR at Figure II-1.

¹⁰⁷ CR/PR at Table I-2.

¹⁰⁸ CR/PR at Tables I-2, C-1.

¹⁰⁹ CR/PR at Table I-9.

¹¹⁰ CR/PR at Table II-4.

¹¹¹ CR/PR at Table II-4.

¹¹² CR/PR at Table II-4.

¹¹³ U.S. Energy Information Administration, Annual Energy Outlook 2018 with projections to 2050, February 6, 2018, appended as Exhibit 4 to Hyundai’s Prehearing Brief, at 80, 122.

¹¹⁴ Hearing Tr. at 64 (Newman), 64 (Mason); Domestic Interested Parties’ Responses to Commissioner Questions at 47-48. On the other hand, Hyosung has not seen evidence that monitoring equipment itself extends the life of the transformer in such a way that demand has decreased. Hyosung’s Responses to Commissioner Questions at 2.

¹¹⁵ CR/PR at Table I-2.

period of review.¹¹⁶ In particular, Hyundai Power Transformers USA, Inc. (“HYPO”) opened an LPT production facility in Montgomery, Alabama in November 2011 and shipped its first LPT from the plant in January 2012.¹¹⁷ Mitsubishi opened an LPT production facility in Memphis, Tennessee, in April 2013 for the production of shell form transformers ranging from 300 to over 1,000 MVA.¹¹⁸ Caravels/Georgia Transformer Corp. purchased the Efacec LPT production facility in Georgia in December 2014 and formed a strategic partnership with VA Transformer in January 2015.¹¹⁹ ABB announced the closure of its LPT production facility in St. Louis, Missouri in November 2017 and ceased production there in July 2018, with plans to shift 70 percent of the production capability of LPTs previously handled by the St. Louis facility to a production facility in South Boston, Virginia.¹²⁰

Subject imports were supplied primarily by Hyundai and Hyosung, which together accounted for *** percent of reported Korean exports to the United States in 2017, and to a lesser extent by Iljin Electric Co., Ltd. (“Iljin”), which accounted for *** percent of such exports.¹²¹ Korea was the largest single country source of U.S. imports of LPTs in 2017 at *** percent of total imports, and the world’s second largest exporter of power transformers over 10 MVA during the 2015-17 period.¹²²

Major sources of nonsubject imports, in descending order of 2017 import volume, included Mexico, Austria, the Netherlands, Spain, and Germany.¹²³ Domestic producer ABB imported *** percent to *** percent of nonsubject imports during the 2015-17 period but only *** percent of such imports in interim 2018, compared to *** percent in interim 2017.¹²⁴

c. Substitutability and Other Conditions

We find a high degree of substitutability between subject imports and domestically produced LPTs of the same specifications.¹²⁵ Although each LPT is built to order based on a purchaser’s specifications, domestic producers and importers of LPTs from Korea compete for sales to a purchaser by submitting bids for the production of LPTs built to the same specifications.¹²⁶ All responding domestic producers and most responding purchasers reported that subject imports and domestically produced LPTs are always or frequently interchangeable, although most responding importers reported that subject imports and domestically produced

¹¹⁶ CR/PR at Table I-5.

¹¹⁷ CR/PR at Table III-1.

¹¹⁸ CR/PR at Table III-1.

¹¹⁹ CR/PR at Table III-1.

¹²⁰ CR/PR at Tables III-1-2; Declaration of Steve Robinson, appended as Exhibit 4 to Domestic Interested Parties’ Posthearing Brief, at paras. 3-4.

¹²¹ CR/PR at Table IV-6

¹²² CR/PR at Tables IV-1-2.

¹²³ CR/PR at Table IV-2.

¹²⁴ Compare CR/PR at Table III-10 to *id.* at Table IV-1.

¹²⁵ CR at II-19; PR at II-13; CR/PR at Tables II-10-13.

¹²⁶ CR at I-28, II-1, V-1; PR at I-22, II-1, V-1.

LPTs are only sometimes interchangeable.¹²⁷ When asked to compare subject imports to domestically produced LPTs according to 24 attributes relevant to their purchasing decisions, most responding purchasers reported that LPTs from the two sources are comparable with respect to all 24, including product consistency (16 of 18), product range (14 of 18), quality meets industry standards (16 of 18), quality exceeds industry standards (16 of 18), and technical support/service (15 of 18).¹²⁸ Similarly, most responding purchasers reported that subject imports and domestically produced LPTs are always or usually able to meet minimum quality specifications, with a similar proportion of responding purchasers reporting always for both subject imports (33.3 percent) and domestically produced LPTs (34.8 percent).¹²⁹ Most purchasers (17 of 25) reported that there were not certain types, capacities, or sizes of LPTs that were only available from specific country sources.¹³⁰ Responding domestic producers reported the ability to produce, and actual production of, the full range of LPTs in terms of both top rated MVA and kV.¹³¹

We also find that price is an important factor in purchasing decisions, although non-price factors are also important. When asked to rank the three most important factors influencing their purchasing decisions, more responding purchasers included quality (18), price (16), and lead time/delivery (11) among their top three factors than any other factors, with price mentioned more than any other factor as the second most important consideration.¹³² Similarly, when asked to rate the importance of 24 factors to their LPT purchasing decisions, 21 responding purchasers rated price as very important.¹³³ Eleven of 25 responding purchasers reported that they usually purchase the lowest-priced LPTs, ten reported sometimes, three reported never, and one reported always.¹³⁴ When asked how often differences other than price were significant in choosing between LPTs from Korea and the United States, most responding producers and purchasers reported sometimes or never, while most responding importers reported always or frequently.¹³⁵ Non-price factors that were rated very important by most responding purchasers included whether quality meets industry standards, delivery time, reliability of supply, technical support/service, and warranties.¹³⁶

¹²⁷ CR/PR at Table II-11.

¹²⁸ CR/PR at Table II-10.

¹²⁹ CR/PR at Table II-12.

¹³⁰ CR at II-22; PR at II-15.

¹³¹ CR/PR at Table III-6. Between *** and *** domestic producers reported the ability to produce, and actual production of, LPTs with a top rated range of 300 to 700 or greater MVA. *Id.*

¹³² CR/PR at Table II-6.

¹³³ CR/PR at Table II-7.

¹³⁴ CR at II-21; PR at II-14.

¹³⁵ CR/PR at Table II-13.

¹³⁶ CR/PR at Table II-7. Fifteen responding purchasers rated time to fill order as a very important consideration in their LPT purchasing decisions. *Id.* Most responding purchasers (13 of 18) reported that subject imports and domestically produced LPTs were comparable in terms of this factor. *Id.* at Table II-10. Responding domestic producers reported lead times ranging from 160 to 490 days and (Continued...)

The importance of price to purchasers is also reflected in the fact that LPTs are purchased pursuant to a bidding process, in which purchasers generally consider the total evaluated cost (the base price plus the ownership costs, including losses, over the expected life of a transformer) and sometimes the initial cost (including delivery and installation) of competing bids.¹³⁷ When requesting quotes from competing suppliers, purchasers detail the precise specifications of the required LPTs, including the desired physical characteristics, power ratings, line voltages, and other characteristics.¹³⁸ To assemble a formal bid, LPT suppliers must invest substantial time and money reviewing the specifications, designing the required LPT, and costing out the elements of the design.¹³⁹ In most cases, suppliers have only one opportunity to bid on a particular contract.¹⁴⁰

Most purchasers require suppliers to become certified or qualified before they can bid on projects, and the certification process may include the approval of a qualified design and an examination of a supplier's quality, reliability, engineering qualifications, and facility capabilities.¹⁴¹ The length of time necessary to qualify a new supplier varied among responding purchasers, with six reporting 90 days or fewer, seven reporting up to one year, and three reporting over one year.¹⁴² Eleven of the 12 responding purchasers reporting qualified Korean suppliers also reported qualified domestic suppliers, with eight of these eleven responding purchasers reporting at least one domestic supplier qualified to supply the same MVA and kV range as the qualified Korean supplier.¹⁴³

A majority of responding purchasers (13 of 25) reported purchasing at least some LPTs under long-term agreements, known variously as alliance agreements, blanket agreements, blanket contracts, master service agreements, or outline agreements.¹⁴⁴ Such agreements allow utilities to purchase LPTs of a similar design more rapidly and at lower cost while permitting suppliers to either lock in long term business or bid against a smaller number of

(...Continued)

averaging 323 days. CR at II-19; PR at II-13. Responding importers reported lead times ranging from 148 to 434 days and averaging 300 days. *Id.*

¹³⁷ CR at V-8; PR at V-5; Hearing Tr. at 93-94 (Mason).

¹³⁸ CR/PR at II-1; Hearing Tr. at 107 (Blake) (stating that a purchaser's "specifications could be 2- or 300 pages long of very detailed information.").

¹³⁹ CR/PR at II-1; Hearing Tr. at 106-07 (Blake) ("The utilities require almost a full design on the power transformer before you bid"), 108-09 (Mason) ("it is several weeks to do a single bid . . . On average, we build 1.2 units for each design that we do. So virtually every one of them is, every aspect from the tank sizing to the core sizing, to all of the cut pieces of material that go into the unit are designed specifically for that instance. So it's quite cumbersome.").

¹⁴⁰ CR at V-11; PR at V-6.

¹⁴¹ CR at II-23-24; PR at II-15 (21 of 25 responding purchasers require suppliers to be certified or qualified). Many publicly owned utilities, which accounted for 18 percent of utility generator nameplate capacity in 2013, do not require bidders to be prequalified. Hearing Tr. at 86-87 (Mason), 136 (Kang); CR/PR at Figure I-11.

¹⁴² CR at II-23-24; PR at II-15.

¹⁴³ CR at II-24-25; PR at II-16.

¹⁴⁴ CR at V-5; PR at V-4.

competitors.¹⁴⁵ Most long-term supply agreements reported by responding purchasers are not exclusive and therefore permit competition between suppliers for sales pursuant to the agreements.¹⁴⁶ Despite the prevalence of long-term supply agreements, both domestic and respondent interested parties report that a majority of LPT sales are made pursuant to bidding for projects rather than through alliance agreements.¹⁴⁷

We also find that there is some transparency with respect to competing bid prices and the identity of competitors in bidding events, although most responding purchasers reported that they do not quote competing prices during negotiations.¹⁴⁸ Suppliers can surmise the identity of their competitors for a project based on the companies that are qualified to submit bids or who possess alliance agreements with the utility seeking bids.¹⁴⁹ Most responding purchasers reported that they had attended post-bid meetings with suppliers that lost a bid and provided general feedback regarding whether the supplier was price-competitive, without revealing specific pricing.¹⁵⁰ Responding purchasers reported conveying general pricing information to suppliers through pricing guidance at a high level, feedback requested by customers, unsuccessful offer letters, win and loss rates, generalized discussions with unsuccessful bidders, and rankings of suppliers.¹⁵¹ Based on such feedback, a supplier can gain some understanding of how much higher their losing bid price was above the winning bid.¹⁵² Suppliers can also glean information on their competitors' pricing from the open bidding events held by public utilities, in which competitors and their bid prices are disclosed.¹⁵³

¹⁴⁵ CR at V-5-7; PR at V-3-4.

¹⁴⁶ CR at V-7; PR at V-4; CR/PR at Table V-2; *see also* Hearing Tr. at 111-12 (Mason), 112-13 (Blake), 186 (Kang).

¹⁴⁷ Domestic Interested Parties' Responses to Commissioner Questions at 19-20; Hyundai's Responses to Commissioner Questions at 1. Sales pursuant to alliance agreements as a share of total sales were *** percent for Delta Star, *** percent for ABB, *** percent for SPX over the past 18 months, *** percent for PTTI, and *** percent for Virginia Transformer. Domestic Interested Parties' Responses to Commissioner Questions at 19, Exhibits 4, 5, 11, 12, and 16. Hyundai claims that alliance agreements are used solely by *** and account for only *** to *** percent of LPT sales. Hyundai's Responses to Commissioner Questions at 1.

¹⁴⁸ CR at V-12; PR at V-7. The domestic interested parties also claim that domestic producers can be discouraged from even bidding on a potential sale by the likelihood of losing the bid to low-priced subject imports. Domestic Interested Parties' Prehearing Brief at 19. Noting the substantial amount of time and expense required to prepare a bid, the domestic interested parties claim that domestic producers may forego bids when past experience suggests they are likely to lose to subject imports in order to conserve their limited resources for preparing such bids. Domestic Interested Parties' Prehearing Brief at 20-23. During the period of review, ***. Domestic Interested Parties' Responses to Commissioner Questions at 16, Exhibits 8, 12, and 16.

¹⁴⁹ Hearing Tr. at 19 (Robinson), 81-82 (Mason).

¹⁵⁰ CR at V-12-13; PR at V-7.

¹⁵¹ CR at V-13-14; PR at V-7-8.

¹⁵² Hearing Tr. at 19 (Robinson), 23, 25 (Mason), 28 (Newman), 32 (Blake), 82-83 (Newman), 136-37, 167 (Kang).

¹⁵³ Hearing Tr. at 19 (Robinson), 167 (Kang), 185 (Campbell).

The major components and raw materials used to produce LPTs include windings, controls and accessories, and grain-oriented electrical steel (“GOES”).¹⁵⁴ Other inputs include steel plate and dielectric mineral oil.¹⁵⁵ Six of seven responding domestic producers reported that raw material prices either fluctuated or increased during the period of review and anticipate that raw material prices will increase in the reasonably foreseeable future.¹⁵⁶ Most responding domestic producers also reported that the imposition of tariffs on imports of steel products pursuant to section 232 has had or will have a substantial effect on their raw material prices.¹⁵⁷

C. Likely Volume of Subject Imports

1. The Original Investigation

In the original investigation, the Commission found subject import volume and the increase in that volume to be significant, both in absolute terms and relative to production and consumption in the United States.¹⁵⁸ Subject import volume increased *** percent between 2009 and 2011, but was lower in interim 2012, at *** MVA, than in interim 2011, at *** MVA.¹⁵⁹ Subject import market share increased irregularly from *** percent in 2009 to *** percent in 2011, and was *** percent in interim 2012 compared to *** percent in interim 2011.¹⁶⁰ Subject imports as a share of domestic production increased irregularly from *** percent in 2009 to *** percent in 2011, and were *** percent in interim 2012 compared to *** percent in interim 2011.¹⁶¹

The Commission recognized that the increase in subject imports coincided with rising apparent U.S. consumption and increasing domestic industry sales and shipments between 2009 and 2011.¹⁶² As subject imports captured 1.5 percentage points of market share from the domestic industry, however, the industry’s sales and shipments increased by considerably less than the increase in apparent U.S. consumption, though domestic producers had the capacity to supply the additional demand during the period.¹⁶³ Furthermore, the Commission found that

¹⁵⁴ CR/PR at V-1.

¹⁵⁵ CR/PR at V-1.

¹⁵⁶ CR/PR at V-1.

¹⁵⁷ CR at V-1-2; PR at V-1; CR/PR at Table V-1.

¹⁵⁸ Original Determination, USITC Pub. 4346 at 16.

¹⁵⁹ Confidential Views, *Large Power Transformers from Korea*, Inv. No. 731-TA-1189 (Final) (“Confidential Original Determination”), EDIS Doc. No. 620531, at 23-24.

¹⁶⁰ Confidential Original Determination at 24.

¹⁶¹ Confidential Original Determination at 24.

¹⁶² Original Determination, USITC Pub. 4346 at 17.

¹⁶³ Original Determination, USITC Pub. 4346 at 17. Subject imports also captured *** percentage points of market share from nonsubject imports. Confidential Original Determination at 24.

subject imports increased their market penetration with respect to product types for which competition between subject import and domestic producers was most intense.¹⁶⁴

2. The Current Review

We find that revocation of the order would likely result in a significant increase in subject import volume within a reasonably foreseeable time. We base this finding on the significant and increasing presence of subject imports in the U.S. market during the period of review, the significant capacity and unused capacity possessed by Korean producers, and the significant export orientation of the Korean producers, among other factors.

Subject imports maintained a significant and increasing presence in the U.S. market during the period of review, although subject import volume and market share remained lower with the order in place than during the period of investigation. After imposition of the order in 2011, subject import volume declined from *** MVA in 2012 to *** MVA in 2013 before increasing to *** MVA in 2014, *** MVA in 2015, *** MVA in 2016, and then declining to *** MVA in 2017.¹⁶⁵ Subject import volume was *** MVA in interim 2018, compared to *** MVA in interim 2017.¹⁶⁶ Subject imports as a share of apparent U.S. consumption exhibited a similar trend, declining initially from *** percent in 2012 to *** percent in 2013 before increasing to *** percent in 2014, *** percent in 2015, *** percent in 2016, and then declining to *** percent in 2017.¹⁶⁷ Subject imports as a share of apparent U.S. consumption were *** percent in interim 2018, compared to *** percent in interim 2017.¹⁶⁸ Given their substantial presence in the U.S. market, Korean producers possess the market knowledge and customer contacts necessary to rapidly increase their sales after revocation. Indeed, Korean producers were

¹⁶⁴ Original Determination, USITC Pub. 4346 at 17.

¹⁶⁵ CR/PR at Table I-1-2, 9.

¹⁶⁶ CR/PR at Table I-9. Lower subject import volume in interim 2018 compared to interim 2017 largely resulted from lower imports by Hyundai in interim 2018 (*** MVA) compared to interim 2017 (*** MVA). See Importers' Questionnaire of Hyundai at Question II-5a; compare Importers' Questionnaire of Hyosung at Question II-5a (reporting imports of *** MVA in interim 2017 and *** MVA in interim 2018). In the third antidumping duty administrative review, Commerce increased the cash deposit rate applicable to imports from Hyundai from 4.07 percent to 60.81 percent but lowered the cash deposit rate applicable to imports from Hyosung from 7.89 percent to 2.99 percent, as of March 13, 2017. *Large Power Transformers from the Republic of Korea: Final Results of Antidumping Duty Administrative Review*, 82 Fed. Reg. 13432 (March 13, 2017); CR/PR at Table I-3. Given importer lead times averaging 300 days, CR at II-19; PR at II-13, the higher cash deposit rate applicable to imports from Hyundai would have influenced its sales for delivery in interim 2018, even if Hyundai was able to enter LPTs under the 22 percent all others rate as alleged by the domestic interested parties. See Domestic Interested Parties' Prehearing Brief at 31-34; Domestic Interested Parties' Posthearing Brief at 5-6; Domestic Interested Parties' Responses to Commissioner Questions at 38-40.

¹⁶⁷ CR/PR at Table I-1-2, 9.

¹⁶⁸ CR/PR at Table I-9.

either qualified to sell or sold LPTs to 14 of 24 responding purchasers, which account for *** percent of reported LPT units open to bidding through 2019.¹⁶⁹

Korean producers also have substantial excess capacity which gives them the ability to increase their exports to the United States significantly after revocation. During the 2015-17 period, while responding Korean producers reported a 3.7 percent decline in their capacity, from 177,503 MVA in 2015 to 172,690 MVA in 2016 and 170,815 MVA in 2017, their production declined 12.6 percent, from 139,896 MVA in 2015 to 130,397 MVA in 2016 and 122,273 MVA in 2017.¹⁷⁰ Consequently, responding Korean producers reported a decline in their capacity utilization rate from 78.8 percent in 2015 to 75.5 percent in 2016 and 71.6 percent in 2017.¹⁷¹ The Korean producers' excess capacity in 2017 (48,542 MVA) was equivalent to 30.0 percent of apparent U.S. consumption that year.¹⁷² The Korean's industry's excess capacity in interim 2018 (23,420 MVA) was equivalent to an even greater percentage of apparent U.S. consumption, 56.8 percent.¹⁷³ The substantial excess capacity possessed by Korean producers at the end of the period of review would enable them to increase their exports to the United States significantly in the event of revocation.¹⁷⁴

Korean producers also have the incentive to fill their unused capacity with increased exports to the United States after revocation. Responding Korean producers were highly export oriented during the period of review, with exports as a share of their total shipments increasing from *** percent in 2015 to *** percent in 2016 and then declining to *** percent in 2017.¹⁷⁵ Exports as a share of their total shipments were *** percent in interim 2018, down from *** percent in interim 2017.¹⁷⁶ Responding Korean producers also increased their export

¹⁶⁹ CR/PR at Table V-4; Purchasers' Questionnaire Responses at Questions II-1 and III-26.

¹⁷⁰ CR/PR at Table IV-8.

¹⁷¹ CR/PR at Table IV-8.

¹⁷² CR/PR at Tables I-9, IV-8.

¹⁷³ CR/PR at Tables I-9, IV-8. Responding Korean producers reported that their capacity in interim 2018 was only 1.2 percent lower than in interim 2017 while their production was 38.6 percent lower. *Id.*

¹⁷⁴ We are unpersuaded by Hyundai's argument that the Korean industry's capacity is likely to decline due to a new Korean law that strictly limits the weekly hours that employees may work. Hyundai's Prehearing Brief at 20-21; Hyundai's Posthearing Brief at 3-4; Hearing Tr. at 132-33 (Kang). According to a news article submitted by Hyundai, the Korean parliament passed the law reducing the maximum weekly working hours from 68 to 52 in February 2018. *See South Korea to Cap Working Week at 52 Hours*, Financial Times, July 30, 2018, appended as Exhibit 1 to Hyundai's Posthearing Brief. In its foreign producers' questionnaire response dated May 29, 2018, however, ***. Foreign Producers' Questionnaire Response of Hyundai at Question II-2b. Similarly, in its questionnaire response dated May 21, 2018, ***. Foreign Producers' Questionnaire Response of Hyosung at Question II-2b. We rely on the certified questionnaires responses of Hyundai and Hyosung ***. Further, the large magnitude of the excess capacity possessed by responding foreign producers towards the end of the period of review makes it unlikely that the new law could reduce capacity sufficiently to preclude their ability to significantly increase in exports to the United States. CR/PR at Table IV-8.

¹⁷⁵ CR/PR at Table IV-8.

¹⁷⁶ CR/PR at Table IV-8.

orientation towards the United States between 2015 and 2017, with exports to the United States as a share of their total shipments increasing from *** percent in 2015 to *** percent in 2016 and *** percent in 2017.¹⁷⁷ Exports to the United States as a share of their total shipments were *** percent in interim 2018, compared to *** percent in interim 2017.¹⁷⁸ The United States was the Korean industry's single most important export market for transformers in 2017.¹⁷⁹ Reinforcing the Korean producers' dependence on exports are administrative sanctions imposed by the Korean government against Hyundai for its involvement in bribery schemes and against Hyosung for engaging in antitrust violations, which could make it more difficult for the producers to sell LPTs to government-owned utilities in Korea.¹⁸⁰

¹⁷⁷ CR/PR at Table IV-8. We are also unpersuaded by the respondent interested parties' argument that increased exports to third country markets will somehow prevent their exports to the United States from increasing after revocation. Hyundai's Prehearing Brief at 21; Hyundai's Posthearing Brief at 4-5; Hyosung's Prehearing Brief at 11. Responding Korean producers' exports to third country markets, primarily in Asia and the Middle East, declined as a share of their total shipments from *** percent in 2015 to *** percent in 2017 and was *** percent in interim 2017 and *** percent in interim 2018. CR at IV-13 n.10; PR at IV-6 n.10; CR/PR at Table IV-8. Hyundai explained that Korean exports of LPTs to Saudi Arabia, the United Arab Emirates, and Qatar declined towards the end of the period of review due to low oil prices in 2014 and 2015 that caused the delay or cancellation of power utility and transmission projects. Hyundai's Responses to Commissioner Questions at 18-20. We observe that Korean producers' face competition for sales to Asian customers from the Chinese industry, which is the world's largest producer and exporter of transformers. CR at IV-26-27; PR at IV-12-13.

Although Hyundai projects strong LPT demand growth in the Middle East and Southeast Asia through 2022 (Hyundai's Prehearing Brief at 21; *see also* Hyundai's Posthearing Brief at 4-5), Hyundai also projects that LPT demand will grow in the U.S. market for the foreseeable future. Hyundai's Prehearing Brief at 11-14. Given this, as well as the Korean producers' substantial presence in the U.S. market, export orientation towards the United States, and substantial excess capacity, we find it likely that Korean producers would increase their exports of LPTs to the United States significantly after revocation even if they simultaneously increase their exports of LPTs to third country markets.

¹⁷⁸ CR/PR at Table IV-8.

¹⁷⁹ CR/PR at Table IV-12 (including exports of all transformers exceeding 10 MVA, which includes in-scope and out-of-scope transformers). Korean producers of LPTs are subject to an antidumping duty order imposed by Canada in 2012, which covers the same LPTs within the scope of this review, and an antidumping duty order imposed by Argentina in 2014, which covers the LPTs within the scope of this review as well as some smaller transformers outside the scope. CR at IV-22-23 & nn.15, 20; PR at IV-10 nn.15, 20. These orders would make the U.S. market relatively more attractive in the event of revocation.

¹⁸⁰ Domestic Interested Parties' Prehearing Brief at 39-40, Exhibit 8; Domestic Interested Parties' Posthearing Brief at 6, Exhibits 1, 7. At the hearing, Hyundai stated that the ban no longer applied to Hyundai Electric & Energy Systems after it was spun off from Hyundai Heavy Industry. Hearing Tr. at 163 (Kang), 187 (Kang). At a public hearing before the Canadian International Trade Tribunal on March 18, 2018, however, a Hyundai official testified that the issue of whether it was banned from bidding on LPT projects for KEPCO remained unresolved and that it was banned from bidding on LPT projects for Korea Hydro, as Hyundai pursues an appeal of the ban. Domestic Interested Parties' Posthearing Brief, Exhibit (Continued...)

We are unpersuaded by Hyundai's argument that subject import volume is unlikely to grow after revocation because it will increasingly serve U.S. customers using LPTs produced in the United States by HYPO instead of with LPTs imported from Korea.¹⁸¹ Although HYPO began U.S. shipments of LPTs in January 2012, Hyundai's exports of LPTs from Korea to the United States remained substantial during the 2015-17 period, including exports of LPTs ***, and Hyundai and HYPO ***.¹⁸² Although Hyundai's exports to the United States were only *** MVA in interim 2018, compared to *** MVA in interim 2017, its low rate of capacity utilization in interim 2018, *** percent, and substantial presence in the U.S market would give it a strong incentive to increase its exports to the United States after revocation.¹⁸³ Moreover, increased imports of LPTs from Hyosung more than compensated for the decline in imports of LPTs from Hyundai between 2015 and 2017, causing overall subject import volume and market share to increase over the period.¹⁸⁴ Hyosung has emphasized that it is well positioned to increase its penetration of the U.S. market after revocation.¹⁸⁵

In sum, we find that revocation of the order would likely result in a significant increase in subject import volume within a reasonably foreseeable time.

D. Likely Price Effects

1. The Original Investigation

In the original investigation, the Commission found that significant subject import underselling during the period of investigation caused a shift in market share from the domestic industry to subject imports and significantly suppressed prices for the domestic like product.¹⁸⁶ The Commission began its analysis by reiterating that subject imports and domestically produced LPTs built to the same specifications were highly substitutable, and that price was an

(...Continued)

7 at 209-10. Hyosung has not contested the domestic interested parties' characterization of the ban on its sales of LPTs to KEPCO. See Hyosung's Responses to Commissioner Questions at 4.

¹⁸¹ Hyundai's Prehearing Brief at 19-20; Hyundai's Posthearing Brief at 5-6.

¹⁸² CR/PR at Tables III-1, E-1. Hyundai's exports to the United States increased from *** MVA in 2015 to *** MVA in 2016 before declining to *** MVA in 2017. Foreign Producers' Questionnaire of Hyundai at Question II-11. Although Hyundai reported that it ***, Hyundai's exports of LPTs rated 60 to 299 MVA increased from *** MVA in 2015 to *** MVA in 2016 before declining to a still significant *** MVA in 2017. *Id.* at Questions II-10, 13. Furthermore, Hyundai submitted bids in *** of the *** bidding events in which HYPO participated during the period. CR/PR at Table E-1.

¹⁸³ Foreign Producers' Questionnaire of Hyundai at Question II-11.

¹⁸⁴ See Foreign Producers' Questionnaire of Hyosung at Question II-11.

¹⁸⁵ See Hyosung's Prehearing Brief at 7 ("Hyosung has remained competitive in the U.S. market due to its superior quality lifetime performance"), 8 ("Hyosung . . . offers a full range of LPT products, allowing it to provide more flexible service to meet the need of a variety of customers"), 9 ("Hyosung has been able to leverage its engineering expertise and adaptability to actively pursue and obtain a significant and growing market share in this expanding {renewable energy and natural gas} segment of the market in . . . the United States . . ."); see also Hyosung's Posthearing Brief at 2-3.

¹⁸⁶ Original Determination, USITC Pub. 4346 at 20.

important factor in purchasing decisions.¹⁸⁷ The Commission then considered the extensive bidding data collected from U.S. purchasers in the investigation, including the base price and evaluated cost offered by each bidder and the reasons for accepting or rejecting each bid.¹⁸⁸ In considering these data, the Commission observed that purchasers cited lower overall cost as at least one reason for selecting the winning bidder in a plurality of bidding events, and that there was some transparency in the bidding process because bids submitted to public utilities were public and because purchasers may provide some feedback to bidders.¹⁸⁹

Based on bidding data, the Commission found subject import underselling to be significant.¹⁹⁰ Specifically, the Commission found that suppliers of subject imports won a substantial number of bids when the lowest bid or evaluated cost was the reason for their selection, with such suppliers underbidding domestic producers by 9.7 to 40.3 percent in terms of base price and 3.9 to 19.7 percent in terms of evaluated cost.¹⁹¹ The Commission also found that individual suppliers of subject imports, including HICO, Hyundai, and Iljin, underbid domestic producers in the vast majority of comparisons and in the vast majority of bidding events won by the suppliers, on both an initial price and evaluated cost basis.¹⁹² As further evidence of underselling, the Commission observed that purchasers had confirmed petitioners' lost sales allegations of \$26.1 million, involving 128 units.¹⁹³

The Commission also found that subject imports suppressed domestic like product prices, as the domestic industry's ratio of cost of goods sold to net sales increased steadily from *** percent in 2009 to *** percent in 2011 and *** percent in interim 2012, compared to *** percent in interim 2011.¹⁹⁴ The Commission attributed the industry's inability to increase prices sufficiently to cover its costs, despite growing demand, to the significant and increasing volume of subject imports that underbid the domestic like product.¹⁹⁵

The Commission rejected respondents' argument that competition between subject imports and the domestic like product was limited for LPTs over 300 MVA with high line voltage ratings of 345 kV and above. As the Commission explained, domestic producers submitted bids for LPTs in that range, and bid against Korean suppliers for sales of such LPTs in many instances.¹⁹⁶

The Commission concluded that subject imports had significant adverse effects on domestic like product prices.

¹⁸⁷ Original Determination, USITC Pub. 4346 at 18.

¹⁸⁸ Original Determination, USITC Pub. 4346 at 18.

¹⁸⁹ Original Determination, USITC Pub. 4346 at 18-19.

¹⁹⁰ Original Determination, USITC Pub. 4346 at 19.

¹⁹¹ Original Determination, USITC Pub. 4346 at 19.

¹⁹² Original Determination, USITC Pub. 4346 at 19.

¹⁹³ Original Determination, USITC Pub. 4346 at 20.

¹⁹⁴ Confidential Original Determination at 29.

¹⁹⁵ Original Determination, USITC Pub. 4346 at 20.

¹⁹⁶ Original Determination, USITC Pub. 4346 at 20.

2. The Current Review

As addressed in section III.B.2.c above, the record indicates that there is a high degree of substitutability between subject imports and domestically produced LPTs that are built to the same specifications. The record also indicates that price is an important factor in purchasing decisions, although non-price factors are important as well. While bidding events held by investor-owned utilities are closed, LPTs gain a general understanding of their competitors' pricing through informal feedback from such utilities and through the open bidding events held by public utilities.

The Commission requested U.S. purchasers to provide bid data for their five largest purchases of LPTs since January 1, 2015 that involved at least one bid from a domestic producer and one bid from a Korean firm.¹⁹⁷ For each bidding event, purchasers were requested to report the year, the base MVA, the top MVA, the load loss evaluation (\$ per kW), the number of units, the high line kV, the no load loss evaluation (\$ per kW), the winning bidder, and the reason for the winning bidder.¹⁹⁸ Purchasers were also requested to report information on each bid submitted for a bidding event, including the supplier name, the country, the base price, the evaluated cost, and the reasons for accepting or rejecting the bid.¹⁹⁹ Thirteen purchasers provided usable bid data for 42 bidding events.²⁰⁰

Even with the order in place, bidding data show that subject import underselling remained significant during the period of review. For all reported bidding events, Korean producers underbid domestic producers on 29 of 42 occasions (69.0 percent of the time) with respect to base price, at an average margin of 14.2 percent, and on 29 of 41 occasions (70.7 percent of the time) with respect to evaluated cost, at an average margin of 9.0 percent.²⁰¹ For reported bids won by Korean producers, Korean producers underbid domestic producers on 10 of 11 occasions with respect to both base price and evaluated cost, or 90.9 percent of the time.²⁰²

¹⁹⁷ CR at V-14; PR at V-8.

¹⁹⁸ CR/PR at Table V-5.

¹⁹⁹ CR/PR at Table E-1.

²⁰⁰ CR at V-14; PR at V-8.

²⁰¹ CR/PR at Table V-6, E-1. One responding purchaser reported bidding data concerning base price but not evaluated cost. *Id.*

²⁰² CR/PR at Table V-6. We are unpersuaded by Hyundai's argument that only *** of *** responding purchasers that awarded bids to Korean producers did so on the basis of price. Hyundai's Responses to Commissioner Questions at 5-6, 10-13; Hyundai's Final Comments at 5. Responding purchasers awarded *** of *** projects to Korean producers at least partly on the basis of price, while responding purchasers did not specify the specific factors that led them to award bids to Korean producers for another *** projects. See CR/PR at Table V-5 (*** reported that price was a factor for *** projects, while *** reported either *** or "****" for *** projects). Responding purchasers reported awarding only *** projects to Korean producers for reasons that included no mention of price. *Id.* (*** and ***). As discussed in section III.B.2.c above, price is an important factor in purchasing decisions, although non-price factors are important as well.

Consistent with our finding that subject import volume is likely to increase significantly after revocation, we find that subject import underselling is likely to intensify after revocation as a means for Korean producers to increase their penetration of the U.S. market. The high degree of substitutability between subject imports and the domestic like product and the importance of price in purchasing decisions make underselling an effective strategy for winning bidding events. During the original investigation, the Commission found that significant subject import underselling allowed subject imports to increase their market share at the expense of the domestic industry.²⁰³ Between 2015 and 2017, Korean producers undersold the domestic like product in nearly all of the bidding events they won in which domestic producers were also competing, and increased their share of apparent U.S. consumption by *** percentage points at the domestic industry's expense.²⁰⁴ Absent the disciplining effect of the order, Korean producers would likely lower their bid prices further and increase the proportion of bidding events won against domestic producers toward the higher level that prevailed during the original investigation.²⁰⁵

We also find that the significant increase in low-priced subject import volume that is likely after revocation would depress or suppress domestic like product prices to a significant degree. In the original investigation, the Commission found that significant subject import underselling suppressed domestic like product prices to a significant degree.²⁰⁶ During the period of review, while subject import underselling remained significant, the unit value of the domestic industry's net sales declined from \$*** per MVA in 2015 to \$*** MVA in 2016 and \$*** MVA in 2017, and was \$*** MVA in interim 2018, compared to \$*** MVA in interim 2017.²⁰⁷ At the same time, the industry's ratio of cost of goods sold to net sales increased from

²⁰³ Original Determination, USITC Pub. 4346 at 20.

²⁰⁴ CR/PR at Table I-9. We are unpersuaded by Hyundai's argument that that the *** percentage point increase in subject import market share between 2015 and 2017 was not at the domestic industry's expense because the industry gained market share in the 300 MVA or greater market segment, where subject imports were concentrated, and lost market share primarily to nonsubject imports in the 60-299 MVA market segment. Hyundai's Posthearing Brief at 2-3; Hyundai's Responses to Commissioner Questions at 14-16, 21-22; Hyundai's Final Comments at 2. We recognize that nonsubject imports gained *** percentage points of market share between 2015 and 2017. CR/PR at Table I-9. Nevertheless, the *** percentage points of market share that subject imports captured from the domestic industry during the period was driven by the *** percentage points of market share that subject imports captured from the domestic industry in the 60-299 MVA market segment. *Id.* at Table I-10. Eight of the 11 reported bidding events that Korean producers won against domestic producers involved LPTs in the 60-299 MVA segment, and subject imports undersold the domestic like product in all eight events. *Id.* at Tables V-5, E-1.

²⁰⁵ Korea producers won *** percent of the reported bidding events in which domestic producers participated in the original investigation (** of **) but only 26.2 percent of the reported bidding events in which domestic producers participated during the period of review (11 of 42). Confidential Staff Report, *LPTs from Korea*, Inv. No. 731-TA-1189 (Final), EDIS Doc. No. 620529, at Table V-5; CR/PR at Table V-6.

²⁰⁶ Original Determination, USITC Pub. 4346 at 20.

²⁰⁷ CR/PR at Table III-12.

*** percent in 2015 to *** percent in 2016 and *** percent in 2017.²⁰⁸ The industry’s ratio of cost of goods sold to net sales was *** percent in interim 2018, compared to *** percent in interim 2017.²⁰⁹ The intensification of subject import underselling that we have found likely after revocation would place additional pressure on domestic producers to either reduce their prices or forego price increases that would have otherwise occurred to compete for sales, resulting in the significant depression or suppression of domestic like product prices.

We conclude that revocation of the order would be likely to lead to significant subject import underselling and significant price depression or suppression within a reasonably foreseeable time.

E. Likely Impact²¹⁰

1. The Original Investigation

The Commission found that, by many measures, the domestic industry’s performance improved during the original period of investigation, including capacity, production, shipments, net sales quantity, production related workers, hours worked, and wages paid, as apparent U.S. consumption increased.²¹¹ The industry’s market share and rate of capacity utilization declined, however, and its financial indicators deteriorated.²¹² After posting healthy operating income in 2009, the industry suffered increasing operating losses that peaked in 2011, when subject import volume also peaked, and declining returns on investment and capital expenditures.²¹³ Based on the domestic industry’s loss of market share to subject imports, which significantly underbid and suppressed domestic like product prices, the Commission found a causal nexus between subject imports and the industry’s condition.²¹⁴ Nonsubject imports did not explain the domestic industry’s declining performance, the Commission explained, because nonsubject import market share was highest in 2009, when the industry was profitable, and because subject imports won more bids on the basis of lower prices than nonsubject imports.²¹⁵ Based

²⁰⁸ CR/PR at Table III-12.

²⁰⁹ CR/PR at Table III-12.

²¹⁰ Section 752(a)(6) of the Act states that “the Commission may consider the magnitude of the margin of dumping” in making its determination in a five-year review. 19 U.S.C. § 1675a(a)(6). The statute defines the “magnitude of the margin of dumping” to be used by the Commission in five-year reviews as “the dumping margin or margins determined by the administering authority under section 1675a(c)(3) of this title.” 19 U.S.C. § 1677(35)(C)(iv); see also SAA at 887. In its expedited review of the antidumping duty order on LPTs from Korea, Commerce found likely weighted-average dumping margins up to 29.04 percent. *Large Power Transformers From the Republic of Korea: Final Results of the Expedited First Sunset Review of the Antidumping Duty Order*, 82 Fed. Reg. 51604 (Nov. 7, 2017).

²¹¹ Original Determination, USITC Pub. 4346 at 21-22.

²¹² Original Determination, USITC Pub. 4346 at 21-22.

²¹³ Original Determination, USITC Pub. 4346 at 22.

²¹⁴ Original Determination, USITC Pub. 4346 at 22.

²¹⁵ Original Determination, USITC Pub. 4346 at 22-23.

on the foregoing analysis, the Commission concluded that the domestic industry was materially injured by subject imports.²¹⁶

2. The Current Review

Despite relatively stable apparent U.S. consumption, and despite multiple expansions and improvements within the domestic industry, many of the industry's performance indicators declined during the 2015-17 period. The industry undertook many investments and changes during the period of review. In particular, HYPO began shipments from its U.S. production facility in 2012; SPX completed a 50 percent expansion of its Wisconsin plant that same year, expanding its production capability to LPTs greater than 1,000 MVA; Mitsubishi opened a U.S. production facility in 2013 capable of producing shell transformers from 300 to more than 1,000 MVA; and VA Transformer acquired a facility in Georgia with the technology to produce shell and core form transformers up to 1,400 MVA.²¹⁷

The domestic industry's performance initially improved after imposition of the order. Between 2012 and 2014, the domestic industry's market share increased from *** percent to *** percent, its net sales quantity increased *** percent, its net sales value increased *** percent, and its operating loss declined from negative *** percent of net sales in 2012 to negative *** percent of net sales in 2014.²¹⁸

After 2014, however, the domestic industry's performance began to decline according to most measures. Although the domestic industry's capacity increased from *** MVA in 2015 to *** MVA in 2017, the industry's production declined from *** MVA in 2015 to *** MVA in 2017.²¹⁹ Consequently the industry's rate of capacity utilization declined from *** percent in 2015 to *** percent in 2016 and *** percent in 2017.²²⁰ Both the industry's capacity and production were higher in interim 2018, at *** MVA and *** MVA respectively, than in interim 2017, at *** MVA and *** MVA respectively, resulting in a capacity utilization rate of *** percent in interim 2018, compared to *** percent in interim 2017.²²¹

The domestic industry's employment-related performance measures also declined between 2015 and 2017. The domestic industry's employment declined from *** production and related workers ("PRWs") in 2015 to *** PRWs in 2016 and *** PRWs in 2017.²²² Industry employment was *** PRWs in interim 2018, compared to *** PRWs in 2017.²²³ Similarly, the industry's hours worked, wages paid, and productivity declined by ***, ***, and *** percent,

²¹⁶ Original Determination, USITC Pub. 4346 at 23.

²¹⁷ CR/PR at Table III-1; Hearing Tr. at 36-37 (Jain).

²¹⁸ CR/PR at Tables I-2, III-15.

²¹⁹ CR/PR at Table III-4.

²²⁰ CR/PR at Table III-4.

²²¹ CR/PR at Table III-4.

²²² CR/PR at Table III-11.

²²³ CR/PR at Table III-11.

respectively, between 2015 and 2017, while each indicator was higher in interim 2018 than in interim 2017.²²⁴

The domestic industry's volume-related indicators declined as well. Specifically, the industry's net sales volume declined from *** MVA in 2015 to *** MVA in 2016 and *** MVA in 2017, a level *** percent lower than in 2015.²²⁵ The industry's net sales volume was *** MVA in interim 2018, compared to *** MVA in interim 2017.²²⁶ The domestic industry's U.S. shipments increased from *** MVA in 2015 to *** MVA in 2016 before declining to *** MVA in 2017, a level *** percent lower than in 2015.²²⁷ The industry's U.S. shipments were *** MVA in interim 2018, compared to *** MVA in interim 2017.²²⁸ The domestic industry's U.S. shipments as a share of apparent U.S. consumption declined from *** percent in 2015 to *** percent in 2016 and *** percent in 2017.²²⁹ The industry's market share was *** percent in interim 2018, compared to *** percent in interim 2017.²³⁰

Consistent with the domestic industry's declining production, sales, and market share, the industry's financial performance worsened after 2014. The domestic industry's gross profit declined from \$*** in 2015 to \$*** in 2016 and negative \$*** in 2017.²³¹ The industry's gross profit was negative \$*** in interim 2018 compared to \$*** in interim 2017.²³² The domestic industry's operating loss increased from negative \$*** in 2015 to negative \$*** in 2016 and negative \$*** in 2017, and was negative \$*** in interim 2018 compared to negative \$*** in interim 2017.²³³ As a share of net sales, the industry's operating loss widened from negative *** percent in 2015 to negative *** percent in 2016 and negative *** percent in 2017.²³⁴ The industry's operating loss as a share of net sales was negative *** percent in interim 2018, compared to negative *** percent in interim 2017.²³⁵ The domestic industry's net loss

²²⁴ CR/PR at Tables III-11, C-1. The domestic industry's total hours worked declined from *** hours in 2015 to *** hours in 2016 and *** hours in 2017, and were *** hours in interim 2018 compared to *** hours in interim 2017. *Id.* The industry's wages paid declined from \$*** in 2015 to \$*** in 2016 before increasing to \$*** in 2017, a level still *** percent lower than in 2015. *Id.* The industry's wages paid were \$*** in interim 2018, compared to \$*** in interim 2017. *Id.* The industry's productivity in MVA top rated per hour increased from *** in 2015 to *** in 2016 before declining to *** in 2017, a level *** percent lower than in 2015. *Id.* The industry's productivity in MVA top rated per hour was *** in interim 2018, compared to *** in interim 2017. *Id.*

²²⁵ CR/PR at Tables III-12, C-1.

²²⁶ CR/PR at Table III-12.

²²⁷ CR/PR at Tables III-7, C-1.

²²⁸ CR/PR at Table III-7.

²²⁹ CR/PR at Table I-9.

²³⁰ CR/PR at Table I-9.

²³¹ CR/PR at Table III-12.

²³² CR/PR at Table III-12.

²³³ CR/PR at Table III-12.

²³⁴ CR/PR at Table III-12.

²³⁵ CR/PR at Table III-12.

increased from negative \$*** in 2015 to negative \$*** in 2016 and negative \$*** in 2017.²³⁶ The industry's net loss was negative \$*** in interim 2018, compared to negative \$*** in interim 2017.²³⁷ The industry's capital expenditures and research and development ("R&D") expenses also declined between 2015 and 2017, but were higher in interim 2018 than in interim 2017.²³⁸

Due to significant financial losses stemming from a loss of market share and low capacity utilization, ABB announced the closure of its LPT production facility in St. Louis, Missouri in November 2017.²³⁹ After production at the facility ceased in July 2018, ABB's South Boston, Virginia LPT production facility assumed production of about 70 percent of the production capability of LPTs previously undertaken in St. Louis.²⁴⁰

Based on the domestic industry's deteriorating performance and growing financial losses towards the end of the period of review, we find that the industry is vulnerable to the recurrence or continuation of material injury by reason of subject imports were the order to be revoked. Further increasing the industry's vulnerability are projections that U.S. electricity demand will rise slowly in the reasonably foreseeable future, restraining growth in LPT demand.²⁴¹

As addressed above, we have found that revocation of the antidumping duty order on LPTs from Korea would likely result in a significant increase in subject import volume. In order to increase their penetration of the U.S. market, Korean producers are likely to intensify the already significant level of subject import underselling that prevailed during the period of review, unrestrained by the disciplining effect of the order. The significant increase in low-priced subject imports that we find likely after revocation will likely capture market share from the domestic industry, as in the original investigation. It would also be likely to force domestic producers to reduce their prices or forego price increases to compete for sales, thereby depressing or suppressing domestic like product prices to a significant degree. We find that subject imports, through all these effects, would likely have a significant adverse impact on the domestic industry's production, shipments, sales, market share, and revenues. They would also have a significant adverse impact on the industry's gross profit, operating income, and net income, as well as its ability to raise capital and make and maintain necessary capital investments. We therefore conclude that, if the order were revoked, subject imports would be

²³⁶ CR/PR at Table III-12.

²³⁷ CR/PR at Table III-12.

²³⁸ CR/PR at Table III-16. The domestic industry's capital expenditures declined from \$*** in 2015 to \$*** in 2016 and \$*** in 2017, and were \$*** in interim 2018, compared to \$*** in interim 2017. *Id.* The industry's R&D expenses declined from \$*** in 2015 to \$*** in 2016 and \$*** in 2017, and were \$*** in interim 2018, compared to \$*** in interim 2017. *Id.*

²³⁹ CR/PR at Table III-1; Declaration of Steve Robinson, attached as Exhibit 4 to Domestic Interested Parties' Posthearing Brief, at paras. 3-4.

²⁴⁰ Declaration of Steve Robinson, attached as Exhibit 4 to Domestic Interested Parties' Posthearing Brief, at para. 4.

²⁴¹ See section III.B.2.a above.

likely to have a significant adverse impact on the domestic industry within a reasonably foreseeable time.²⁴²

We have considered whether there are other factors that likely would affect the domestic industry after revocation in the reasonably foreseeable future.²⁴³ We find that

²⁴² We are unpersuaded by Hyundai's argument that subject imports could have no adverse impact on the domestic industry after revocation because it alleges there was no correlation between subject import volume and the domestic industry's declining performance during the period of review. Hyundai's Prehearing Brief at 30-31; Hyundai's Posthearing Brief at 11-13; Hyundai's Final Comments at 2-3. Contrary to the premise of Hyundai's argument, the Commission is not required to show a causal nexus between subject imports under an order being reviewed and any difficulties suffered by the domestic industry during the period of review. *Consolidated Fibers, Inc. v. United States*, 571 F. Supp. 2d 1355, 1365 (Ct. Int'l Trade 2008) (noting that the Commission's task is "not to determine whether the subject imports significantly contributed to the decline of the domestic industry during the POR . . .").

Furthermore, the record shows a correlation between subject imports and the domestic industry's performance during the period of review. As subject import volume and market share declined between 2012 and 2014, the domestic industry's performance improved in terms of market share, net sales quantity, net sales value, and operating income. CR/PR at Tables I-2, III-15. As subject import volume and market share increased between 2015 and 2017, accompanied by significant underselling, these same measures of industry performance declined, along with most other measures. CR/PR at Tables I-2, III-4, 11, 12, and 15. The lower subject import volume and market share in interim 2018 relative to interim 2017 was accompanied by stronger domestic industry performance according to many measures, including production, market share, employment, and net sales volume and value, although the industry's financial performance remained weak. CR/PR at Tables I-9, III-4, 11, and 12. Domestic producers testified at the hearing that intensifying competition from low-priced subject imports contributed significantly to their declining prices and worsening financial performance during the period. See Hearing Tr. at 17-20 (Robinson), 22-25 (Mason), 29-30 (Newman), 32-34 (Blake), 37-38 (Jain), 39 (Gursahaney). Thus, the correlation between subject imports and the domestic industry's performance during the period of review is consistent with the adverse impact that we find likely after revocation of the order.

²⁴³ We are unpersuaded by the respondent interested parties' argument that certain non-price factors contributed to the domestic industry's lagging performance during the period of review, allegedly including the industry's poor quality and customer service and the perception that larger size LPTs are not produced domestically, and that these factors are likely to continue and prevent subject imports from having a significant adverse impact on the industry after revocation. Hyundai's Prehearing Brief at 33; Hyundai's Posthearing Brief at 8; Hyosung's Responses to Commissioner Questions at 7-8; Hyosung's Final Comments at 1-4; Hearing Tr. at 133-34 (Kang). As addressed in section III.B.2.c above, most responding purchasers reported that domestically produced LPTs are comparable to subject imports in terms of all 24 factors that influence purchasing, including product consistency, product range, quality meets industry standards, quality exceeds industry standards, responsiveness of supplier, and technical support/service. CR/PR at Table II-10. Similarly, most responding purchasers reported that domestically produced LPTs are always or frequently interchangeable with subject imports and that both domestic and Korean producers are always or usually able to meet minimum quality specifications. CR/PR at Tables II-11-12. The record also shows that domestic producers offer a full range of LPTs, ranging from 60 to 700 or greater MVA and from less than 345 kV to 765 kV or greater, with multiple (Continued...)

nonsubject imports are unlikely to prevent subject import volume from increasing significantly after revocation. Substantial nonsubject import volume during both the original period of investigation and the current period of review, ranging from *** to *** percent of apparent U.S. consumption, did not prevent subject import volume from increasing significantly at the domestic industry's expense over both periods.²⁴⁴ Moreover, nonsubject import bid prices were generally higher than subject import bid prices during the period of review in terms of both base price and evaluated cost.²⁴⁵

Competition between subject imports and the domestic industry is likely to remain intense after revocation, irrespective of competition from nonsubject imports. We have found a high degree of substitutability between subject imports and domestically produced LPTs and that eight of the 12 responding purchasers reporting qualified Korean suppliers also reported at least one domestic supplier qualified to supply the same MVA and kV range as the qualified Korean supplier.²⁴⁶ Korean producers competed against domestic producers in 84.7 percent of the reported bidding events since January 1, 2015 in which Korean producers participated, and are either qualified to sell or sold LPTs to responding purchasers that account for *** percent of reported LPT units open to bidding through 2019.²⁴⁷ For all these reasons, we find that if the order were revoked, subject imports would likely have significant adverse effects on the domestic industry that are distinct from any adverse effects of nonsubject imports.²⁴⁸

(...Continued)

domestic producers participating in the over 300 MVA segment. CR/PR at Table III-16. Thus, the record does not support the respondent interested parties' argument that subject imports enjoyed a significant advantage over domestically produced LPTs in terms of non-price factors.

Further belying respondents' argument that non-price factors hampered the domestic industry's ability to compete, bidding data show that domestic producer bid prices were higher than Korean producer bid prices in 8 of the 15 bids won by domestic producers, suggesting that non-price factors helped domestic producers win a majority of these bids. CR/PR at Table V-6. By contrast, Korean producer bid prices were lower than domestic producer bid prices in 10 of the 11 bids won by Korean producers, suggesting that purchasers were not choosing the subject imports because of non-price factors. *Id.*

²⁴⁴ CR/PR at Tables I-9, C-2.

²⁴⁵ CR at V-17; PR at V-8. Out of 42 reported bidding events, a Korean producer offered the lowest base price in 24 events and the lowest evaluated cost in 21 events, a nonsubject producer offered the lowest base price in 12 events and the lowest evaluated cost in 10 events, and a domestic producer offered the lowest base price in 6 events and the lowest evaluated cost in 11 events. *Id.*

²⁴⁶ CR at II-24-25; PR at II-16.

²⁴⁷ CR at V-14; PR at V-8; CR/PR at Table V-4; Purchasers' Questionnaire Responses at Questions II-1 and III-26.

²⁴⁸ We are unpersuaded by the respondent interested parties' argument that any increase in subject import volume after revocation would likely come at the expense of nonsubject imports rather than the domestic industry. Hyundai's Prehearing Brief at 24; Hyundai's Posthearing Brief at 7; Hyosung's Prehearing Brief at 11-12. The record shows that the domestic industry gained most of the market share lost by subject imports after imposition of the order in 2011; between 2011 and 2017, subject imports lost *** percentage points of market share while the domestic industry gained *** percentage points and nonsubject imports gained *** percentage points. CR/PR at Tables I-1-1. Given (Continued...)

IV. Conclusion

For the foregoing reasons, we determine that revocation of the antidumping duty order on LPTs from Korea would likely lead to the continuation or recurrence of material injury to an industry in the United States within a reasonably foreseeable time.

(...Continued)

this, by Hyundai's own admission that revocation of the order would likely cause these market share shifts to "reverse," the increase in subject import volume after revocation that we have found likely would come largely at the expense of the domestic industry. See Hyundai's Posthearing Brief at 7.

PART I: INTRODUCTION

BACKGROUND

On July 3, 2017, the U.S. International Trade Commission (“Commission” or “USITC”) gave notice, pursuant to section 751(c) of the Tariff Act of 1930, as amended (“the Act”),¹ that it had instituted a review to determine whether revocation of the antidumping duty order on large power transformers (“LPTs”) from Korea would likely lead to the continuation or recurrence of material injury to a domestic industry.² ³ On October 6, 2017, the Commission determined that it would conduct a full review pursuant to section 751(c)(5) of the Act.⁴ The following tabulation presents information relating to the background and schedule of this proceeding:⁵

Effective date	Action
August 31, 2012	Commerce’s antidumping duty order on LPTs from Korea (77 FR 53177)
July 3, 2017	Commission’s institution of five-year review (82 FR 30896)
July 3, 2017	Commerce’s initiation of five-year review (82 FR 30844)
October 6, 2017	Commission’s determination to conduct full five-year review (82 FR 49229, October 24, 2017)
November 7, 2017	Commerce’s final results of expedited five-year review of the antidumping duty order (82 FR 51604)
April 3, 2018	Commission’s scheduling of the review (83 FR 15398)
July 26, 2018	Commission’s hearing
September 12, 2018	Scheduled date for the Commission’s vote
September 26, 2018	Scheduled date for the Commission’s determination and views

¹ 19 U.S.C. 1675(c).

² *Large Power Transformers from Korea; Institution of a Five-Year Review*, 82 FR 30896, July 3, 2017. All interested parties were requested to respond to this notice by submitting the information requested by the Commission.

³ In accordance with section 751(c) of the Act, the U.S. Department of Commerce (“Commerce”) published a notice of initiation of five-year review of the subject antidumping order concurrently with the Commission’s notice of institution. *Initiation of Five-Year (“Sunset”) Reviews*, 82 FR 30844, July 3, 2017.

⁴ *Large Power Transformers From Korea; Notice of Commission Determination To Conduct a Full Five-Year Review*, 82 FR 49229, October 24, 2017. The Commission found that both the domestic and respondent interested party group responses to its notice of institution were adequate.

⁵ The Commission’s notice of institution, notice to conduct full review, scheduling notice, and statement on adequacy are referenced in appendix A and may also be found at the Commission’s web site (internet address www.usitc.gov). Commissioners’ votes on whether to conduct expedited or full reviews may also be found at the web site. Appendix B presents the witnesses appearing at the Commission’s hearing.

The original investigations

The original investigation resulted from petitions filed by ABB, Inc. (“ABB”), Cary, North Carolina; Delta Star Inc., (“Delta Star”), Lynchburg, Virginia; and Pennsylvania Transformer Technology Inc. (“PTTI”), Canonsburg, Pennsylvania, on June 14, 2011, alleging that an industry in the United States is materially injured and threatened with material injury by reason of less-than-fair-value (“LTFV”) imports of LPTs from Korea. Following notification of a final determination by Commerce that imports of LPTs from Korea were being sold at LTFV, the Commission determined on August 24, 2012 that a domestic industry was materially injured by reason of LTFV imports of LPTs from Korea.⁶ Commerce published the antidumping duty order on LPTs from Korea on August 31, 2012.⁷

RELATED INVESTIGATIONS

On June 14, 1972, the U.S. Department of Treasury issued antidumping duty findings on LPTs from France, Italy, and Japan.⁸ These findings were revoked by Commerce as of January 1, 2000.⁹

SUMMARY DATA

Table I-1 presents a summary of data from the original investigations and the current full five-year reviews.¹⁰

⁶ *Large Power Transformers from Korea, Inv. No. 731-TA-1189 (Final)*, USITC Publication 4346, August 2012.

⁷ *Large Power Transformers from the Republic of Korea: Antidumping Duty Order*, 77 FR 53177, August 31, 2012.

⁸ 37 FR 11772, June 14, 1972. The scope of the 1972 findings included “all transformers rated 10 MVA or above, by whatever name designated, used in the generation, transmission, distribution, and utilization of electrical power, including but not limited to shunt reactors, autotransformers, rectifier transformers, and power rectifier transformers.” *Large Power Transformers from France, Italy, Japan, Switzerland, and the United Kingdom*, United States Tariff Commission Publication 476, April 1972.

⁹ *Final Results of Sunset Review and Revocation of Antidumping Findings: Large Power Transformers from Italy, et al.*, 63 FR 54441, October 9, 1998.

¹⁰ The size of an LPT is determined by the load measured by megavolt-amperes (“MVA”), the secondary output voltage, and the primary input voltage. For a more detailed discussion, please refer to Part I, “The Product: Description and Applications.” In the original investigation, the Commission determined to use MVA in its analysis, rather than units because transformer size is determined on the basis of MVA ratings, and the sizes of LPTs range widely. The Commission also elected not to focus on the values of LPTs, because value-based measures may be distorted by changes in product mix and because subject import unit values are sold at less than fair value. *Large Power Transformers from Korea, Investigation No. 731-TA-1189 (Final)*, USITC Publication 4346, August 2012, p. I-13, n. 82.

Table I-1

LPTs: Comparative data from the original investigation and current review, by terminal year, 2011 and 2017

Item	Original investigation	First review
	2011	2017
	Quantity (MVA top rated)	
U.S. consumption quantity	137,243	***
	Share of quantity (percent)	
Share of U.S. consumption:		
U.S. producers' share	16.1	***
U.S. importers' share:		
Korea	***	***
Nonsubject sources	***	***
All import sources	83.9	***
	Quantity (MVA top rated); value (1,000 dollars); and unit value (dollars per MVA top rated)	
U.S. imports.--		
Korea		
Quantity	***	***
Value	***	***
Unit value	\$***	\$***
Nonsubject sources:		
Quantity	***	***
Value	***	***
Unit value	\$***	\$***
All import sources:		
Quantity	115,177	***
Value	845,310	***
Unit value	\$7,339	\$***

Table continued on next page.

Table I-1—Continued

LPTs: Comparative data from the original investigation and current review, by terminal year, 2011 and 2017

Item	Original investigation	First review
	2011	2017
	Quantity (MVA top rated); value (1,000 dollars); and unit value (dollars per MVA top rated)	
U.S. industry:		
Capacity (quantity)	59,439	***
Production (quantity)	24,049	***
Capacity utilization (percent)	40.5	***
U.S. shipments:		
Quantity	22,066	***
Value	207,349	***
Unit value	\$9,397	\$***
Production workers	***	***
Hours worked (1,000)	***	***
Wages paid (1,000 dollars)	***	***
Hourly wages	\$***	\$***
Productivity (MVA top rated per 1,000 hour)	***	***
Financial data:		
Net sales:		
Quantity	***	***
Value	***	***
Unit value	\$***	\$***
Cost of goods sold	***	***
Gross profit or (loss)	***	***
SG&A expense	***	***
Operating income or (loss)	***	***
Unit COGS	***	***
Unit operating income	\$***	\$***
COGS/Sales (percent)	***	***
Operating income or (loss)/ Sales (percent)	***	***

Note.--In the original investigation, value data for apparent U.S. consumption were not reported, as volume expressed in MVA (rather than value) was deemed to be the most reasonable basis for measuring apparent U.S. consumption and market share. *Large Power Transformers from Korea, Investigation No. 731-TA-1189 (Final)*, USITC Publication 4346, August 2012, p. I-3, n. 6.

Source: Office of Investigations memorandum INV-KK-082 (July 30, 2012) and data submitted in response to Commission questionnaires.

Table I-2 and figure I-1 present apparent U.S. consumption since the original investigation. Apparent U.S. consumption fluctuated during 2012-17, ending *** percent higher in 2017 than in 2012. U.S. producers' U.S. shipments increased each year during 2012-16, and then declined in 2017, ending *** percent higher than in 2012. U.S. importers' U.S. shipments of imports from Korea declined by *** percent in 2013 and then increased each year through 2016, but were *** percent lower in 2017 than in 2012. U.S. importers' U.S. shipments of imports from nonsubject sources were *** percent higher in 2017 than in 2012.

Table I-2
LPTs: Apparent U.S. consumption, 2012-17

* * * * *

Figure I-1
LPTs: Historical apparent U.S. consumption, 2012-17

* * * * *

STATUTORY CRITERIA AND ORGANIZATION OF THE REPORT

Statutory criteria

Section 751(c) of the Act requires Commerce and the Commission to conduct a review no later than five years after the issuance of an antidumping or countervailing duty order or the suspension of an investigation to determine whether revocation of the order or termination of the suspended investigation “would be likely to lead to continuation or recurrence of dumping or a countervailable subsidy (as the case may be) and of material injury.”

Section 752(a) of the Act provides that in making its determination of likelihood of continuation or recurrence of material injury—

(1) IN GENERAL.-- . . . the Commission shall determine whether revocation of an order, or termination of a suspended investigation, would be likely to lead to continuation or recurrence of material injury within a reasonably foreseeable time. The Commission shall consider the likely volume, price effect, and impact of imports of the subject merchandise on the industry if the order is revoked or the suspended investigation is terminated. The Commission shall take into account--

- (A) its prior injury determinations, including the volume, price effect, and impact of imports of the subject merchandise on the industry before the order was issued or the suspension agreement was accepted,*
- (B) whether any improvement in the state of the industry is related to the order or the suspension agreement,*
- (C) whether the industry is vulnerable to material injury if the order is revoked or the suspension agreement is terminated, and*

(D) in an antidumping proceeding . . . , (Commerce's findings) regarding duty absorption . . .

(2) VOLUME.--In evaluating the likely volume of imports of the subject merchandise if the order is revoked or the suspended investigation is terminated, the Commission shall consider whether the likely volume of imports of the subject merchandise would be significant if the order is revoked or the suspended investigation is terminated, either in absolute terms or relative to production or consumption in the United States. In so doing, the Commission shall consider all relevant economic factors, including--

(A) any likely increase in production capacity or existing unused production capacity in the exporting country,

(B) existing inventories of the subject merchandise, or likely increases in inventories,

(C) the existence of barriers to the importation of such merchandise into countries other than the United States, and

(D) the potential for product-shifting if production facilities in the foreign country, which can be used to produce the subject merchandise, are currently being used to produce other products.

(3) PRICE.--In evaluating the likely price effects of imports of the subject merchandise if the order is revoked or the suspended investigation is terminated, the Commission shall consider whether--

(A) there is likely to be significant price underselling by imports of the subject merchandise as compared to domestic like products, and

(B) imports of the subject merchandise are likely to enter the United States at prices that otherwise would have a significant depressing or suppressing effect on the price of domestic like products.

(4) IMPACT ON THE INDUSTRY.--In evaluating the likely impact of imports of the subject merchandise on the industry if the order is revoked or the suspended investigation is terminated, the Commission shall consider all relevant economic factors which are likely to have a bearing on the state of the industry in the United States, including, but not limited to--

(A) likely declines in output, sales, market share, profits, productivity, return on investments, and utilization of capacity,

(B) likely negative effects on cash flow, inventories, employment, wages, growth, ability to raise capital, and investment, and

(C) likely negative effects on the existing development and production efforts of the industry, including efforts to develop a derivative or more advanced version of the domestic like product.

The Commission shall evaluate all such relevant economic factors . . . within the context of the business cycle and the conditions of competition that are distinctive to the affected industry.

Section 752(a)(6) of the Act states further that in making its determination, “the Commission may consider the magnitude of the margin of dumping or the magnitude of the net countervailable subsidy. If a countervailable subsidy is involved, the Commission shall consider information regarding the nature of the countervailable subsidy and whether the subsidy is a subsidy described in Article 3 or 6.1 of the Subsidies Agreement.”

Organization of report

Information obtained during the course of the review that relates to the statutory criteria is presented throughout this report. A summary of trade and financial data for LPTs as collected in the review is presented in appendix C. U.S. industry data are based on the questionnaire responses of seven U.S. producers of LPTs that are believed to have accounted for the vast majority of domestic production of LPTs in 2017. U.S. import data and related information are based on the questionnaire responses of ten U.S. importers of LPTs that are believed to have accounted for nearly all subject U.S. imports during 2017. Foreign industry data and related information are based on the questionnaire responses of four producers of LPTs. The four producers in Korea accounted for all or virtually all of total LPT production in Korea, based on their estimates in questionnaire responses. Responses by U.S. producers, importers, purchasers, and foreign producers of LPTs to a series of questions concerning the significance of the existing antidumping duty order and the likely effects of revocation of the order are presented in appendix D.

COMMERCE’S REVIEWS

Administrative reviews¹¹

As shown in table I-3, Commerce has completed four administrative reviews of the outstanding antidumping duty order on LPTs from Korea.¹²

¹¹ Commerce has not concluded any changed circumstances reviews, critical circumstances reviews, or issued anti-circumvention findings, since the completion of the original determination. In addition, Commerce has not issued any duty absorption findings or any company revocations or scope rulings since the imposition of the order.

On December 17, 2017, Commerce self-initiated a changed circumstances review regarding the spinoff of Hyundai Electric & Energy System Co., Ltd from Hyundai Heavy Industries Co., Ltd. *Large Power Transformers From the Republic of Korea: Initiation of Antidumping Duty Changed Circumstances Review*, 82 FR 57210, December 4, 2017.

¹² For previously reviewed or investigated companies not included in an administrative review, the cash deposit rate continues to be the company-specific rate published for the most recent period.

Table I-3**LPTs: Administrative reviews of the antidumping duty order on imports from from Korea**

Date results published (as amended)	Period of review	Producer or exporter	Margin (percent)
82 FR 51395 November 6, 2017	February 16, 2012 - July 31, 2013	Hyosung Corporation	9.09
		Hyundai Heavy Industries Co., Ltd.	13.82
		ILJIN Electric Co., Ltd.	11.73
		ILJIN	11.73
		LSIS Co., Ltd.	11.73
81 FR 27088 May 5, 2016	August 1, 2013 - July 31, 2014	Hyosung Corporation	7.89
		Hyundai Heavy Industries Co., Ltd.	4.07
		ILJIN Electric Co., Ltd.	5.98
		ILJIN	5.98
		LSIS Co., Ltd.	5.98
82 FR 13432 March 13, 2017	August 1, 2014 - July 31, 2015	Hyosung Corporation	2.99
		Hyundai Heavy Industries Co., Ltd.	60.81
		ILJIN Electric Co., Ltd.	2.99
		ILJIN	2.99
		LSIS Co., Ltd.	2.99
83 FR 11679 March 16, 2018	August 1, 2015 - July 31, 2016	Hyosung Corporation	60.81
		Hyundai Heavy Industries Co., Ltd.	60.81
		ILJIN Electric Co., Ltd.	60.81
		ILJIN	60.81
		LSIS Co., Ltd.	60.81

Source: Cited Federal Register notices.

Five-year review

Commerce has issued the final results of its expedited review with respect to Korea, determining that revocation of the order on LPTs from Korea would be likely to lead to continuation or recurrence of dumping and that the magnitude of the margin likely to prevail would be weighted-average dumping margins up to 29.04 percent.¹³ In the original investigation, Commerce calculated dumping margins of 29.04 percent for Hyosung Corporation, 14.95 percent for Hyundai Heavy Industries Co., Ltd., and 22.00 percent for all others.¹⁴

¹³ *Large Power Transformers From the Republic of Korea: Final Results of the Expedited First Sunset Review of the Antidumping Duty Order*, 82 FR 51604, November 7, 2017.

¹⁴ *Large Power Transformers from the Republic of Korea: Final Determination of Sales at Less Than Fair Value*, 77 FR 40857, July 11, 2012.

THE SUBJECT MERCHANDISE

Commerce's scope

In the current proceeding, Commerce has defined the scope as follows:¹⁵

Large liquid dielectric power transformers (LPTs) having a top power handling capacity greater than or equal to 60,000 kilovolt amperes (60 megavolt amperes), whether assembled or unassembled, complete or incomplete.

Incomplete LPTs are subassemblies consisting of the active part and any other parts attached to, imported with or invoiced with the active parts of LPTs. The "active part" of the transformer consists of one or more of the following when attached to or otherwise assembled with one another: The steel core or shell, the windings, electrical insulation between the windings, the mechanical frame for an LPT.

The product definition encompasses all such LPTs regardless of name designation, including but not limited to step-up transformers, step-down transformers, autotransformers, interconnection transformers, voltage regulator transformers, rectifier transformers, and power rectifier transformers.

Tariff treatment

LPTs are classifiable in the Harmonized Tariff Schedule of the United States ("HTS") under subheadings 8504.23.00 and 8504.90.96 and reported for statistical purposes under statistical reporting number 8504.23.0045, 8504.23.0080, 8504.90.9634, 8504.90.9638, 8504.90.9642, 8504.90.9646.¹⁶ The general duty rates for these subheadings are 1.6 and 0.6 percent ad valorem, respectively. Goods originating in Korea under the terms of HTS general note 33 are eligible for duty-free entry upon importer claim. Decisions on the tariff classification and treatment of imported goods are within the authority of U.S. Customs and Border Protection.

¹⁵ *Large Power Transformers From the Republic of Korea: Final Results of the Expedited First Sunset Review of the Antidumping Duty Order*, 82 FR 51604, November 7, 2017.

¹⁶ On July 1, 2013, 8504.23.0045 replaced 8504.23.0040. On January 1, 2015, 8504.90.9540 was divided into 8504.90.9534, 8504.90.9538, 8504.90.9542, 8504.90.9546. On July 1, 2016, these were replaced by 8504.90.9634, 8504.90.9638, 8504.90.9642, 8504.90.9646.

THE PRODUCT

Description and applications¹⁷

Description

LPTs are large, heavy pieces of capital equipment (figure I-2). There is substantial variation in the dimensions and weight of individual LPTs. A typical three phase, 75 MVA transformer weighs about 110 tons and is about 25 feet long, 16 feet wide, and 20 feet high. A typical 750 MVA transformer, on the other hand, weighs about 410 tons and is 40 feet long, 56 feet wide, and 45 feet high (table I-4).¹⁸ Their life spans range from 15 to 40 years, though their targeted life span is around 30 years.

Figure I-2
LPTs: Installed large power transformer

* * * * *

Table I-4
LPTs: Typical characteristics, 2011

Voltage rating (Primary-Secondary)	MVA rating	Weight	Dimensions (feet) (Length x Width x Height)
Transmission transformer			
Three Phase			
230–115kV	300	170 tons (340,000 lbs.)	27 x 21 x 25
345–138kV	500	335 tons (670,000 lbs.)	25 x 45 x 30
765–138kV	750	410 tons (820,000 lbs.)	40 x 56 x 45
Single Phase			
765–345kV	500	235 tons (470,000 lbs.)	30 x 40 x 40
Generator step-up transformer			
Three Phase			
115–13.8kV	75	110 tons (220,000 lbs.)	25 x 16 x 20
345–13.8kV	300	185 tons (370,000 lbs.)	40 x 21 x 27
Single Phase			
345–22kV	300	225 tons (450,000 lbs.)	20 x 35 x 30
765–26kV	500	325 tons (650,000 lbs.)	25 x 33 x 40

Source: DOE, *Large Power Transformers and the U.S. Electric Grid*, April 2014, p. 7.

¹⁷ Unless otherwise noted, this information is based on *Large Power Transformers from Korea, Inv. No. 731-TA-1189 (Final)*, USITC Publication 4346 (August 2012), pp. I-5–I-10.

¹⁸ U.S. Department of Energy (DOE), *Large Power Transformers and the U.S. Electric Grid*, April 2014, p. 7.

LPTs use electromagnetic induction between circuits to increase, decrease, or regulate power. Electromagnetic induction takes advantage of the fact that electricity moving through a conductor creates a magnetic field. Induction occurs when that electromagnetic field crosses a second electrical conductor and thereby generates a voltage in the second conductor although the two conductors are not directly connected. This requires a fluctuating magnetic field typically generated by alternating current entering into an input conductor (figure I-3).

Figure I-3
LPTs: Functioning of a transformer

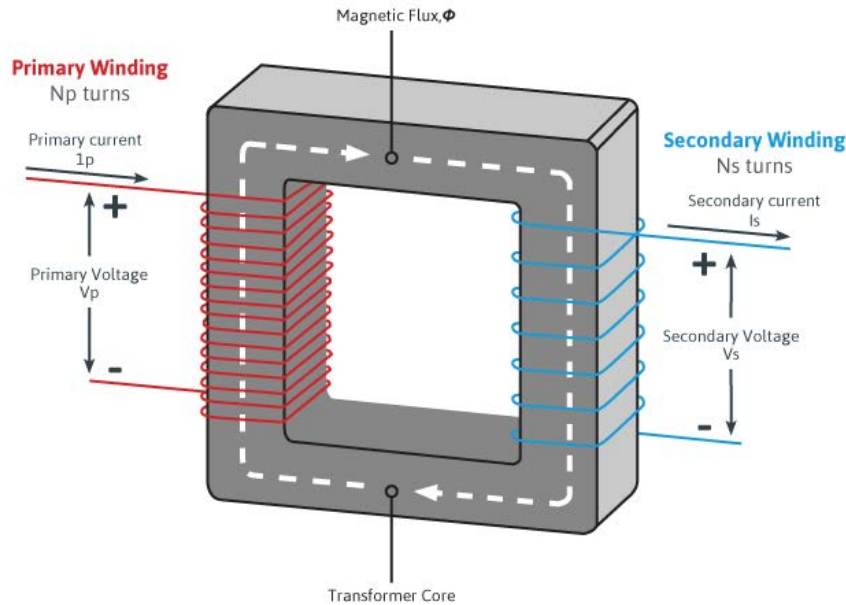

Source: AGW Electronics Website, <https://www.agw.co.uk/blog/article/the-difference-between-inductors-and-transformers> (accessed July 9, 2018).

LPTs have an “active part” where the electromagnetic induction occurs that consists of the core, the windings, and electrical insulation between the windings (figure I-4). The core is made of highly permeable grain-oriented, electrical steel (“GOES”), which is wound with primary (electrical power input) and secondary (output) conductors. The core is made of very thin GOES that is laser scribed and coated with a glass film known as carlite. The core contains the magnetic flux generated by the alternating current moving through the primary conductor. The size of the core is minimized to reduce electrical losses and to reduce the size of the LPT for transport through tunnels and under bridges.

Figure I-4
LPTs: Large power transformer showing major components

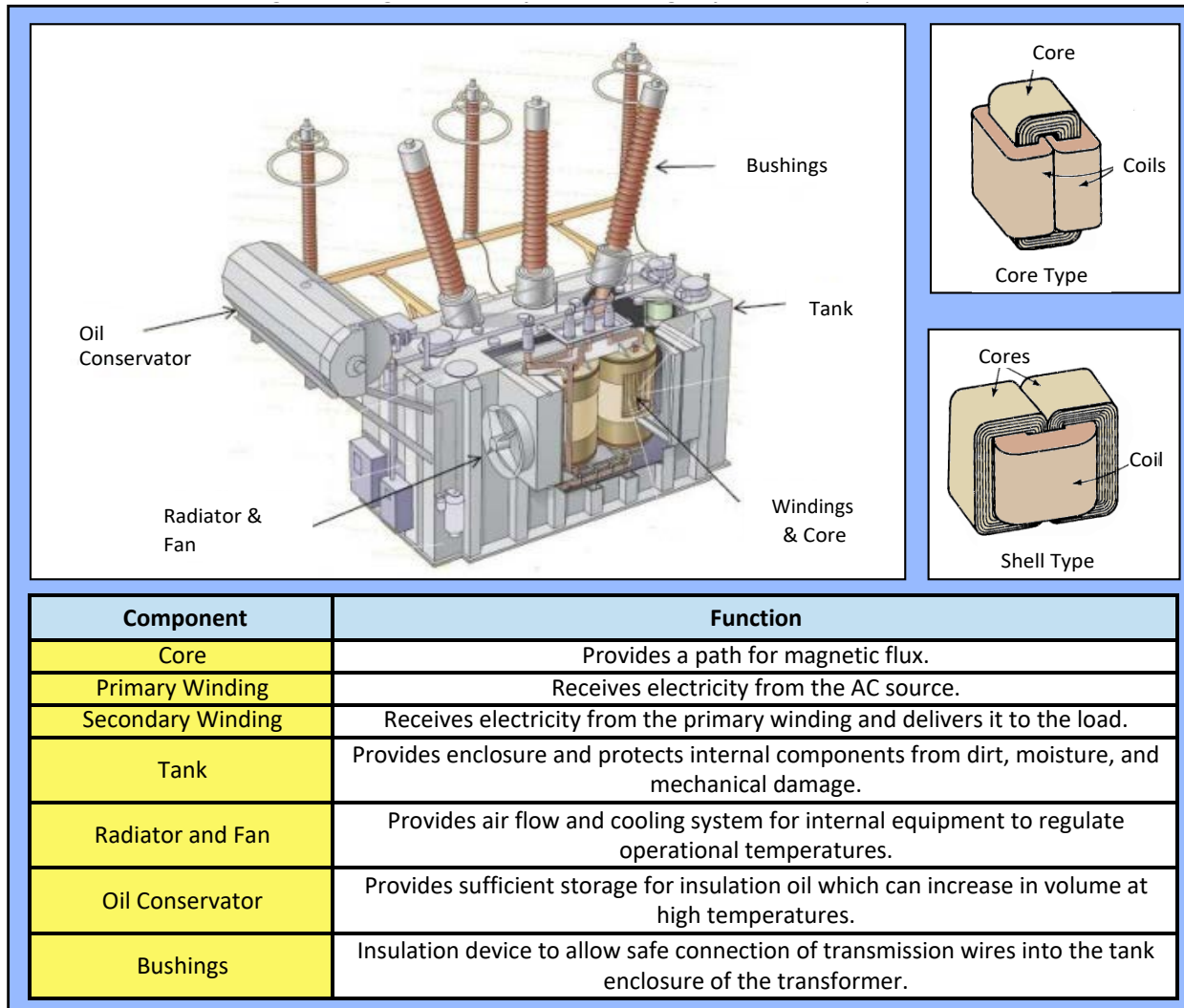

Source: DOE, *United States Electricity Industry Primer*, July 2015, p.17.

Windings are the primary and secondary conductors that are wound around the core. The windings are usually comprised of thin strands of copper wire insulated with paper. Between the windings are paper insulation and spacers of pressboard. Typically, the low voltage winding is placed closest to the core and the high voltage winding is placed outside the low voltage winding, which minimizes the amount of insulation required. The pattern of the windings varies depending on the size, type, and design of the transformer and the voltage and the current (figure I-5). The ratio of turns between the primary and secondary windings is what determines the output voltage. The winding with more turns is the high voltage winding and the one with fewer turns is the low voltage winding. Inserting taps into the winding can change the ratio of the turns and, therefore, the output voltage. These taps can be changed either manually or automatically by a motor.

Figure I-5
LPTs: Examples of windings

* * * * *

LPTs are produced as “single-phase” or “three-phase” models. A single-phase LPT has one primary and secondary set of windings, while a three-phase LPT has three primary and secondary windings around three core limbs. With alternating current, the voltage and current rise and fall along a sine wave, thus the current periodically stops. With three-phase transformers, when the current stops in one phase it is flowing in the other two so the output does not stop. ***.¹⁹

There are two typical configurations of the core and windings, the core form and the shell form (figure I-6). In the shell form, the windings of the primary and secondary inputs are wrapped around the center leg of the magnetic core, in rectangular shaped or “pancake” windings, and more of the windings are enclosed by the core. Shell form LPTs use more GOES than core types. In performance, shell form LPTs are more resilient to short circuits in the transmission system and are frequently used in industrial applications, such as steel mills where short circuits frequently occur.

The active part of the transformer is placed inside of a metal tank. This tank is filled with a fluid, such as mineral oil, natural esther (from plant seed oils), or synthetic esther (from chemicals), which dissipate heat generated by the transformer.²⁰ As the oil heats up it circulates to a radiator where it is cooled as the heat dissipates. Fans are generally attached to aid in cooling and heat exchangers may also be used. As the oil expands, it may travel to a separate tank attached to a frame called an oil conservator.

¹⁹ *Investigation No. 731-TA-1189 (Final): Large Power Transformers from Korea—Staff Report*, INV-KK-082, July 30, 2012, p. I-11.

²⁰ Siemens, “Alternative Transformer Fluids,” n.d., pp. 6, 13, 15, 18–20, 23, https://www.siemens.com/content/dam/internet/siemens-com/global/products-services/energy/high-voltage/transformers/news_pdf/news_pdf_en/siemens-transformers-news-alternative-transformer-fluids.pdf (accessed June 20, 2018); Bureau of Reclamation, “Reclamation Awards \$37 Million Contract to Replace Glen Canyon Powerplant Transformers,” July 17, 2015, <https://www.usbr.gov/newsroom/newsrelease/detail.cfm?RecordID=49787>.

Figure I-6
LPTs: Core form (top) and shell form (bottom) configurations of core and windings

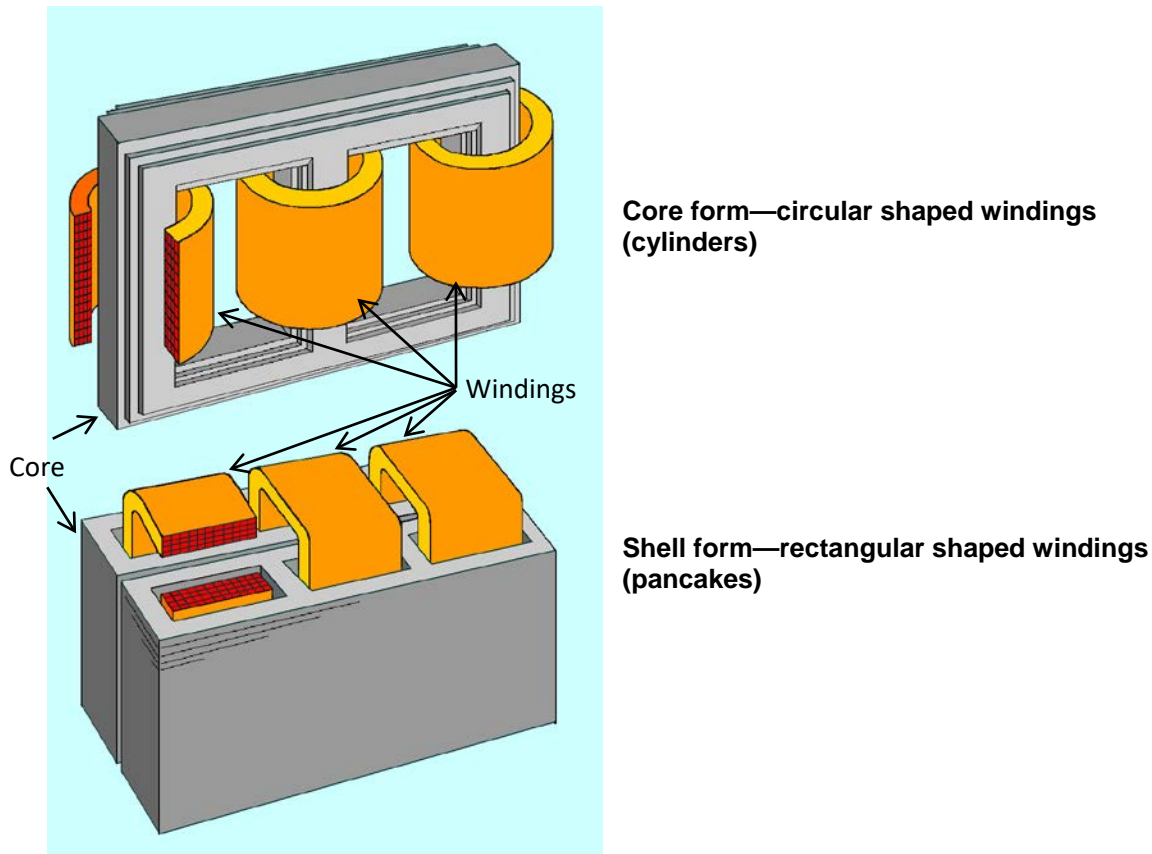

Source: *Large Power Transformers from Korea, Inv. No. 731-TA-1189 (Final)*, USITC Publication 4346, August 2012, p. I-9.

Bushings are used to connect transmission lines to the LPT ***.²¹ A single-phase transformer has four bushings and a three-phase transformer has six bushings. Other parts include tap changers, power cable connectors, gas-operated relays (to detect certain types of problems and minimize subsequent damage within the transformers), thermometers, pressure relief devices, dehydrating breathers, oil level indicators, and other controls. Sensors incorporated into a transformer may monitor a range of operating conditions, and related monitoring and control equipment and software may record the data, automatically control certain functions (such as the level of cooling), allow for remote monitoring, and perform condition analysis.²² Some transformers also have bullet-resistant shielding to increase the physical security of the transformers.²³

²¹ *Investigation No. 731-TA-1189 (Final): Large Power Transformers from Korea—Staff Report*, INV-KK-082, July 30, 2012, p. I-12.

²² ABB Website, <https://new.abb.com/products/transformers/service/advanced-services/coretec4> and <https://new.abb.com/products/transformers/service/advanced-services/coretec> (accessed June 20, 2018); ABB, “ABB Transformer Intelligence Enables North American Utilities to Boost Efficiency and Cut
(continued...)”

Ratings

The size of an LPT is determined by the load measured by megavolt-amperes (“MVA”), the secondary output voltage, and the primary input voltage. In the original investigations, the MVA capacity was used in defining LPTs. The MVA rating system is an industry standard and is based on the cooling system. ***.²⁴ Typically, customer requests for bids will specify the MVA for the transformer at 55 degrees Celsius and also at one or two stages of forced cooling. These ratings are displayed as three numbers; for example, 115/153/192 MVA. The higher ratings reflect the capacity of the transformer with more cooling (more fans and pumps running). The first rating is “oil natural, air natural,” meaning that the fans are not aiding the cooling, and the second and third ratings are with progressively more cooling added. In some generation plants where transformers may be running at full capacity all of the time, they may only have a single rating.

Losses

LPTs are more than 99 percent efficient. There are, however, several types of power losses in LPTs, including no-load losses, load losses, and auxiliary losses. According to the Copper Development Association, “No-load losses are caused by the magnetizing current needed to energize the core of the transformer, and do not vary according to the loading on the transformer. They are constant and occur 24 hours a day, 365 days a year, regardless of the load...” Load losses are primarily due to the resistance of the copper conductor and eddy currents induced in the core by the magnetic field. Auxiliary losses are the power required for fans and other electrical equipment.

(...continued)

Costs,” News release, May 2, 2016, <http://www.multivu.com/players/uk/7818851-abb-launch-transformer-intelligence/>; Siemens Website, <https://www.energy.siemens.com/us/en/services/power-transmission-distribution/transformer-lifecycle-management/transformer-monitoring-diagnostic-system.htm> (accessed June 20, 2018).

²³ In April 2013, a sniper fired into Pacific Gas and Electric Co.’s Metcalf substation, leading to an increased focus on transformer security and grid resiliency. A high-powered rifle was also fired into a transformer at Garkane Energy Cooperative’s Buckskin Substation, in Utah. Hearing transcript (Newman), p. 104; Siemens Website, <https://w3.usa.siemens.com/smartgrid/us/en/newsletters/archive/pages/bullet-resistant-power-transformers.aspx> (accessed July 20, 2018); ABB, “ABB Unveils Ballistic Protection Solution for Power Transformers,” News release, November 19, 2015, <http://www.abb.com/cawp/seitp202/d2532be7107aab6085257f02005c6950.aspx>; Behr, Peter, “Substation Attack is New Evidence of Grid Vulnerability,” *E&E News*, October 6, 2016, <https://www.eenews.net/stories/1060043920>; Vanvig, John, “Transformer Shootings: ‘An Alarming Outbreak,’” *Rural Electric Magazine*, May 9, 2017, <http://remagazine.coop/transformer-shooting-electric-co-op-outbreak/> (accessed August 20, 2018).

²⁴ *Investigation No. 731-TA-1189 (Final): Large Power Transformers from Korea—Staff Report*, INV-KK-082, July 30, 2012, p. I-13.

Applications

LPTs are used to increase or decrease voltage in the electric transmission system. Power, as measured in volt-amperes,²⁵ is typically transmitted at a high voltage and low current (amperage) because transmission at higher amperages requires more cable, resulting in greater power losses and expense. Power is typically generated at less than 35 kilovolts (kV), increased (stepped up) for transmission to 69 to 765 kV, then decreased (stepped down) for distribution from 15 to 34.5 kV (figure I-7).²⁶ LPTs are the equipment in the electric power grid that increase or decrease these voltages.

Three common types of LPTs are step-up transformers, step-down transformers, and autotransformers. Generator step-up transformers increase voltage from electric power generation plants to high voltages for transmission through the electric grid (figure I-8). Step-down transformers are used at transmission substations to step down (decrease) voltages prior to distribution to consumers such as businesses and residences. Autotransformers connect transmission lines of different voltages. Some companies also produce mobile transformers, which are transportable and used to replace or augment stationary transformers for emergency service, routine maintenance, temporary power, substation capacity increases, and to meet seasonal demand.²⁷

²⁵ One MVA is equal to 1,000 kilovolt-amperes (kVA). One kVA is equal to 1,000 volt-amperes.

²⁶ Amperage is decreased when the voltage is stepped up and increased when the voltage is stepped down.

²⁷ Delta Star Website, <https://www.deltastar.com/mobile-transformers-substation> (accessed June 13, 2018).

Figure I-7
Examples of electric power transmission and distribution voltages

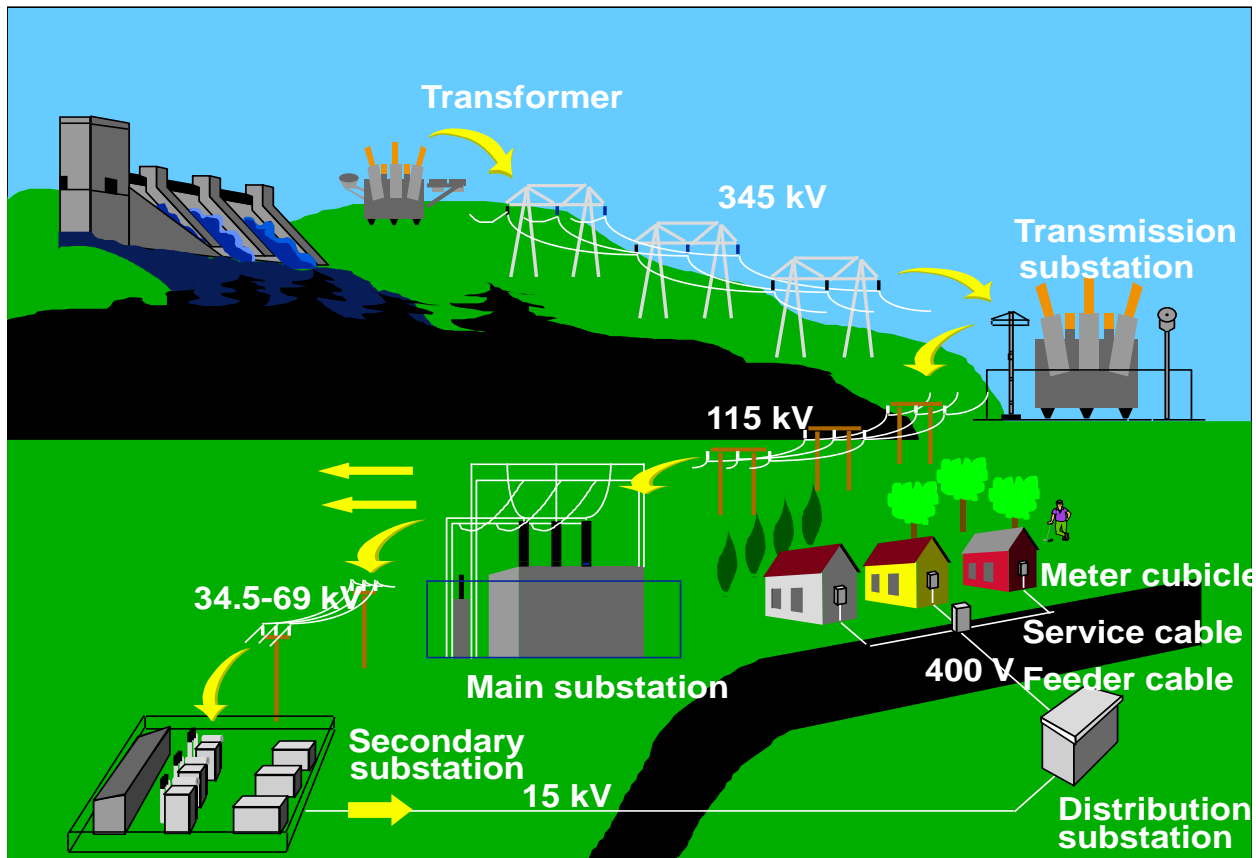

Source: *Large Power Transformers from Korea, Inv. No. 731-TA-1189 (Final)*, USITC Publication 4346, August 2012, p. I-6.

In the United States, more than half of electricity transmission circuit miles²⁸ were at 100 to 199 kV AC in 2016 (figure I-9). The second largest share of transmission circuit miles was at 200 to 299 kV AC (22 percent of circuit miles) and the third largest share at 300 to 399 kV AC (16 percent of circuit miles).²⁹

²⁸ A circuit mile is one “mile of either a set of AC three-phase conductors in an Overhead or Underground AC Circuit, or one pole of a DC Circuit. A one mile-long, AC Circuit tower line that carries two three-phase circuits (i.e., a double-circuit tower line) would equate to two Circuit Miles. A one mile-long, DC tower line that carries two DC poles would equate to two Circuit Miles. Also, a one mile-long, common-trenched, double-AC Circuit Underground duct bank that carries two three-phase circuits would equate to two Circuit Miles.” North American Electric Reliability Corporation (NERC), *Transmission Availability Data System (TADS) Definitions*, September 29, 2009, p. 3.

²⁹ NERC data are available for 100 to 799 kV AC and for DC transmission. U.S. Department of Energy (DOE), *Annual U.S. Transmission Data Review*, March 2018, p. 6, <https://www.energy.gov/sites/prod/files/2018/03/f49/2018%20Transmission%20Data%20Review%20FINAL.pdf>.

Figure I-8
Examples of step-up and step-down transformers in the electric grid

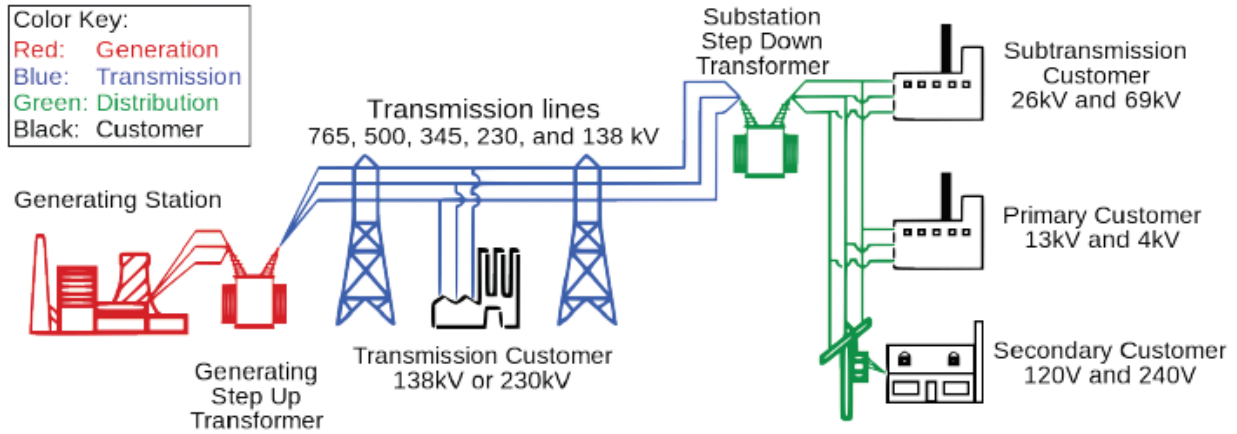

Source: U.S. Department of Energy, "Enabling Modernization of the Electric Power System." Chapter 3 in *Quadrennial Technology Review, An Assessment of Energy Technologies and Research Opportunities*, September 2015. <https://www.energy.gov/quadrennial-technology-review-2015>.

Figure I-9
Existing U.S. transmission, circuit miles, 2016, 100kV and above

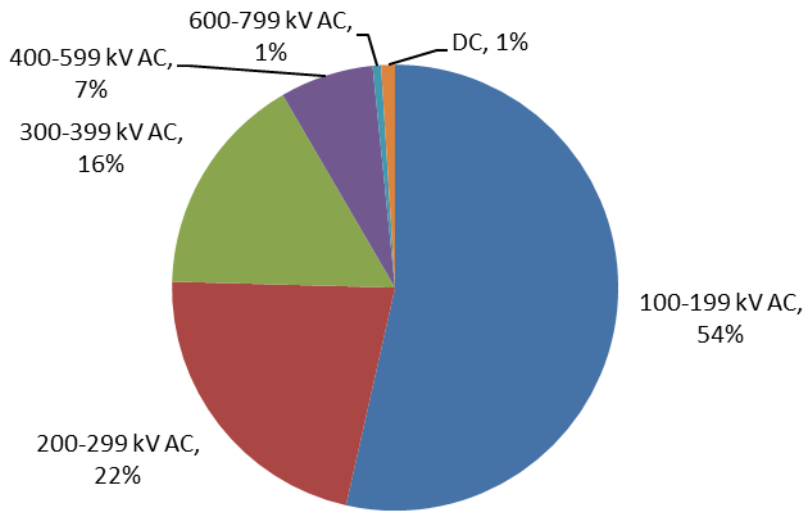

Source: NERC data cited in DOE, *Annual U.S. Transmission Data Review*, March 2018, p. 6, <https://www.energy.gov/sites/prod/files/2018/03/f49/2018%20Transmission%20Data%20Review%20FINAL.pdf>.

The users of LPTs include independent firms that generate electricity (independent power producers (“IPPs”)), electric utilities, and industrial customers. The users in the electric power industry, IPPs, and utilities, are defined below:

- **Independent power producer:** An IPP is an entity that primarily produces electricity for sale on the wholesale market. It is not a utility, does not own electricity transmission, and does not have a designated service area. IPPs may sign power purchase agreements (PPAs) with utilities. A PPA is a long-term agreement between a utility and an IPP to purchase electricity.
- **Electric utilities:**
 - **Investor-owned utility (“IOU”):** An IOU is a for-profit utility.
 - **Publicly owned utility (“POU”):** A POU is a nonprofit state or local government entity.
 - **Cooperative electric utilities:** Utilities that are owned by their members.
 - **Federal electric utilities:** Utilities that are owned by the U.S. government, such as the Tennessee Valley Authority (“TVA”).

Utilities accounted for 56 percent of cumulative U.S. utility-scale electric generating capacity as of the end of 2016, while IPPs accounted for 41 percent and commercial and industrial firms for 3 percent (figure I-10).³⁰ Among utilities, IOUs accounted for 62 percent of cumulative generating capacity as of 2013, POUs for 18 percent, federal utilities for 11 percent, and cooperatives for 9 percent. However, there are many more POUs and cooperative utilities than IOUs. In 2013, there were 2,013 POUs, 877 cooperative utilities, and 189 IOUs.³¹

³⁰ DOE, EIA, *Electric Power Annual*, December 7, 2017, table 4.4, https://www.eia.gov/electricity/annual/html/epa_04_04.html.

³¹ American Public Power Association data cited in Jun Makita, “A Comparative Study of Representative Electric Utility Companies Taking Community-based Strategy in the United Kingdom and the United States,” IEEJ, June 2017, p. 8, <https://eneken.ieej.or.jp/data/7381.pdf>.

Figure I-10
Existing generator nameplate capacity by producer type, 2016

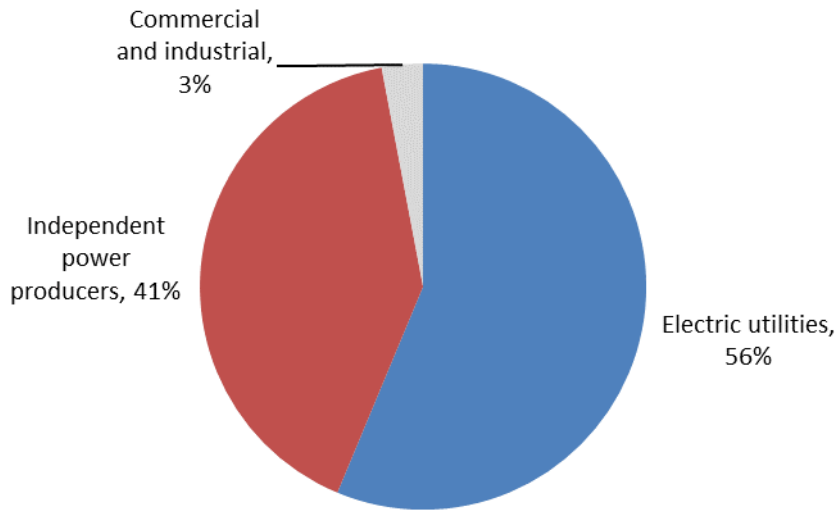

Source: DOE, EIA, Electric Power Annual, December 7, 2017, table 4.4, https://www.eia.gov/electricity/annual/html/epa_04_04.html.

Figure I-11
Share of utility generator nameplate capacity, by type of utility, 2013

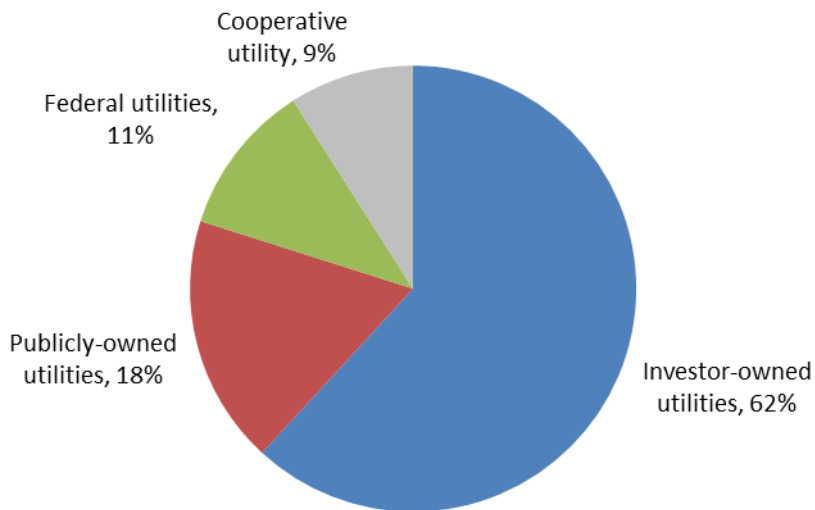

Source: American Public Power Association data cited in Jun Makita, "A Comparative Study of Representative Electric Utility Companies Taking Community-based Strategy in the United Kingdom and the United States," IEEJ, June 2017, p. 8, <https://eneken.ieej.or.jp/data/7381.pdf>.

IOUs and independent transmission companies are the largest owners of electricity transmission in the United States, accounting for 70 percent of transmission ownership (by miles of transmission lines owned) 230 kV or higher (figure I-12). Ownership of the rest of U.S. transmission is split among a number of entities, with federal utilities accounting for 14 percent of transmission 230 kV or higher, POUs for 7 percent, and cooperative utilities for 6 percent. For all transmission voltages, IOUs and transmission companies still own more than half of transmission. However, the share of all transmission owned by POUs and cooperatives is higher than for only 230 kV and above, while the share of all transmission owned by federal utilities is less than for only 230 kV or higher transmission.³²

Figure I-12
U.S. transmission ownership share, by miles of transmission, 230 kV or higher

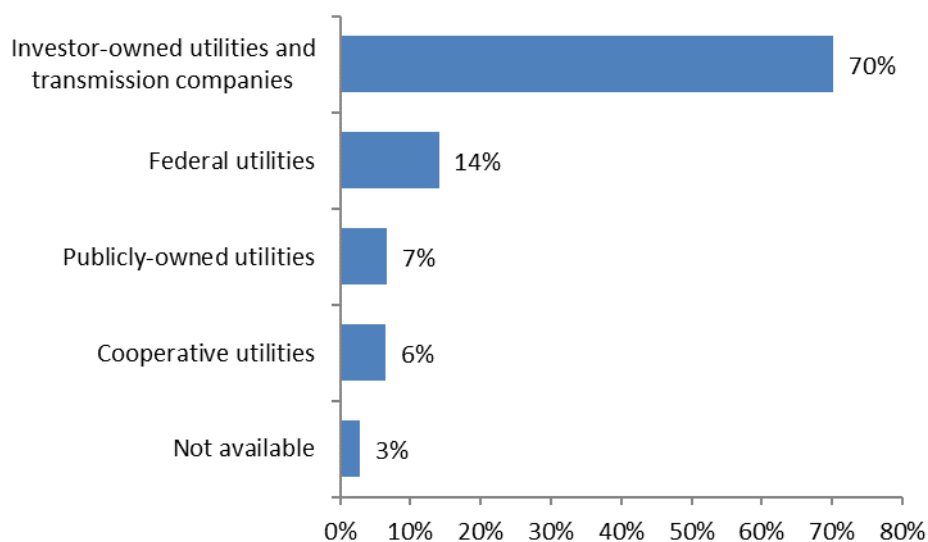

Notes: Ownership data are from an analysis for a 2009 Congressional Research Service (CRS) report. The CRS data do not include Alaska and Hawaii. Transmission companies are firms that only own transmission infrastructure.

Source: Stan Mark Kaplan, *Electric Power Transmission: Background and Policy Issues*, April 14, 2009, Congressional Research Service, p. 4, https://www.everycrsreport.com/files/20090414_R40511_ef62ebf281f43f4182e3a3d8c19478074d862d10.pdf.

³² Stan Mark Kaplan, *Electric Power Transmission: Background and Policy Issues*, April 14, 2009, Congressional Research Service, p. 4, https://www.everycrsreport.com/files/20090414_R40511_ef62ebf281f43f4182e3a3d8c19478074d862d10.pdf; Platts, “2015 UDI Directory of Electric Power Producers and Distributors,” *123rd Edition of the Electrical World Directory*, 2014, vi–vii, <https://www.platts.com/im.platts.content/downloads/udi/eppd/eppdir.pdf>.

Manufacturing processes³³

LPTs are large, made-to-order products that are manufactured to the individual specifications of the customer. Once a producer receives an order, the first step is designing the transformer. The design of LPTs is complex, with optimum transformer design balancing the costs of materials (e.g., steel, copper, and cooling oil), electrical losses, manufacturing labor hours, plant capability constraints, and shipping constraints, such as tunnel and bridge dimensions.

***.³⁴ LPT manufacturers work with customers starting with the design phase and continuing through the shipment and installation phases. Customers will ***³⁵ come to the plant to inspect the transformers. LPTs take months to design and build. ***.³⁶

Figure I-9
LPTs: Production process for core form transformers

* * * * *

***.³⁷

Tank fabrication

The tank (the exterior shell of the LPT) is a rectangular box-shaped fabrication made from hot-rolled, low carbon steel plates that are typically arc welded together. The tank has wall stiffeners, jack pads and lifting hooks, guides to fit the windings and core assembly inside, and a variety of access openings for maintenance. The interior is usually coated with epoxy and the exterior is painted.

The active part of the transformer

The manufacturing of the active part (the core, windings, and electrical insulation) consists of core cutting and assembly, winding, assembly of the active part, and vapor phase. The core is made of laminations of GOES shaped into the legs and yokes of the core. GOES is cut to shapes for the vertical sections of the core called limbs or legs, and the horizontal sections called the yoke. GOES parts are cut to shape by computerized shearing machines and these thin

³³ The discussion in this section focuses on core type transformers. Unless otherwise noted, this information is based on *Large Power Transformers from Korea, Inv. No. 731-TA-1189 (Final)*, USITC Publication 4346, August 2012, pp. I-10–12.

³⁴ *Investigation No. 731-TA-1189 (Final): Large Power Transformers from Korea—Staff Report*, INV-KK-082, July 30, 2012, p. I-14.

³⁵ *Ibid.*

³⁶ *Investigation No. 731-TA-1189 (Final): Large Power Transformers from Korea—Staff Report*, INV-KK-082, July 30, 2012, p. I-15.

³⁷ *Investigation No. 731-TA-1189 (Final): Large Power Transformers from Korea—Staff Report*, INV-KK-082, July 30, 2012, p. I-15.

strips are called laminations. These laminations are carefully stacked either by hand or machine to prevent damage to the electrical properties of the laminations. Bundles of like-shaped laminations are then bound together with epoxy polyester shrink tape to form either legs or yokes. The legs are then attached to the bottom yoke.

The windings are formed by winding an insulated copper wire conductor over a cylindrical framework, typically by hand. Spacers between various turns of conductors *** are inserted. Depending on the type of LPT being produced, different *** patterns of winding will be used. For certain transformers, this winding process can take weeks to complete.³⁸

The active part is then assembled by placing the windings over the legs. It is then cleaned, inspected, and put through a pressing operation. At this stage, the top yoke is added.

The windings and the core then undergo drying operations in a vapor phase drying chamber to remove moisture from the paper, pressboard, and spaces between the windings. In the chamber, solvent vapors condense on the windings and core, resulting in heating the article, and thus evaporating moisture out of the insulation. The vapor chamber is then flooded with transformer oil to impregnate the insulation materials. Once this is complete, the chamber is drained of oil and the assembly is removed.

LPT assembly

Once the active part is drained of oil, it is inspected and immediately moved to the tank. Then it is covered with oil and the cover is welded on. This oil is then drained, a vacuum is used to remove surface moisture, and the transformer is filled with degasified mineral oil for final impregnation. Other components such as the bushings are also added.

Testing

Testing is performed to ensure the accuracy of voltage ratios, verify power ratings, and determine electrical impedances. Testing is also performed to simulate certain events that may affect the LPT, including lightning strikes, short circuits, overvoltages (voltages in the circuit that are above the design limits), and accessories such as the cooling systems, indicators, and tap changers.

Shipping

Before an LPT is shipped, bushings, fans, the control cabinet, and other components are disassembled, the oil is removed, and the tank is filled with dry air. ***.³⁹

³⁸ *Investigation No. 731-TA-1189 (Final): Large Power Transformers from Korea—Staff Report*, INV-KK-082, July 30, 2012, p. I-16.

³⁹ *Investigation No. 731-TA-1189 (Final): Large Power Transformers from Korea—Staff Report*, INV-KK-082, July 30, 2012, p. I-17.

Manufacturing environment and production processes

The manufacturing environment and capability may significantly affect the LPT manufacturer's product reliability. LPT plants, particularly for the high voltage products, maintain almost clean room environments, especially in both windings and assembly areas; for example, dust particles will ruin an 800 kV LPT.

The operation and physical characteristics of an LPT manufacturing plant can affect whether a manufacturer is qualified by the customer to bid on a proposal or is recommended during the bid process. As part of the process of qualifying potential bidders, customers will visit LPT manufacturers, audit their production and quality processes, and verify their certifications and adherence to standards such as International Standards Organization standard 9001. Reportedly, it is important to have an advanced facility that shows well to customers, as it reflects efficient production, shorter lead times, and better delivery.

DOMESTIC LIKE PRODUCT ISSUES

In its original determinations, the Commission defined the domestic like product as a single domestic like product coextensive with the scope of the original investigation.⁴⁰ In its notice of institution in these current five-year reviews, the Commission solicited comments from interested parties regarding the appropriate domestic like product and domestic industry.⁴¹ According to their response to the notice of institution, the domestic interested parties agreed with the Commission's definition of the domestic like product as stated in the original investigation.⁴² The respondent interested party Hyundai Electric and Energy Systems stated in its response to the notice of institution that LPTs above 765kV should be treated as a separate domestic like product.⁴³ No party requested that the Commission collect data concerning possible domestic like products, including LPTs above 765kV, in their comments on the Commission's draft questionnaires, nor did any party comment on the possibility of multiple domestic like products in briefs or at the hearing.

⁴⁰ *Large Power Transformers from Korea, Inv. No. 731-TA-1189 (Final)*, USITC Publication 4346, August 2012, pp. I-12 to I-13. In the original investigation, respondents Hyosung Corporation and Hyundai Heavy Industries, Co. Ltd and Hyundai Corporation USA contended that the Commission should find two like products based on two separate categories. Category A included 60-300 MVA (top rated, standard step-up/step-down equivalent) power transformers for 345 kV high line system voltage, plus 60 MVA and above (top rated, standard step-up/step-down equivalent) power transformers for less than 345 kV high line system voltages; Category B included 60 MVA and above (top rated, standard step-up/step-down equivalent) power transformers for 500 kV and above high line system voltages, plus above 300 MVA (top rated, standard step-up/step-down equivalent) power transformers for 345 kV high line system voltage. *Ibid.*, pp. I-12 to I-13.

⁴¹ *Large Power Transformers from Korea; Institution of a Five-Year Review*, 82 FR 30896, July 3, 2017.

⁴² *Domestic Interested Parties' Response to the Notice of Institution*, August 2, 2017, p. 19.

⁴³ Hyundai did not provide any additional information. *Respondent Interested Party Hyundai's Response to the Notice of Institution*, August 2, 2017, p. 8.

U.S. MARKET PARTICIPANTS

U.S. producers

During the original investigation, five firms supplied the Commission with information on their U.S. operations with respect to LPTs. These firms accounted for virtually all U.S. production of LPTs during January 2009-March 2012.⁴⁴ In these current proceedings, the Commission issued U.S. producers' questionnaires to seven firms, all of which provided the Commission with information on their production operations. These firms are believed to account for the vast majority of U.S. production of LPTs in 2017. Presented in table I-5 is a list of current domestic producers of LPTs and each company's position on continuation of the order, production locations(s), and share of reported production of LPTs in 2017.

Table I-5
LPTs: U.S. producers, positions on order, U.S. production locations, and shares of 2017 reported U.S. production

Firm	Position on order	Production location(s)	Share of production (percent)
ABB	***	South Boston, Virginia; St Louis, MO	***
Delta Star	***	Lynchburg, VA San Carlos, CA	***
HYPO	***	Montgomery, AL	***
Mitsubishi	***	Memphis, TN	***
PTTI	***	Canonsburg, PA	***
SPX	***	Waukesha, WI	***
VA Transformer	***	Rincon, GA; Pocatello, ID	***
Total			100.0

Source: Compiled from data submitted in response to Commission questionnaires.

As indicated in table I-6, one U.S. producer (***) is related to a Korean LPT producer and is related to a U.S. importer of the subject merchandise. In addition, as noted in Part III, no U.S. producer directly imports the subject merchandise.

Table I-6
LPTs: U.S. producers' ownership, related and/or affiliated firms, since January 2012

* * * * *

⁴⁴ The five U.S. producers that supplied the Commission with usable questionnaire information during the original investigations were: ABB, Delta Star, Efacec, PTTI, and SPX. The Efacec plant was acquired by VA Transformer in 2015. Hearing transcript, p. 36 (Jain).

U.S. importers

In the original investigations, nine U.S. importing firms supplied the Commission with usable information on their operations involving the importation of LPTs, accounting for virtually all subject imports of LPTs.

In the current proceedings, the Commission issued U.S. importers' questionnaires to 30 firms believed to be importers of LPTs, as well as to all U.S. producers of LPTs. Usable questionnaire responses were received from ten firms, representing nearly all U.S. imports from Korea in 2017. Table I-7 lists all responding U.S. importers of LPTs from Korea and other sources, their locations, and their shares of U.S. imports in 2017.

Table I-7
LPTs: U.S. importers, headquarters, and shares of imports by source, 2017

Firm	Headquarters	Share of imports by source (percent)		
		Korea	Nonsubject sources	All import sources
ABB	Cary, NC	***	***	***
GE Prolec	Conover, NC	***	***	***
Hyosung	Seoul, KR	***	***	***
Hyundai Electric	Seoul, KR	***	***	***
Hyundai Corp	Torrance, CA	***	***	***
ILJIN Korea	Chungcheongnam-Do, KR	***	***	***
ILJIN USA	Houston, TX	***	***	***
LSIS	Seoul, KR	***	***	***
Siemens	Alpharetta, GA	***	***	***
Smit	Summerville, SC	***	***	***
Total		100.0	100.0	100.0

Source: Compiled from data submitted in response to Commission questionnaires.

U.S. purchasers

Purchasers include investor-owned utilities, public utilities, contractors (e.g., engineering and construction companies and project developers), and industrial users. The Commission received 25 questionnaire responses from firms that bought LPTs since January 1, 2012 (table I-8). Seventeen responding purchasers are investor-owned utilities ("IOUs"), five are public utilities ("POUs"), one is a distributor, two are engineering/construction company/power project developers ("EPCs"), and one ***.

Table I-8
LPTs: Purchasers, and quantity and value of purchases in 2017

* * * * *

APPARENT U.S. CONSUMPTION AND U.S. MARKET SHARES

Data concerning apparent U.S. consumption and U.S. market share of LPTs are shown in table I-9 and figure I-10. The quantity of U.S. producers' U.S. shipments declined during 2015-17 by *** percent after increasing slightly from 2015 to 2016. U.S. imports from nonsubject sources increased during 2015-17, ending *** percent higher in 2017 than 2015 after decreasing slightly in 2016. The quantity of U.S. imports from Korea increased by *** percent between 2015 and 2017. These trends resulted in an overall decrease in apparent U.S. consumption, ending *** percent lower in 2017 than in 2015, by quantity, after a *** in 2016. The value of apparent U.S. consumption also decreased, by *** percent, between 2015 and 2017. In terms of quantity and value, apparent U.S. consumption was *** percent and *** percent higher in January-March 2018 compared with January-March 2017, respectively. Both U.S. imports from nonsubject sources and U.S. producer's shipments were higher in January-March 2018 compared with January-March 2017.⁴⁵

⁴⁵ ***, which accounted for the largest share of the higher U.S. shipments, reported the increase was ***. Email from ***, June 6, 2018. ***, which accounted for the *** share of the higher U.S. shipments, noted that it ***. Email from ***, June 8, 2018.

Table I-9

LPTs: U.S. shipments of domestic product, U.S. imports, apparent U.S. consumption, and U.S. market shares, 2015-17, January to March 2017, and January to March 2018

Item	Calendar year			January to March	
	2015	2016	2017	2017	2018
	Quantity (MVA top rated)				
U.S. producers' U.S. shipments	***	***	***	***	***
U.S. importers' U.S. shipments of imports from.-- Korea	***	***	***	***	***
Nonsubject sources	***	***	***	***	***
All import sources	***	***	***	***	***
Apparent consumption	***	***	***	***	***
	Value (1,000 dollars)				
U.S. producers' U.S. shipments	***	***	***	***	***
U.S. importers' U.S. shipments of imports from.-- Korea	***	***	***	***	***
Nonsubject sources	***	***	***	***	***
All import sources	***	***	***	***	***
Apparent consumption	***	***	***	***	***
	Share of quantity (percent)				
U.S. producers' U.S. shipments	***	***	***	***	***
U.S. importers' U.S. shipments of imports from.-- Korea	***	***	***	***	***
Nonsubject sources	***	***	***	***	***
All import sources	***	***	***	***	***
	Share of value (percent)				
U.S. producers' U.S. shipments	***	***	***	***	***
U.S. importers' U.S. shipments of imports from.-- Korea	***	***	***	***	***
Nonsubject sources	***	***	***	***	***
All import sources	***	***	***	***	***

Note.--Shares and ratios shown as "0.0" represent values greater than zero, but less than "0.05" percent.

Source: Compiled from data provided in response to Commission questionnaires.

Figure I-10

LPTs: Apparent U.S. consumption, 2015-17, January to March 2017, and January to March 2018

* * * * *

Tables I-10 and I-11 and figures I-11 and I-12 present U.S. producers' and U.S. importers' U.S. shipments of 60 through 299 MVA top rated LPTs and of 300 and greater MVA top rated LPTs. LPTs of 300 and greater MVA top rated were the majority of apparent U.S. consumption. U.S. shipments of imports from nonsubject sources represented *** percent of U.S. shipments of LPTs of 300 and greater MVA top rated, followed by imports from Korea with roughly ***

percent of such shipments. While U.S. producers had the lowest share of the quantity of U.S. shipments of LPTs of 300 and greater MVA top rated, their shipments of such LPTs increased in each year during 2015-17, ending *** percent higher in 2017 than in 2015. In contrast, U.S. producers' U.S. shipments of LPTs of 60 through 299 MVA top rated, which was the largest source of this size LPTs in 2015, declined *** percent between 2015 and 2017. In 2017, U.S. shipments of imports from nonsubject sources became the largest source of U.S. shipments of LPTs of 60 through 299 MVA top rated.

Table I-10

LPTs: U.S. producers' and U.S. importers' U.S. shipments of 60 through 299 MVA top rated, 2015-17

* * * * *

Table I-11

LPTs: U.S. producers' and U.S. importers' U.S. shipments of 300 and greater MVA top rated, 2015-17

* * * * *

Figure I-11

LPTs: U.S. producers' and U.S. importers' U.S. shipments of 60 through 299 MVA top rated, 2015-17

* * * * *

Figure I-12

LPTs: U.S. producers' and U.S. importers' U.S. shipments of 300 and greater MVA top rated, 2015-17

* * * * *

PART II: CONDITIONS OF COMPETITION IN THE U.S. MARKET

U.S. MARKET CHARACTERISTICS

LPTs are components used in high voltage electrical power transmission systems to increase, transfer, or decrease the output voltages being transmitted. These expensive pieces of capital equipment typically cost millions of dollars and have a 15- to 40-year lifespan.

Each LPT is built to order for a purchaser's specific application and can vary in physical characteristics, power ratings, line voltages, and other characteristics. Purchasers request quotes from suppliers incorporating precise specifications. These are highly detailed documents requiring extensive preparation, and LPT producers invest a substantial amount of time reviewing the specifications, costing out the elements of design, and putting together a formal bid.¹ Suppliers typically provide transportation and installation services for LPTs.

The main purchasers of LPTs are electric utilities, including IOUs, POU, electrical cooperatives, and federally owned utilities. Other purchasers include electric, procurement, and construction companies ("EPCs"). IOUs account for the largest part of the U.S. LPT market. Hyosung estimates that IOUs constitute about 65 percent of sales in the LPT market, POU's make up about 15-20 percent, and other entities such as EPCs make up about 15-20 percent.² ABB estimates that IOUs account for *** percent of sales; POU, *** percent; cooperative-owned utilities, *** percent; and federally owned utilities *** percent.³

Some of the large IOUs have non-binding long-term alliance agreements⁴ with specific suppliers.⁵ Such alliance agreements typically last two to five years. Both U.S. producers and

¹ Open bids are more common with public utilities, while closed bidding is more common with private utilities and federally-owned utilities. *Large Power Transformers from Korea, Inv. No. 731-TA-1189 (Final)*, USITC Publication 4346, August 2012, p. II-1. Domestic interested parties' posthearing brief, exh. 1, p. 46.

U.S. producers stated that utilities require bid proposals to include almost a full design, including a loss evaluation based on the utility's detailed specifications (which can range from 2 to 300 pages), and that it can take 3 weeks to put together a proposal. Hearing transcript, pp. 106-107 (Blake), p. 107 (Newman).

² Hyosung stated that ***. Hyosung's posthearing brief, Responses to Commissioners' questions, pp. 1, 6.

³ Domestic interested parties' posthearing brief, exh. 1, p. 46.

⁴ These may be referred to as blanket agreements, alliance agreements, and framework agreements. Alliance agreements "ease the procurement process for duplicative orders of a similar transformer." Such agreements may include one to four suppliers. Typically, the LPT manufacturer will reserve space in their factory for their alliance agreement customers and provide a guaranteed lead time. The committed volume baseload allows the manufacturer to forecast its plant manning strategies for a period of time. Hearing transcript, pp. 65-66 (Mason).

⁵ Hyundai estimates that 10-15 percent of the LPT market is covered by alliance agreements. Hyundai's posthearing brief, Answers to Commissioner questions, p. 1. Among U.S. producers, firms' reported varying shares of their sales that are covered by alliance agreements: Delta Star (*** percent),
(continued...)

foreign producers participate in such agreements. The benefit for the utility is that once it buys one LPT with a specific design from a supplier, additional LPTs can be produced and shipped more rapidly. An advantage for suppliers is that they may have an increased chance of successful bidding over the duration of an agreement. Alliance agreements are increasingly awarded to more than one supplier.⁶

A number of firms reported changes in the product range of LPTs since January 1, 2012.⁷ Changes noted included increased demand for LPT functionalities that cater to environmental concerns, a transition from oil to alternative cooling fluids, increased demand from wind farms, and natural gas combined cycle generation step-up (“GSU”) transformers. One firm reported changes in LPT specifications resulting from growing demand for renewables and data centers as more customers are utilizing load tap changers (which enable the transformers to adjust for fluctuating load demands).

Anticipated changes reported include increased use of monitoring and metering equipment, utility scale solar “GSU” transformers, increasing costs for the development of LPTs that include functionalities that cater to environmental concerns, an expected increase in new technologies for condition monitoring and grid resiliency, and customers’ development of spare LPT storage programs to respond to outages caused by catastrophic events.

Domestic interested parties state that the use of monitoring devices has allowed utilities to keep LPTs in use for longer time periods rather than replacing them at a set time.⁸ Hyosung stated that the rise in digital monitoring systems has not decreased demand for LPTs.⁹

Overall, apparent U.S. consumption in 2017 was 1.3 percent lower than in 2015, and was 27.8 percent higher in first quarter 2018 than in first quarter 2017.

CHANNELS OF DISTRIBUTION

Most LPTs are sold to electric utilities (table II-1). *** of U.S. producers’ sales were to utilities during 2015-17. Two U.S. producers also reported sales to other end users. Specifically, *** reported sales to electric cooperatives and *** reported sales to EPCs. Imports from Korea were shipped primarily to distributors and utilities, with the share going to distributors increasing from 2015 to 2017. ***. Most imports from nonsubject countries were sold to utilities.

(...continued)

ABB (***) percent), SPX (***) percent), PTTI (***) percent), VA Transformer (***) percent). Domestic interested parties’ posthearing brief, exh. 1, p. 20.

⁶ Domestic interested parties’ prehearing brief, p. 26.

⁷ Four of 7 U.S. producers and 5 of 10 importers reported changes in product range or product mix, and 3 U.S. producers and 5 importers anticipate further changes.

⁸ Domestic interested parties’ posthearing brief, exh. 1, p. 48.

⁹ Respondent interested party Hyosung’s posthearing brief, Responses to Commissioners’ questions, p. 2.

Table II-1

LPTs: U.S. producers' and importers' share of the quantity of reported U.S. commercial shipments, by sources and channels of distribution, 2015-17, January-March 2017, and January-March 2018

* * * * *

GEOGRAPHIC DISTRIBUTION

U.S. producers and importers of Korean product reported selling LPTs to all regions in the contiguous United States (table II-2). For U.S. producers, *** percent of sales were within 100 miles of their production facility, *** percent were between 101 and 1,000 miles, and *** percent were over 1,000 miles. Importers of Korean LPTs sold *** percent within 100 miles of their U.S. point of shipment, *** percent between 101 and 1,000 miles, and *** percent over 1,000 miles.

Table II-2

LPTs: Geographic market areas in the United States served by U.S. producers and importers

Region	U.S. producers	Importers
Northeast	6	5
Midwest	7	7
Southeast	7	3
Central Southwest	7	4
Mountain	4	4
Pacific Coast	5	4
Other ¹	1	---
All regions (except Other)	4	2
Reporting firms	7	7

¹ All other U.S. markets, including AK, HI, PR, and VI.

Source: Compiled from data submitted in response to Commission questionnaires.

SUPPLY AND DEMAND CONSIDERATIONS

U.S. supply

Table II-3 provides a summary of the supply factors regarding LPTs from U.S. producers and from Korea. As can be seen in the table, Korean capacity was more than twice the capacity of U.S. producers. In addition, Korean producers shipped LPTs mostly to export markets whereas U.S. producers had very few exports.

Table II-3

LPTs: Supply factors that affect the ability to increase shipments to the U.S. market

Country	Capacity ¹ (1,000 MVA top rated)		Capacity utilization ¹ (percent)		Ratio of inventories to total shipments (percent)		Shipments by market, 2017 (percent)		Able to shift to alternate products
	2015	2017	2015	2017	2015	2017	Home market shipments	Exports to non-U.S. markets	No. of firms reporting “yes”
United States	***	***	***	***	***	***	***	***	***
Korea	178	171	78.8	71.6	2.6	2.7	***	***	2 of 4

¹ Capacity and capacity utilization presented in this table are based on LPTs only. Overall capacity and capacity utilization for LPTs and other products produced using the same equipment are presented in Part III and Part IV.

Note.--Responding U.S. producers accounted for all of U.S. production of LPTs in 2017. Responding foreign producer/exporter firms accounted for all of U.S. imports of LPTs from Korea during 2017. For additional data on the number of responding firms and their share of U.S. production and of U.S. imports from Korea, please refer to Part I, “Summary Data and Data Sources.”

Source: Compiled from data submitted in response to Commission questionnaires.

Domestic production

Based on available information, U.S. producers of LPTs have the ability to respond to changes in demand with large changes in the quantity of shipments of U.S.-produced LPTs to the U.S. market. The main contributing factors to this degree of responsiveness of supply are the availability of unused capacity and the ability to shift production to or from alternate products. Factors mitigating responsiveness of supply include limited ability to shift shipments from alternate markets and limited inventories.¹⁰

U.S. production capacity increased while production decreased from 2015 to 2017. Exports accounted for a very small share of U.S. producer shipments, with five U.S. producers reporting no exports and two firms reporting exports to ***. U.S. producers reported that export constraints include the fact that they do not currently export LPTs, and the existence of tariff and nontariff measures in other countries. U.S. producer *** reported that U.S. exports face tariffs in China (10 percent), the EU (3.7 percent), India (7.5 percent), and Korea (8 percent).¹¹ U.S. producers may have some ability to shift production to and from other products since they also produce transformers rated lower than 60 MVA. Production of these out-of-scope transformers accounted for *** percent of total production on the same equipment in 2017.

¹⁰ Given the customer-specific design and engineering specifications for LPTs, producers do not normally hold inventories.

¹¹ However, Hyosung notes that under the Korea-U.S. Free Trade Agreement, normal customs duty rates on U.S. exports of LPTs to Korea are zero. Hyosung’s posthearing brief, Responses to Commissioners’ questions, p. 4.

When asked about changes in the availability of domestic supply since January 1, 2012, many firms reported expanded U.S. production of LPTs. Multiple firms reported the opening or expansion of new U.S. plants including those of SPX (Waukesha, Wisconsin), HYPO (Montgomery, Alabama), and Mitsubishi (Memphis, Tennessee); VA Transformer's purchase of Efacec's plant in Georgia; and the closure of ABB's plant in Missouri and the shift to its Boston factory. Purchasers also reported an expansion in domestic production capabilities (including Mitsubishi's new factory which can produce 500 and 765 kV LPTs, and SPX's broadened production in Wisconsin to 345 kV LPTs), increased lead times, and increased demand that has led to decreased availability.

In terms of changes in anticipated U.S. supply, two U.S. producers (***) expect decreases in U.S. production of LPTs because of decreased capacity and flat demand for LPTs. On the other hand, *** anticipates continued increases in U.S. capacity and more availability of U.S.-produced LPTs ***.

Among purchasers, *** expect continued growth of U.S. manufacturing capacity. *** stated that new U.S. plants such as Mitsubishi and HYPO are not yet at full capacity and full capability, and that it takes time for new facilities to ramp up production (partly because it is difficult to retain skilled labor). *** stated that the new Mitsubishi factory appears to be producing higher-quality LPTs that are large enough for its use. *** anticipates more availability of domestic LPTs and stated that utilities are starting to realize the benefits of buying domestic LPTs, including lower shipping costs and shorter lead times.

Subject imports from Korea

Based on available information, Korean producers have the ability to respond to changes in demand with large changes in the quantity of shipments of LPTs to the U.S. market. The main contributing factors to this degree of responsiveness of supply are the availability of unused capacity and ability to shift shipments from alternate markets. Factors mitigating responsiveness of supply include limited inventories and limited ability to shift production to or from alternate products.

Korean producers' capacity declined from 2015 to 2017, as did their production. Three Korean producers reported producing power transformers rated below 60 MVA using the same equipment as LPTs; *** also reported producing reactors and gas-insulated transformers. Production of these other products comprised a small portion of total production on the machinery (**% percent in 2017).

The share of shipments to the Korean home market declined irregularly from 2015 to 2017. Korean producers reported exporting LPTs to a variety of markets including the Middle East, Asia, the EU, and Canada, but reported that it would be difficult to shift sales between the U.S. market and other markets. *** explained that shifting between markets depends on its ability to meet each customer's specific needs for LPTs, which are complex, custom-made products. *** stated that shifting between markets would take considerable time and effort because of the customized nature of LPTs which requires costly and time consuming pre-qualification by customers. *** stated that one year would be a short time to be able to sell into a new market because of the initial technical and commercial investment required and since end users request a producer's supply record. *** stated that it would take at least a

decade to shift LPTs sales to the U.S. market because of needed proof of quality and product performance, and that it takes years to build trust with customers.

Three of the four Korean producers reported that the product range, product mix, or marketing is different in the Korean home market than in export markets. *** stated that technical standards and requirements vary in each market, but that it is trying to expand its sales to LPTs of 300 MVA top rated or greater despite its current focus on LPTs with voltages of 100 kV or higher and capacities of 60 MVA, since fewer facilities can manufacture these sizes. *** stated that in Korea, its salesperson directly contacts the customer and performs marketing and promotion activities, whereas in export markets, independent sales agents provide marketing intelligence. *** stated that since LPTs are made to meet specific system requirements, each LPT has its own design and marketing strategy.

Korean producers reported several changes in factors affecting supply since 2012, including increased labor, energy, and shipping costs in Korea. Firms stated that the 2017 bankruptcy of Hanjin Shipping Co., the largest shipping company in Korea, has led to transport and logistics disruptions.

Korean producers reported that they do not face import competition in their home market. *** stated that it does not face import competition in the Korean public sector market, where bidding is limited to Korean producers, and that even in the private sector it is difficult for foreign producers to compete because of stringent requirements. It also stated that foreign producers lack interest in the Korean market because of the small market size.

Several purchasers reported changes in the availability of LPTs from Korea. *** reported lower availability. *** stated that Korean plants have focused on shunt reactors and small power and have been reluctant to compete on price. *** stated that tariffs exceeded the competitive pricing required to maintain market share. ***.

Imports from nonsubject sources

Nonsubject imports accounted for *** percent of total U.S. imports in 2017. Major sources of nonsubject imports during 2017 include Austria, the Netherlands, and Mexico.

When asked about changes in the availability of nonsubject imports since 2012, firms reported increased imports from a variety of countries including Brazil, China, Croatia, India, Taiwan, and Turkey. One importer stated that imports from China and Mexico have increased because they are priced lower than LPTs produced in the United States and Korea. One purchaser stated that although Chinese manufacturers have tried to enter the U.S. market, it is a very tough market to penetrate. Hyosung stated that Chinese producers sell mainly to public utilities in the United States, a market in which it does not compete.¹²

¹² Hyosung's posthearing brief, Responses to Commissioners' questions, p. 5.

Supply constraints

The vast majority of responding firms (all 7 U.S. producers, all 10 importers, and 22 of 25 purchasers) reported no supply constraints for LPTs since January 1, 2012. Three purchasers reported that a firm had refused, declined, or been unable to supply LPTs. *** reported a delay with a 300 MVA phase shifting transformer, and stated that if manufacturers decline to bid regularly or if there are not enough bidders, it looks for other suppliers. *** reported supply constraints for certain size LPTs (500 kV/433 MVA and 230 kV/300 MVA). It stated that *** could not comply with its terms and conditions but appeared to offer a product at 230 kV/ 300 MVA and that the 500 kV suppliers in the United States are “severely limited.” *** stated that occasionally firms choose not to bid without explanation, and that it maintains a pool of qualified bidders to increase the number of bids.

New suppliers

Ten of 25 purchasers indicated that new suppliers have entered the U.S. market since January 1, 2012, and 10 expect additional entrants. Purchasers cited Hyundai’s and Mitsubishi’s new U.S. factories and VA Transformer’s purchase of the Efacec plant in Georgia. Other noted new and anticipated suppliers include: WEG (Brazil), PTI (Canada), Chint Electric (China), TBEA (China), Koncar (Croatia), JST (France), CG Power (India), VRT Power (Israel), ILJIN (Korea), GE Prolec (Mexico), Efacec (Portugal), Smit (Netherlands), and Fortune Electric (Taiwan). One purchaser stated that JST may partner with Georgia Transformer to increase its U.S. presence and that other suppliers will also likely try to expand their presence in the U.S. market due to the age of the U.S. installed base.

U.S. demand

Based on available information, the overall demand for LPTs is likely to experience small changes in response to changes in price. The main contributing factors are the lack of substitute products and the small cost share of LPTs in its end-use products.

Annual total net electricity generation at utility scale facilities has been relatively steady from 2012 to 2017 (figure II-1). Domestic and respondent interested parties cite long-term projections of U.S. electricity demand at an annual average rate of 0.8 to 0.9 percent.¹³ Industrial construction and housing starts affect electricity demand. Housing starts increased during each year from 2012 to 2017, with larger percentage increases earlier in the period - 2013 (18 percent), 2014 (8 percent), and 2015 (11 percent) - than during 2016 (6 percent) and

¹³ Domestic parties cite an Edison Electric Institute projection that U.S. demand for electricity will increase at an annual average rate of 0.8 percent from 2017 to 2040. Domestic interested parties’ prehearing brief, exh. 1, p. 29. Respondent interested party Hyundai cites an EIA estimate of average annual growth of 0.9 percent from 2017 to 2050. Hyundai’s prehearing brief, p. 12.

2017 (2 percent).¹⁴ For industrial construction, respondent Hyundai cites the AIA consensus forecast, the latest of which presents a forecast of a 0.1 percent decline in 2018, and a 4.9 percent increase in 2019.¹⁵

Figure II-1
Total net electricity generation at utility scale facilities, by sector, 2012-17

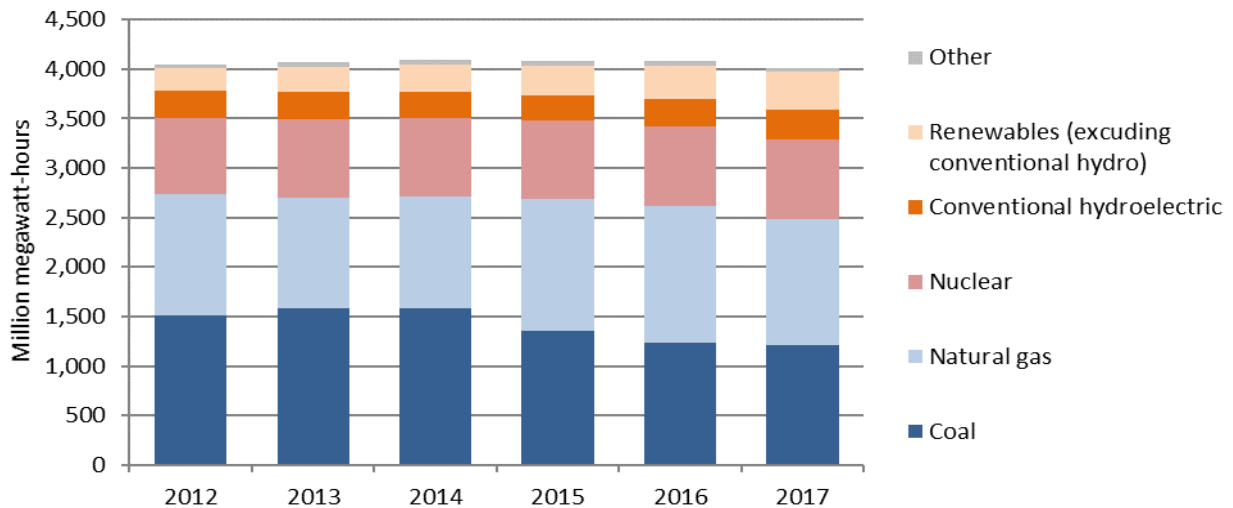

Source: U.S. Department of Energy, Energy Information Administration, "Electric Power Monthly, Data for March 2018," May 24, 2018, <https://www.eia.gov/electricity/monthly/>.

LPT demand is driven by the need to replace aging infrastructure, and by the construction of new generation facilities and transmission lines. New utility-scale power plant additions varied during each year of 2012 to 2017. They declined from 28.8 GW in 2012 to 14.1 GW in 2013, increased to 17.1 GW in 2014 and 17.9 GW in 2015, and then increased to 27.7 GW in 2016 before falling somewhat to 20.1 GW in 2017 (figure II-2). The largest increases in newly installed electricity generation came from new solar, wind, and natural gas generation capacity. Investment in transmission by investor-owned utilities increased from \$14.8 billion in 2012 to \$20.8 billion in 2016 and was projected to total \$22.9 billion in 2017 (figure II-3).

¹⁴ Privately-owned housing units, in thousand units, were 781 in 2012, 925 in 2013, 1,003 in 2014, 1,112 in 2015, 1,174 in 2016, and 1,203 in 2017. Housing starts were 8 percent higher in the first half of 2018 than in the first half of 2017. U.S. Census Bureau website, <https://www.census.gov/construction/nrc/index.html>, July 18, 2018.

¹⁵ "Despite emerging economic concerns, construction spending projected to grow," July 20, 2018, American Institute of Architects' website, <https://www.aia.org/articles/205181-despite-emerging-economic-concerns-construc>. Hyundai's prehearing brief, p. 12, presents data for AIA's January forecast.

Figure II-2
U.S. utility-scale net summer capacity additions, retirements, and changes, by energy source, 2012-17

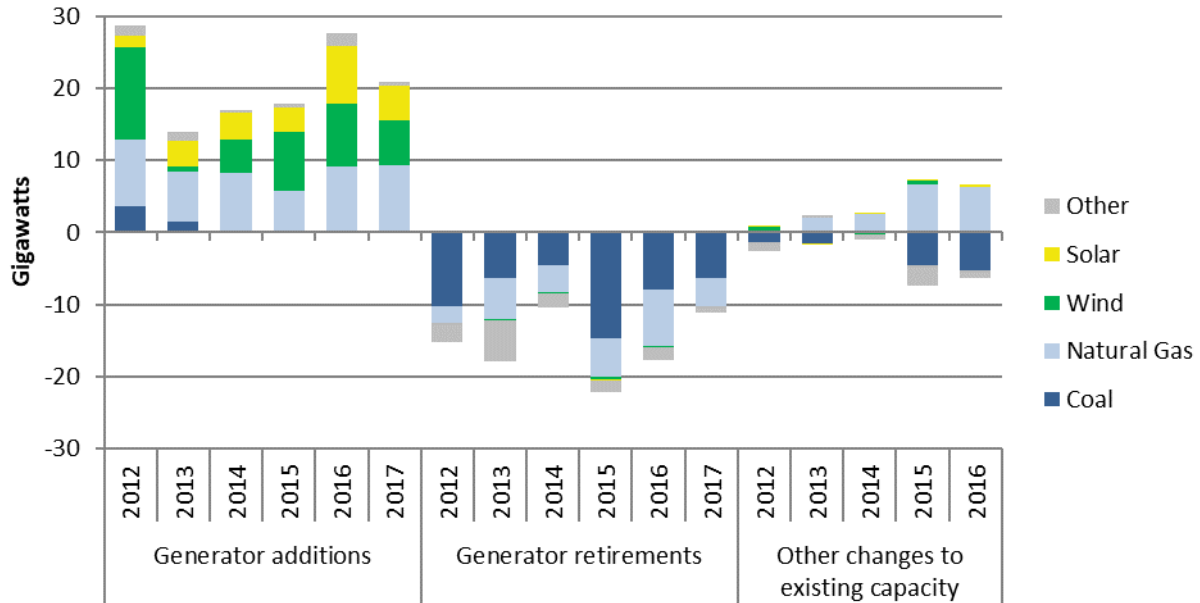

Note.--Other changes to existing capacity "reflect updates, derates, repowerings, and changes to previously reported generator capacity." Data on changes to existing capacity for 2017 are not available.

Source: EIA, Electric Power Annual 2012-16, Table 4.6, <https://www.eia.gov/electricity/annual/>; EIA, Electric Power Monthly, Tables 6.3 and 6.4, February 2018, <https://www.eia.gov/electricity/monthly/>.

Figure II-3
Investment in transmission by investor-owned utilities, 2012-16 and projected 2017

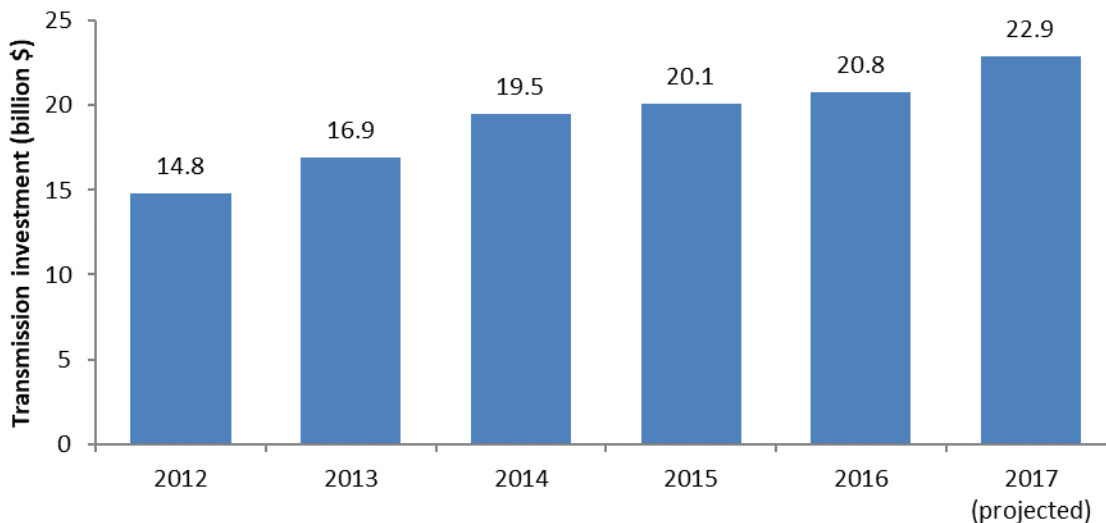

Source: U.S. Department of Energy, Annual U.S. Transmission Data Review, March 2018, p. 11, <https://www.energy.gov/sites/prod/files/2018/03/f49/2018%20Transmission%20Data%20Review%20FINAL.pdf>; Edison Electric Institute website, <http://www.eei.org/resourcesandmedia/industrydataanalysis/industrydata/Pages/default.aspx#transmission> (accessed June 14, 2018).

End uses and cost share

The end use for LPTs is electricity generation. Most firms (all 7 responding U.S. producers, 8 of 10 importers, and 21 of 23 purchasers) reported no changes in end uses since January 1, 2012. Most firms (all 7 producers, 8 of 10 importers, and 22 of 23 purchasers) also anticipate no changes in end uses. Importer *** reported a large increase in the number of smaller, wind-farm generator transformers. It expects the future electrical grid to be more decentralized, which will reduce the average size, and increase the quantity, of new power transformers. Purchaser *** stated that the utility business is expected to continue to experience load growth of 1.5 to 2 percent per year.

LPTs account for a small-to-moderate share of the cost of substations and a small share of the total cost of electricity generation and distribution. Purchaser *** reported that the cost of LPTs represents less than 1 percent of the total cost of producing energy. Purchasers' reported cost shares for substations and wind farms were as follows:

- Distribution substations: 10-37 percent (most firms reported 20-30 percent)
- Generating facility substations: 1-40 percent (4 firms reported 1-2 percent, and 1 firm each reported 10, 20, and 40 percent)
- Transmission line substations: 10-40 percent (most firms reported 10-20 percent)
- Wind farms: 1-2 percent

Business cycles

Most firms (6 of 7 U.S. producers, 8 of 10 importers, and 17 of 22 purchasers) indicated that the market was not subject to business cycles. U.S. producer *** stated that LPT sales have traditionally lagged housing starts and the distribution transformer market by 18 months. Importer *** stated that there are long-term business cycles and trends based on replacement demand, expansion of power grids, and the mix of power generation sources. Importer *** stated that business is seasonal based on when installations occur. Purchasers ***. Purchaser *** stated that utility industry regulations can affect the business cycle.

Some firms (2 of 7 U.S. producers, 5 of 10 importers, and 3 of 22 purchasers) indicated that the market was subject to other distinct conditions of competition. U.S. producer *** stated that Section 232 steel tariffs will increase costs for domestic LPT manufacturers.¹⁶ Among importers, *** stated that IOUs generally purchase from their primary suppliers until these plants' lead times move out beyond one year, and then these utilities will purchase from

¹⁶ Section 232 steel tariffs are discussed in Part V.

“second tier” suppliers with more competitive lead times. *** reported changes in energy and environmental regulations and electrical grid operations; changes in generation fuels (such as from coal to gas); and changes in long-term electrical demand and planning (citing changing climate, utility rate decisions, customer mergers, and technology changes, such as CFC and LED lighting and growth of consumer electronics). *** stated that the market for LPTs rated above 100 MVA is expected to experience substantial growth due to new renewable generation installations and the replacement of aging power grid infrastructure.

Among purchasers, *** reported market segmentation and regionalization based on industry restructuring, mergers, and acquisitions. *** stated that there are a limited number of technically qualified LPT suppliers, many of which are located outside of the United States. *** stated that there were no good domestic 500 kV options until 2014, and that the new suppliers have had problems.¹⁷

In regards to changes in conditions of competition, U.S. producer *** stated that since 2014, a large increase in low-priced Korean LPT imports has driven down market prices. Importer *** stated that LPT demand has gradually increased because of the replacement of aging transformers and the development of solar and wind energy. Importer *** stated that global overcapacity has led to downward pressure on prices. Purchasers reported changes in domestic production, including new U.S. factories and a factory closure.

Demand trends

Firms’ responses varied regarding changes in U.S. demand for LPTs since January 1, 2012 (table II-4). Most firms expect U.S. demand for LPTs to increase, not change, or fluctuate over the next two years; no firm reported that it expects demand to decrease.

U.S. producer *** reported decreased demand for LPTs since 2015, and *** reported that demand has been relatively flat since 2012. U.S. importers *** reported increased demand and attributed the increase to the overall growth of power consumption, an increasing number of replacement projects and transmission line extension projects, and construction of new plants. *** stated that although demand has fluctuated with oil prices, there has been an overall decrease in demand since 2012.

Most purchasers (19 of 24) reported that their firm’s demand for LPTs had not changed since January 1, 2012 due to a change in the rate of replacement of aging transformers. Several firms reported an increased rate of replacement since 2012, including ***, which stated that its asset replacement program was completed in 2017, and ***, which reported that the majority of its demand in 2017 was for spare and replacement LPTs.

¹⁷ ***.

Table II-4
LPTs: Firms' responses regarding U.S. demand since January 1, 2012

Item	Number of firms reporting			
	Increase	No change	Decrease	Fluctuate
Demand in the United States:				
U.S. producers	***	***	***	***
Importers	***	***	***	***
Purchasers	8	4	2	6
Foreign producers	2	---	2	---
Anticipated future demand in the United States:				
U.S. producers	***	***	---	***
Importers	***	***	---	***
Purchasers	9	4	---	7
Foreign producers	4	---	---	---
Demand for purchasers' final products:				
Purchasers	4	7	4	8

Source: Compiled from data submitted in response to Commission questionnaires.

A minority of firms (2 of 7 U.S. producers, 4 of 10 importers, and none of the 24 responding purchasers) reported that smart grid technology had impacted their sales or purchases of LPTs. U.S. producers *** stated that smart grid technology will decrease demand for large-sized LPTs, with *** stating that demand will increase for smaller, more efficiently designed, more nimble transformers used for more reliable power transmissions over short distances. Importer *** stated that some IOU's increased capital funding for smart grid has reduced their funding for transmission equipment.

Many firms (4 of 7 U.S. producers, 7 of 10 importers, and 11 of 24 purchasers) reported that growth in renewable energy affected their sales or purchases of LPTs since January 1, 2012. Most of the purchasers reported increased demand because of increased solar and wind power generation. Purchaser *** reported a spike in demand from 2009 to 2015 from wind suppliers, which ended when California changed its regulation regarding renewable energy sources. Importer *** stated that many renewable projects are procured by EPCs which tend to buy lower-quality, lower-priced transformers. Importer *** stated that its product mix to the North American market has changed since renewable energy applications use smaller-sized transformers. U.S. producer *** reported that electric grid reconfiguration to connect renewables has offset some of the loss of larger LPTs used in now-closed coal generating stations. U.S. producer *** reported that the growth in renewable energy has increased its sales and production. U.S. producer *** stated that decreased demand for traditional GSU transformers at coal and nuclear generating stations has been partially offset by an increase in large autotransformers associated with renewables connecting to the transmission grid.

Increased investment in natural gas and renewable energy installations in place of large coal and nuclear facilities has shifted demand to smaller-sized LPTs and medium power

transformers.¹⁸ These renewable energy installations may require a larger number of units than those utilizing the larger sized transformers. Domestic producers stated that demand for LPTs is driven more by replacement needs than new electricity generation, although the increased use of monitoring equipment has extended the life of LPTs and decreased replacement rates.¹⁹

SUBSTITUTABILITY ISSUES

The degree of substitution between domestic and imported LPTs depends upon such factors as relative prices, quality (e.g., load losses, engineering capabilities, ability to meet customer specifications, etc.), and conditions of sale (e.g., lead times, warranties, reliability of supply, product services, etc.). Based on available data, staff believes that there is a moderate-to-high degree of substitutability between domestically produced LPTs and LPTs imported from Korea.

Lead times

LPTs are produced-to-order. U.S. producers' reported lead times ranged from 160 to 490 days, and averaged 323 days. Importers' reported lead times were similar, ranging from 148 to 434 days, and averaging 300 days.

Knowledge of country sources

Twenty-four purchasers indicated they had marketing/pricing knowledge of domestic LPTs, 18 of Korean LPTs, and 25 of LPTs from nonsubject countries.

As shown in table II-5, most purchasers "sometimes" or "never" make purchasing decisions based on the producer or country of origin. Of the eight purchasers that reported that they always make decisions based on the manufacturer, most reported the need for manufacturer qualification.²⁰ *** stated that smaller LPTs are available from "quality" U.S. suppliers, but for larger LPTs, it usually considers foreign suppliers because of quality and long-term expertise in producing larger units. It added that there are two U.S. factories that have begun producing larger LPTs: ***.

¹⁸ Wind and solar farms are reportedly purchasing 90 to 100 MVA units rather than the 200 to 500 MVA LPTs purchased by coal plants. Hearing transcript, pp. 62, 73 (Mason), p. 164 (Kang).

¹⁹ Hearing transcript, p. 61 (Mason), pp. 63-65 (Newman, Mason, Robinson).

²⁰ ***.

Table II-5**LPTs: Purchasing decisions based on producer and country of origin**

Purchaser/customer decision	Always	Usually	Sometimes	Never
Purchaser makes decision based on producer	8	3	6	8
Purchaser makes decision based on country	2	1	10	12

Source: Compiled from data submitted in response to Commission questionnaires.

Factors affecting purchasing decisions

The most often cited top three factors firms consider in their purchasing decisions for LPTs were quality (18 firms), price (16 firms), and lead time/delivery (11 firms) as shown in table II-6. Quality was the most frequently cited first-most important factor (cited by 9 firms), followed by meets specification/qualification (6 firms); price was the most frequently reported second-most important factor (10 firms); and quality and price were the most frequently reported third-most important factor (5 firms each).

Table II-6**LPTs: Ranking of factors used in purchasing decisions as reported by U.S. purchasers, by factor**

Factor	First	Second	Third	Total
Quality	9	4	5	18
Price	1	10	5	16
Lead time/delivery	2	5	4	11
Meet specification/qualification	6	---	---	6
Design/technical expertise	4	1	---	5
Total cost of ownership/evaluated cost	1	1	2	4
Availability	---	1	3	4
Unit efficiency	---	---	2	2
Other ¹	4	3	4	11

¹ Other factors include range of product line, reliability, failure rate and R&D capabilities, and traditional supplier for first factor; cost-competitiveness after taking into account evaluated losses, country of origin (U.S. only), and historic performance for second factor; capabilities, warranty, and history of support for third factor.

Source: Compiled from data submitted in response to Commission questionnaires.

Eleven of 25 purchasers reported that they “usually” purchase the lowest-priced product, 10 “sometimes”, 3 “never,” and 1 “always.”

Most purchasers (17 of 24) indicated that they do not order LPTs from any one particular country over other possible sources of supply. Of the seven firms that indicated a preference, most noted a preference for domestic LPTs. *** explained that it prefers North American suppliers because it is easier to obtain warranty work if the LPT fails, and that U.S. suppliers have better quality assurance and quality control. *** prefers domestic suppliers if a quality supplier is available for a given size and voltage class, but that for 500 kV units, the only reliable, quality suppliers were overseas for most of the review period. *** stated that it prefers to be able to visit production facilities to assess quality, and that delivery logistics are important. *** does not order LPTs from “developing countries” such as China or Brazil.

Most purchasers (17 of 25) indicated that there were not certain types, capacities, or sizes of LPTs that were only available from certain country sources. Among the firms that reported some limitations in availability of certain types of LPTs, three purchasers indicated that phase shifter transformers are not produced domestically, with *** stating that these products are available only from Germany and the Netherlands. *** stated that 500 kV winding substation transformers are not adequately available from domestic producers. *** reported that each country has different available MVA ranges and that there are fewer suppliers for higher MVA ratings. *** stated that U.S. manufacturing is generally restricted to 345 kV and lower MVA ratings, explaining that only Mitsubishi offers 765 kV with no limitations, that SPX is limited to 345 kV/400 MVA, that HYPO is not up to 500 kV, and that VA Transformer is restricted to 345 kV and ***. *** reported some limited availability of larger LPTs.²¹

Importance of specified purchase factors

Purchasers were asked to rate the importance of 24 factors in their LPT purchasing decisions (table II-7). The factors rated as very important by more than half of responding purchasers were quality meets industry standards (23 purchasers); delivery time, reliability of supply, technical support/service, and warranties (22 each); availability, price, and product consistency (21 each); evaluated cost and responsiveness of supplier (20 each); energy loss (18); delivery terms (16); long-term relationship and time to fill order (15 each). Factors rated as not important by a majority of firms were extension of credit (15) and minimum quantity requirements (16).

Supplier certification

Most responding purchasers (21 of 25) require their suppliers become certified or qualified to sell LPTs to their firm.²² Purchasers reported varying times to qualify a new supplier: six firms reported 90 days or fewer, seven firms reported up to one year, and three firms reported over one year.²³

The certification process may include the approval of a qualified design, and an examination of product quality, reliability of supplier, engineering qualifications, and facility capabilities. Many purchasers reported conducting a factory inspection and that plant approval involves reviews of manufacturing process, quality, floor failure, and various ISO and other accreditations. Purchasers also review customer references; financial, commercial risk, safety, environmental, and technical qualifications; and a supplier's ability to meet the customers' particular technical specification. One purchaser stated that after a facility is initially approved, it may place a one-time order before considering the supplier for future purchases.

²¹ ***.

²² The four firms that indicated that they do not require certification were ***.

²³ Among the firms reporting up to one year, two reported 180 days, one reported 180-365 days, and four reported 365 days. Among the firms reporting over one year, one reported 365-500 days, one reported 30-730 days and one reported 1,000 days.

Table II-7**LPTs: Importance of purchase factors, as reported by U.S. purchasers, by factor**

Factor	Very important	Somewhat important	Not important
Quality meets industry standards	23	1	---
Delivery time	22	2	---
Reliability of supply	22	2	---
Technical support/service	22	2	---
Warranties	22	2	---
Availability	21	3	---
Price	21	3	---
Product consistency	21	3	---
Evaluated cost	20	4	---
Responsiveness of supplier	20	4	---
Energy loss	18	6	---
Delivery terms	16	7	1
Long-term relationship	15	8	1
Time to fill order	15	8	1
Quality exceeds industry standards	12	10	2
Ease of doing business	10	12	2
Shell or core design	8	9	5
Discounts offered	7	15	2
U.S. transportation costs	7	15	3
Country of origin	3	16	6
Packaging	3	14	7
Product range	3	14	7
Minimum quantity requirements	1	7	16
Extension of credit	---	9	15

Source: Compiled from data submitted in response to Commission questionnaires.

Purchaser ***, an IOU, stated that after it determines whether a supplier can be cost competitive for a quality product and after it conducts a plant visit, it will then identify a trial order (which takes 6 months), complete a design review (6 months), wait for delivery (12 months), and then complete field evaluations (12-24 months). Purchaser ***, a PO, stated that it will not evaluate a new LPT plant (or buyout of an existing plant) as a potential supplier until the plant has been in operation for at least two years.

Twenty-one purchasers provided a list of their qualified suppliers. All 21 purchasers listed at least five qualified suppliers, and 14 listed at least seven qualified suppliers.²⁴ Of the 21 purchasers, 12 listed at least one supplier of Korean LPTs. Eight of the 12 firms reported that at least one U.S. supplier was qualified to supply the same MVA and kV range as the qualified Korean supplier. Three of the 12 purchasers reported that their Korean suppliers were approved for higher MVA and kV capacities than were approved for their domestic suppliers, and one purchaser listed a Korean supplier but no domestic suppliers.²⁵

²⁴ The questionnaire provided space to list seven suppliers. Purchaser *** provided a list of its 13 approved suppliers.

²⁵ ***.

Thirteen of 24 purchasers reported that a supplier had failed in its attempt to qualify product, or had lost its approved status since January 1, 2012. Purchasers named a large number of such suppliers including U.S. producers ABB, HYPO, SPX, and VA Transformer, Korean producer Hyundai, as well as nonsubject country producers, as shown in table II-8.

Table II-8
LPTs: Suppliers that failed qualification or lost approved status, as reported by U.S. purchasers

* * * * *

Changes in purchasing patterns

Purchasers were asked about changes in their purchasing patterns from different sources since January 1, 2012 (table II-9). Three purchasers reported increased domestic purchases as a result of the opening of the Mitsubishi factory, and one purchaser reported increased domestic purchases because SPX began producing very large LPTs. Among purchasers reporting decreased domestic purchases, one purchaser cited ABB relocating its U.S. production to Europe, and one cited increased marketing of imported LPTs. Among purchasers reporting increased purchases of Korean LPTs, one reported an overall increase in its purchases, and one reported purchasing a slightly higher Korean share due to quality reasons. Explanations for decreased purchases from Korea were the antidumping duty order, Korean manufacturers moving production to other countries, and a lack of price competitiveness.

Table II-9
LPTs: Changes in purchase patterns from U.S., subject, and nonsubject countries

Source of purchases	Did not purchase	Decreased	Increased	Constant	Fluctuated
United States	---	3	6	9	6
Korea	8	6	3	4	3
Other countries	1	3	5	7	8

Source: Compiled from data submitted in response to Commission questionnaires.

Fourteen of 25 purchasers reported that they had changed suppliers since January 1, 2012. *** dropped Hyundai and SPX for poor delivery and quality, dropped ABB due to uncompetitive pricing, and added Smit due to high quality and competitive pricing. *** added nonsubject country suppliers including Chint Electric (China), CG Power (India), and Koncar (Croatia). *** dropped Hyundai because of the antidumping order. *** stated that PTI Manitoba, Toshiba, and VA Transformer were identified as new suppliers capable of meeting technical requirements and that CG Power was removed from its bidders list due to poor delivery performance. *** added Efacec (Portugal) as an additional supplier “to create a broader competitive market.” *** stated that firms are usually dropped or added due to quality reasons. *** added Mitsubishi (Japan) for a specialty transformer. *** added Hyundai to its bidders list to have more suppliers and dropped the Efacec plant ***. *** dropped Efacec and Howard Industries. ***. Lastly, it stated that ABB, Mitsubishi, PTI, and WEG have rarely been cost competitive.

Eighteen of 25 purchasers reported buying LPTs from Korea before 2012. Seven of these purchasers indicated that their purchasing patterns were unchanged, two firms discontinued purchases from Korea because of the order, two firms reduced purchases from Korea because of the order, and seven firms changed purchase patterns for reasons other than the order. Among firms reporting changes for reasons other than the order, *** stated that Korean manufacturers have opened facilities outside of Korea, *** stated that domestic suppliers won more bids, and *** stated that Korean suppliers became less competitive.

One purchaser reported increased purchases of LPTs from nonsubject countries because of the antidumping order, 16 purchasers indicated that their purchases from nonsubject countries were essentially unchanged, seven reported changes unrelated to the order, and one did not purchase from nonsubject countries before or after the order. *** stated that Korean companies have opened manufacturing facilities outside of Korea. ***. *** increased the number of suppliers due to increased volume and based on bid results. *** stated that Brazilian suppliers have not been cost-competitive and that it has reduced purchases of LPTs from Israel because of quality reasons. *** purchased from nonsubject countries instead of from Korea because of a defective LPT it received. *** stated that with the opening of Mitsubishi's plant in Tennessee it no longer needed to import LPTs from Japan.

Importance of purchasing domestic product

All but one responding purchaser reported that none of their purchases required U.S.-produced product. That purchaser, ***, reported that it prefers to buy from U.S. producers.

Comparisons of domestic products, subject imports, and nonsubject imports

Purchasers were asked a number of questions comparing LPTs produced in the United States, Korea, and nonsubject countries. First, purchasers were asked for a country-by-country comparison on the same 24 factors (table II-10) for which they were asked to rate the importance. Most purchasers reported that U.S., Korean, and nonsubject LPTs were comparable on all of the specified factors.

Comparison of U.S.-produced and imported LPTs

In order to determine whether U.S.-produced LPTs can generally be used in the same applications as imports from Korea and other countries, U.S. producers, importers, and purchasers were asked how often the products can be used interchangeably. Most U.S. producers (5 of 6), reported that LPTs from all sources were "always" interchangeable (table II-11). A majority of importers (4 of 7) reported that LPTs from Korea were "sometimes" interchangeable with LPTs from domestic producers and other countries, and the remainder reported that they were "always" or "frequently" interchangeable. A majority of purchasers reported that LPTs from all sources were "always" or "frequently" interchangeable, with 13 of 19 firms reporting that U.S. and Korean LPTs were "always" or "frequently" interchangeable, and six reporting that they were "sometimes" interchangeable.

Table II-10
LPTs: Purchasers' comparisons between U.S.-produced and imported product

Factor	U.S. vs. Korea			U.S. vs. nonsubject			Korea vs. nonsubject		
	S	C	I	S	C	I	S	C	I
Availability	1	15	2	1	19	2	1	15	1
Country of origin	4	9	1	2	15	1	1	11	1
Delivery terms	3	14	1	7	14	---	3	12	2
Delivery time	4	12	2	5	14	2	3	12	2
Discounts offered	1	14	2	2	16	2	2	13	1
Ease of doing business	3	12	3	2	17	2	4	12	1
Energy loss	---	17	1	1	20	---	1	15	1
Extension of credit	---	13	1	---	17	---	1	11	1
Evaluated cost	---	16	1	2	19	1	1	15	1
Long-term relationship	4	14	---	2	19	---	3	11	3
Minimum quantity requirements	1	13	---	---	17	---	1	11	1
Packaging	1	16	---	---	20	---	1	14	1
Price ¹	1	13	3	2	17	3	2	13	2
Product consistency	1	16	1	1	18	2	3	13	1
Product range	1	14	3	---	19	2	2	13	2
Quality meets industry standards	2	16	---	1	20	---	3	12	2
Quality exceeds industry standards	1	16	1	2	18	1	3	11	3
Reliability of supply	1	16	1	1	19	1	3	13	1
Responsiveness of supplier	3	15	---	3	17	1	3	13	1
Shell or core design	3	12	1	1	16	2	2	11	2
Technical support/service	3	15	---	4	16	1	2	14	1
Time to fill order	3	13	2	3	16	2	---	14	3
U.S. transportation costs ¹	7	10	1	8	12	1	---	15	2
Warranties	---	18	---	---	20	1	1	15	1

¹ A rating of superior means that price/U.S. transportation costs is generally lower. For example, if a firm reported "U.S. superior," it meant that the U.S. product was generally priced lower than the imported product.

Note.--S=first listed country's product is superior; C=both countries' products are comparable; I=first list country's product is inferior.

Source: Compiled from data submitted in response to Commission questionnaires.

Table II-11
LPTs: Interchangeability between LPTs produced in the United States and in other countries, by country pair

Country pair	Number of U.S. producers reporting				Number of U.S. importers reporting				Number of purchasers reporting			
	A	F	S	N	A	F	S	N	A	F	S	N
U.S. vs. subject countries: U.S. vs. Korea	***	***	***	***	***	***	***	***	8	5	6	---
Nonsubject countries comparisons: U.S. vs. nonsubject	***	***	***	***	***	***	***	***	11	5	6	---
Korea vs. nonsubject	***	***	***	***	***	***	***	***	8	3	5	---

Note.--A=Always, F=Frequently, S=Sometimes, N=Never.

Source: Compiled from data submitted in response to Commission questionnaires.

Importer *** stated that factors limiting interchangeability include designs that suppliers within a certain country cannot produce, such as shell form transformers, UHV or EHV transformers (including 500 kV or 765 kV units), and large capacity units (more than 300 MVA) as well as other requirements including special sound level, loss evaluation, basic impulse voltage, and size restrictions. Importer *** identified differing physical dimensions as limiting interchangeability. Importer *** stated that LPTs are manufactured to a customers' specifications and thus cannot be replaced with an LPT manufactured for another customer.

Among purchasers, *** stated that LPTs made to IEEE design standards and in accordance with its design parameters are always interchangeable, but if made to IEC standards then they likely would not be interchangeable. *** stated that each LPT unit manufactured to a standard specification has some interchangeability. *** stated that U.S. factories can build smaller, lower voltage transformers but often cannot make the larger or higher-voltage transformers that can be produced abroad, and that DC convertor 500 kV transformers are produced in Europe but not in the United States. *** stated that LPTs from different sources have to meet the same technical specification and must be interchangeable. *** stated that LPTs must be verified to be the same size, MVA rating, voltage rating, and impedance in order to be interchangeable. *** stated that if an LPT is built to an exact specification, regardless of where it is built, it can work for the particular location. *** stated that it cannot give a generalized answer since LPTs have very specific requirements for their application including voltage, power rating, impedance, phasor relationship, and frequency. As can be seen from table II-12, nearly all responding purchasers reported that LPTs from the United States, Korea, and other countries "usually" or "always" meet minimum quality specifications.

Table II-12
LPTs: Ability to meet minimum quality specifications, by source¹

Source	Always	Usually	Sometimes	Rarely or never
United States	8	13	1	1
Korea	6	11	---	1
Other countries	8	11	1	---

¹ Purchasers were asked how often domestically produced or imported LPTs meets minimum quality specifications for their use.

Source: Compiled from data submitted in response to Commission questionnaires.

In addition, producers, importers, and purchasers were asked to assess how often differences other than price were significant in sales of LPTs from the United States, Korea, or nonsubject countries. As seen in table II-13, most U.S. producers reported that differences other than price were "never" significant, and most purchasers reported that such differences were "sometimes" significant. On the other hand, most importers reported that such differences were "always" or "frequently" significant.

U.S. producer *** reported that differences between LPTs produced in different countries include transportation, quality, availability, and technical support, and that ***. *** stated that it is at a price disadvantage to foreign competitors, including Korea, but provides a higher quality product that can last for more than 30 years.

Table II-13
LPTs: Significance of differences other than price between LPTs produced in the United States and in other countries, by country pair

Country pair	Number of U.S. producers reporting				Number of U.S. importers reporting				Number of purchasers reporting			
	A	F	S	N	A	F	S	N	A	F	S	N
U.S. vs. subject countries: U.S. vs. Korea	***	***	***	***	***	***	***	***	3	---	13	2
Nonsubject countries comparisons: U.S. vs. nonsubject	***	***	***	***	***	***	***	***	5	2	13	1
Korea vs. nonsubject	***	***	***	***	***	***	***	***	3	1	10	1

Note.--A = Always, F = Frequently, S = Sometimes, N = Never.

Source: Compiled from data submitted in response to Commission questionnaires.

Importer *** stated there are many significant factors considered in purchase decisions including: quality, lead time, advanced production facility, advanced design engineering, highly skilled manufacturing workmanship, customer service level and flexibility, supply performance record, long-term relationship, and reliability with manufacturing and design engineers. It stated that these factors are especially critical for LPTs rated above 300 MVA. Importer *** stated that quality, reference projects, after service, and lead time are significant factors, and *** stated that the factors other than price are based on a particular customer's need.

Among purchasers, *** stated that suppliers in nonsubject countries have more availability than domestic producers since they have more production capacity. *** stated that nonprice differences include pad dimensions and factory capabilities. *** stated that vendors that are familiar with its particular specifications are preferred for shorter design review periods which require shorter lead times, and also that some vendors offer warranties. *** stated that Korean manufacturers are consistently qualified and adept at meeting U.S. customer requirements.

ELASTICITY ESTIMATES

This section discusses elasticity estimates. Parties did not comment on these estimates in either their prehearing or posthearing briefs.

U.S. supply elasticity

The domestic supply elasticity²⁶ for LPTs measures the sensitivity of the quantity supplied by U.S. producers to changes in the U.S. market price of LPTs. The elasticity of domestic supply depends on several factors including the level of excess capacity, the ease with which producers can alter capacity, producers' ability to shift to production of other products, the existence of inventories, and the availability of alternate markets for U.S.-produced LPTs.

²⁶ A supply function is not defined in the case of a non-competitive market.

Analysis of these factors above indicates that the U.S. industry is likely to be able to greatly increase or decrease shipments to the U.S. market; an estimate in the range of 5 to 8 is suggested.

U.S. demand elasticity

The U.S. demand elasticity for LPTs measures the sensitivity of the overall quantity demanded to a change in the U.S. market price of LPTs. This estimate depends on factors discussed above such as the existence, availability, and commercial viability of substitute products, as well as the component share of the LPTs in the production of any downstream products (electricity generation and delivery). Based on the available information, the aggregate demand for LPTs is likely to be extremely inelastic; a range of -0.05 to -0.25 is suggested.

Substitution elasticity

The elasticity of substitution depends upon the extent of product differentiation between the domestic and imported products.²⁷ Product differentiation, in turn, depends upon such factors as quality, conditions of sale, factory capability, and customer approval. Based on available information, the elasticity of substitution between U.S.-produced LPTs and imported LPTs is likely to be in the range of 2 to 5.

²⁷ The substitution elasticity measures the responsiveness of the relative U.S. consumption levels of the subject imports and the domestic like products to changes in their relative prices. This reflects how easily purchasers switch from the U.S. product to the subject products (or vice versa) when prices change.

PART III: CONDITION OF THE U.S. INDUSTRY

OVERVIEW

The information in this section of the report was compiled from responses to the Commission’s questionnaires. Seven firms supplied information on their operations in these reviews on LPTs. Table III-1 highlights recent developments in the domestic industry. Since 2012, the U.S. industry has experienced a number of changes: the opening of new facilities, changes in ownership, consolidation, and new investments in existing facilities.

Table III-1
LPTs: Important industry events, January 2012-April 2018

Date	Event
January 2012	HYPO shipped the first transformer from its Alabama plant, which opened in November 2011. ¹
April 2012	SPX completed a 50 percent expansion of its Wisconsin plant that began in 2010. As a result of this expansion, the maximum size transformer that can be produced at the plant increased to greater than 1,000 MVA. ²
April 2013	Mitsubishi opened a transformer plant in Tennessee. The plant makes shell form transformers from 300 to more than 1,000 MVA and 161 kilovolts (kV) to 765 kV. Mitsubishi announced plans to open the plant in February 2011. ³
2013	VA Transformer opened a separate facility for producing tanks at its Virginia site. ⁴
December 2014	Caravels, doing business as Georgia Transformer Corp., purchased the Efacec plant in Georgia. ⁵
January 2015	VA Transformer formed a strategic alliance with Caravels. ⁶
August 2015	Delta Star acquired an Alstom transformer plant in Quebec, Canada with the capability to produce transformers up to 166 MVA and 315 kV. ⁷
November 2017	ABB announced that it would close its transformer plant in St Louis, Missouri and invest in production at other sites in the United States and Canada. ⁸
April 2018	HYPO announced that it would invest \$33 million in its Alabama plant, which would expand capacity by 60 percent. ⁹

Table continued on next page.

Table III-1—Continued
LPTs: Important industry events, January 2012-April 2018

¹ According to a January 2012 report, the first two units produced at the plant were expected to ship in January 2012. Hyundai Heavy Industries Website, <http://hhiamerica.com/about/sub04.htm> (accessed August 29, 2017); Zaslavsky, David, “Hyundai Power Transformers USA Celebrates,” *Montgomery Business Journal*, January 2012, <https://www.montgomerybusinessjournal.com/page.aspx?pid=4706>.

² Domestic Interested Parties’ Response to the Notice of Institution, August 2, 2017, Exhibit 9; SPX Corp., “SPX Unveils Newly Expanded SPX Transformer Solutions,” News release, April 12, 2012, http://www.spxtransformersolutions.com/assets/documents/Grand%20Opening%20Press%20Release_FINAL.pdf.

³ Domestic Interested Parties’ Response to the Notice of Institution, August 2, 2017, Exhibit 9; Mitsubishi Electric Website, <http://www.meppi.com/TransformerFactory/Pages/default.aspx> (accessed August 29, 2017); Office of the Governor of Tennessee, “Mitsubishi Electric Power Products to Build Transformers in Memphis,” News release, February 14, 2011, <https://www.tn.gov/governor/news/30399>; University of Memphis Website, Joseph Durante bio, http://www.memphis.edu/me/pdfs/joseph_durante_bio.pdf (accessed August 29, 2017).

⁴ The Virginia location produced transformers that are smaller than the subject product, and public information is not available as to whether this facility produces tanks solely for small transformers or if it also produces tanks for LPTs. Virginia Transformer Website, <http://www.vatransformer.com/about-us/#history> (accessed August 29, 2017); Virginia Transformer and Georgia Transformer brochure, April 2017, [http://www.vatransformer.com/wp-content/uploads/vtc-gtc-brochure-\(4-17\).pdf](http://www.vatransformer.com/wp-content/uploads/vtc-gtc-brochure-(4-17).pdf) (accessed August 29, 2017), pp. 2-4.

⁵ Georgia Transformer Website, <http://www.gatransformer.com/firm> (accessed August 29, 2017).

⁶ According to VA Transformer, the “agreement, which took effect Jan. 1, 2015, created the nation’s second-largest transformer manufacturing business by capacity and size, and the third largest in revenue, while providing customers with a broad range of transformers and proven engineering and manufacturing solutions from the 500 kVA to 100 MVA range offered by Virginia Transformer up to 500 MVA for Georgia Transformer’s larger products.” Virginia Transformer, “Virginia Transformer Corp. Sees Benefits One Year after Strategic Alliance,” News release, January 14, 2016.

⁷ Delta Star, “Lynchburg Headquartered Delta Star to Purchase Alstom Transformer Factory in Montreal, Canada,” News release, June 5, 2015, <http://www.deltastar.com/Portals/0/Press%20release%20-%20website.pdf>; Delta Star, “Delta Star Completes Quebec Facility Acquisition,” News release, August 1, 2015, <http://www.deltastar.com/quebec-news.pdf>.

⁸ Gray, Bruce, “ABB to Discontinue Production in St. Louis; 120 jobs lost,” *St. Louis Post-Dispatch*, November 6, 2017, https://www.stltoday.com/business/local/abb-to-discontinue-production-in-st-louis-jobs-lost/article_c18fe08f-ab76-5e02-87d7-e4ea49c1d358.html.

⁹ Brad Harper, “Hyundai Power Transformers to Expand, Add 86 Jobs,” *Montgomery Advertiser*, April 17, 2018, <https://www.montgomeryadvertiser.com/story/news/2018/04/17/hyundai-power-transformers-expand-add-86-jobs/525417002/>.

Source: Compiled from various cited sources.

Changes experienced by the industry

Domestic producers were asked to indicate whether their firm had experienced any plant openings, relocations, expansions, acquisitions, consolidations, closures, or prolonged shutdowns because of strikes or equipment failure; curtailment of production because of shortages of materials or other reasons, including revision of labor agreements; or any other change in the character of their operations or organization relating to the production of LPTs since January 1, 2012. Five of the seven responding domestic producers indicated that they had experienced such changes; their responses are presented in table III-2.

Table III-2
LPTs: Changes in the character of U.S. operations since January 1, 2012

* * * * *

Anticipated changes in operations

The Commission asked domestic producers to report anticipated changes in the character of their operations relating to the production of LPTs. Their responses appear in table III-3.

Table III-3
LPTs: Anticipated changes in the character of U.S. operations

* * * * *

U.S. PRODUCTION, CAPACITY, AND CAPACITY UTILIZATION

Table III-4 and figure III-1 present U.S. producers' production, capacity, and capacity utilization.¹ U.S. producers' capacity utilization declined *** percentage points between 2015 and 2017 as the *** percent decline in their production outstripped the *** percent decline in their capacity. Two firms reported stable capacity, two had lower capacity, and three firms had higher capacity in 2017 than in 2015. The two firms that had lower LPT capacity in 2017 than in 2015 reported capacity based on share of production on LPTs, which declined over the period. Of the *** firms that reported higher capacity: *** noted that this increase was due to ***;² *** reported that production decreased while it ***;³ *** reported that its increase in capacity was due to ***.⁴

Table III-4
LPTs: U.S. producers' production, capacity, and capacity utilization, 2015-17, January-March 2017, and January-March 2018

* * * * *

Figure III-1
LPTs: U.S. producers' production, capacity, and capacity utilization, 2015-17, January-March 2017, and January-March 2018

* * * * *

Table III-5 presents U.S. producers' overall capacity, production of products on the same machinery as LPTs, and capacity utilization. All seven firms had production of LPTs of 60 to 299 MVA top rated, and five firms (all except ***) had production of LPTs over 300 MVA top rated. In addition, five firms (all except ***) had production of other products on the same equipment and machinery used to produce LPTs. These products include medium power transformers less than 60 MVA and mobile transformers.

¹ None of the firms had toll production during 2015-17.
² Email from ***.
³ Email from ***.
⁴ Email from ***.

Overall capacity utilization declined by *** percentage points as overall capacity increased by *** percent and total production declined *** percent between 2015 and 2017. The decrease in total production and overall capacity utilization is lower than that of in-scope LPTs due to increased production of out-of-scope merchandise produced on the same equipment and machinery.

Table III-5
LPTs: U.S. producers' overall capacity and production of products on the same machinery as LPTs, 2015-17, January-March 2017, and January-March 2018

* * * * *

Table III-6 presents U.S. producers' ability to produce, and actual production of, LPTs by MVA and kV range. All seven responding producers produced LPTs between 60 to 299 MVA, with fewer producers able to produce LPTs of each increasing level. Only *** reported the ability to produce, and actual production of, LPTs from 600 to 699 MVAs and only *** reported the ability and actual production of LPTs of 700 MVAs or greater.⁵

Three firms (***,⁶ ***) noted technical limitations to their ability to produce LPTs with an MVA top-rated of more than 300, which include: clearances, crane capability, testing, and transport/lifting abilities. Three firms (***) reported economic considerations that impacted their willingness to produce LPTs of 300 MVA or more. These considerations include: the lower prices preventing the necessary investment, shrinking margins, and increasing risk of loss as unit size increases.

Only two firms, ***, reported the ability to produce 765 kV or greater LPTs. Five firms reported technical limitations that impact their willingness to produce LPTs above 764 kV. These considerations include: crane capability, facility size, testing, and transport/lifting abilities, and technology. All firms except *** reported economic considerations that impact their willingness to produce LPTs above 764 kV. These considerations include low LPT prices preventing necessary investment and low U.S. demand for such LPTs.

Table III-6
LPT: U.S. producers' ability and actual production, by range, 2012-2017

* * * * *

⁵ *** noted that it reported producing LPTs with all ranges as ***.

⁶ *** reported a decrease in production of LPTs top rated 300 MVA or more of *** percent from 2015 to 2017.

Constraints on capacity

Six of the seven responding U.S. producers reported constraints in the LPT manufacturing process.⁷ These constraints include: available skilled employees, crane capacity, engineering capacity, machine capacity, production hours, testing, and winding.

U.S. PRODUCERS' U.S. SHIPMENTS AND EXPORTS

Table III-7 presents U.S. producers' U.S. shipments, export shipments, and total shipments.

Table III-7

Large power transformers: U.S. producers' U.S. shipments, export shipments, and total shipments, 2015-17, January-March 2017, and January-March 2018

* * * * *

Two firms, *** had exports to Canada, and one firm, *** had transfers to a related firm. U.S. producers' U.S. shipments declined during 2015-17, after a *** in 2016, ending *** percent and *** percent lower in 2017 than in 2015, by quantity and value, respectively. Only *** firms, *** had increased U.S. shipments between 2015 and 2017, by quantity. *** reported that ***.⁸ U.S. shipments were *** percent and *** percent higher in January-March 2018 than in January-March 2017, by quantity and value, respectively. All producers except *** had greater U.S. shipments in January-March 2018 than January-March 2017.

Table III-8 presents U.S. producers' U.S. shipments by MVA rating category. U.S. producer's U.S. shipments of LPTs with MVA top rating of 60 to 299 MVA, which had largest share of total U.S. shipments, decreased in each year between 2015 and 2017, by quantity, while their U.S. shipments of LPTs with MVA top rating of 300 MVA or greater increased.

Table III-8

LPTs: U.S. producers' U.S. shipments, by MVA rating, 2015-17

* * * * *

⁷ *** reported that "just the market pressure on pricing constrains our growth." *** U.S. producer questionnaire, response to II-3d.

⁸ Email from ***.

U.S. PRODUCERS' INVENTORIES

Table III-9 presents U.S. producers' end-of-period inventories and the ratio of these inventories to U.S. producers' production, U.S. shipments, and total shipments. Only one firm, ***, reported any end-of-period inventories. No firms reported end-of-period inventories in 2017.

Table III-9

LPTs: U.S. producers' inventories, 2015-17, January-March 2017, and January-March 2018

* * * * *

U.S. PRODUCERS' IMPORTS

Table III-10 presents data on individual U.S. producers' U.S. production and U.S imports of LPTs. No firms had imports of LPTs from Korea, and *** imported from nonsubject sources.

Table III-10

LPTs: U.S. producers' U.S. production, imports, and import ratios to U.S. production, 2015-17, January-March 2017, and January-March 2018

* * * * *

U.S. EMPLOYMENT, WAGES, AND PRODUCTIVITY

Table III-11 shows U.S. producers' employment-related data. Between 2015 and 2017, PRWs, hours worked, wages paid, and productivity declined while hours worked per PRW, hourly wages, and unit labor costs increased.

Table III-11

LPTs: Average number of production and related workers, hours worked, wages paid to such employees, hourly wages, productivity, and unit labor costs, 2015-17, January-March 2017, and January-March 2018

* * * * *

FINANCIAL EXPERIENCE OF U.S. PRODUCERS

Background

Seven U.S. producers (ABB, Delta Star, HYPO, Mitsubishi, PTTI, SPX, and VA Transformer) reported financial results on their operations on LPTs.⁹ ***, ***, and *** reported that LPTs represent the substantial majority of their overall establishment revenue.¹⁰ Four firms reported that LPTs account for less than half of overall establishment revenue.¹¹

For the entire period of review (2012 through January-March 2018), *** accounted for the largest share of total LPT revenue (**% percent of total sales value) with *** and *** accounting for **% percent and **% percent, respectively. Smaller producers, *** accounted for **% percent, **% percent, **% percent, and **% percent, respectively, of total LPT sales value.

With regard to changes in the U.S. industry, *** completed a **%.¹² ***, increased its sales volume substantially during 2012 through 2014.¹³ ***. In early 2015, ***. In January 2018, ***.¹⁴

⁹ ***, U.S. producers reported their LPT financial results on a GAAP basis and for calendar-year periods.

ABB's U.S. transformer operations are part of the company's Power Grids division. ABB 2017 Annual Report, pp. 95-96. HYPO is a subsidiary of Hyundai Electric & Energy Systems, which is a division of Hyundai Heavy Industries. Excerpt from Hyundai Heavy Industries 2016 investor presentation, <https://seekingalpha.com/article/4026290-hyundai-heavy-industries-hyhzf-investor-presentation-slideshow>, retrieved on June 4, 2018. Mitsubishi's U.S. transformer operations are part of Mitsubishi Electric's Energy and Electric Systems segment. Mitsubishi Electric 2018 Annual Report, p. 28 and p. 74. SPX's LPT operations take place within the company's Engineered Solutions segment. SPX 2017 10-K, p. 3. Delta Star, PTTI, and VA Transformer are privately-held companies.

¹⁰ "Overall establishment" in this context refers to the facilities where LPTs are produced, which may also include the manufacture of non-LPT products.

¹¹ *** reported that LPTs account for **% percent, **% percent, and **% percent, respectively, of overall establishment revenue. *** U.S. producer questionnaire, response to III-5a. *** U.S. producer questionnaire, response to III-5a. *** U.S. producer questionnaire, response to III-5a. *** and *** reported similar LPT revenue percentages of overall establishment revenue, **% percent and **% percent, respectively, followed by **%, **% percent, and **%, **% percent. *** U.S. producer questionnaire, response to III-5a. *** U.S. producer questionnaire, response to III-5a. *** U.S. producer questionnaire, response to III-5a. *** U.S. producer questionnaire, response to III-5a.

¹² *** U.S. producer questionnaire, response to II-2a.

¹³ *** U.S. producer questionnaire, response to III-9b.

¹⁴ *** U.S. producer questionnaire, response to II-2a.

Operations on LPTs

Table III-12 presents 2015 through January-March 2018 income-and-loss data for the U.S. producers' operations on LPTs. Table III-13 presents corresponding changes in average MVA values. Table III-14 presents company-specific financial information for total operations on LPTs. Table III-15 presents summary LPT financial results data for full-years 2012 through 2017.¹⁵

Table III-12

LPTs: Results of operations of U.S. producers, 2015-17, January-March 2017, and January-March 2018

* * * * *

Table III-13

LPTs: Changes in the U.S. producers' average MVA values reported for operations 2015-17, January-March 2017, and January-March 2018

* * * * *

Table III-14

LPTs: Results of operations of U.S. producers' operations, by firm, 2015-17, January-March 2017, and January-March 2018

* * * * *

Table III-15

LPTs: Summary financial results of U.S. producers' operations, 2012-17

* * * * *

Net sales

Virtually all LPT revenue reflects commercial sales, primarily U.S. commercial sales but also including a relatively small volume of exports.¹⁶ Given the predominance of commercial sales, a single line item for total LPT revenue is presented in this section of the report.¹⁷

¹⁵ The Commission's variance analysis is generally more meaningful when product mix remains the same throughout the period. Because the U.S. industry's average per-MVA values (e.g., sales, raw material costs, conversion costs, and cost of goods sold (COGS)) reflect, in part, the impact of changes in company-specific market share and corresponding overall product mix, a variance analysis is not presented in this section of the report.

¹⁶ *** accounted for *** reported transfers, which were generally in the same range as corresponding average commercial sales values.

¹⁷ With some exceptions, LPT revenue was primarily recognized based on delivery date or date of shipment.

Net sales quantity

The U.S. industry's total sales volume reached its highest level in 2015, declined during 2016 through 2017, and was higher in January-March 2018 compared to January-March 2017 (see table III-12 and table III-15). While the majority of U.S. producers reported the same directional trend in sales volume, the magnitude of company-specific change varied widely during this timeframe.¹⁸

Net sales value

The U.S. industry's average sales value on a per-MVA basis was at its highest level in 2012 and then declined in each subsequent year (see table III-15).

The relatively wide range of company-specific average per-MVA sales values (see table III-14) for the period 2015 through January-March 2018 appears to be consistent, in general, with differences in company-specific product mix. With the exception of 2017 and interim 2018, when *** of U.S. producers reported lower average sales values, the directional trend of company-specific average sales values was generally mixed during the period. While several U.S. producers indicated that changes in LPT product mix did not have an important effect on revenue and corresponding financial results, others indicated that the pattern of average sales values does reflect, to some extent, variations in product mix.¹⁹

Cost of goods sold

Raw material

Raw material cost makes up the largest share of total LPT cost of goods sold (COGS), declining somewhat from a high of *** percent of total COGS in 2015 to a low of *** percent in January-March 2017. While presented as a single line item in table III-12, total LPT raw material cost represents a number of items whose cost fluctuated (increasing and decreasing) during 2015 through January-March 2018.^{20 21}

For the U.S. industry as a whole, average raw material cost declined during 2015-17 but was then somewhat higher in January-March 2018 compared to January-March 2017. On a company-specific basis, U.S. producers reported a range of average raw material costs, which, in general, appears to be consistent with differences in underlying product mix (see table III-

¹⁸ USITC auditor notes.

¹⁹ ***. Email with attachments (response to follow-up questions only) from ***. ***. Email with attachments (incl. revised III-9a and III-9c) from ***.

²⁰ ***. USITC auditor notes. (Note: The accompanying percentages represent the range of total raw material costs accounted for by the identified input.)

²¹ ***. *** U.S. producer questionnaire, response to III-7. ***. *** U.S. producer questionnaire, response to III-7. Email with attachments (incl. revised III-9a and III-9c) from ***. ***. Email with attachments from ***. ***. *** U.S. producer questionnaire, response to III-7. ***.

14). Directionally, U.S. producers were somewhat more uniform in terms of reporting lower average raw material cost in 2016 and in January-March 2018 compared to January-March 2017.²² Most U.S. producers indicated that raw material costs, in general, were relatively stable during 2015 through January-March 2018 with several U.S. producers also referencing corresponding cost mitigation efforts.²³

While not emphasized by U.S. producers as an important feature of their reported LPT financial results in general, at least some of the observed changes in company-specific average raw material costs likely reflect changes in product mix.

Conversion costs

Conversion cost (other factory costs and direct labor combined) increased from *** percent of total COGS in 2015 to *** percent in January-March 2017.²⁴ While the U.S. industry's average conversion cost declined in 2016, increased somewhat in 2017, and was higher in January-March 2018 compared to January-March 2017 (see table III-12), table III-14 shows that most U.S. producers reported higher average conversion costs in 2016, a somewhat more mixed pattern of increases and decreases in 2017, and predominately lower average conversion costs in January-March 2018 compared to January-March 2017. The apparent divergence between the overall trend in average conversion costs and the company-specific trend generally reflects changes in market share accounted for by individual U.S. producers (see footnote 15).²⁵

The directional pattern of company-specific changes in average conversion costs appears to be consistent with the impact of changes in sales volume and corresponding fixed cost absorption, which in some cases also offset the positive effect or lower variable costs.²⁶

Gross profit or loss

In 2015, 2016, and January-March 2017, the U.S. industry generated a gross profit, while in full-year 2017 and January-March 2018 it generated gross losses (see table III-12). On a company-specific basis and with some exceptions, *** U.S. producers reported some level of

²² The apparent divergence of the directional pattern of overall average raw material cost and company-specific average raw material cost reflects, at least in part, changes in company-specific market share (see footnote 15).

***. USITC auditor notes. ***. Email with attachment from ***.

²³ ***. Email with attachments (response to follow-up questions only) from ***. ***. Email with attachment from ***. ***. Email with attachments (incl. revised III-9a and III-9c) from ***. ***. Email from ***. ***. Email with attachment from ***. ***. Email with attachments (resp. to follow-up questions only) from ***.

²⁴ In order to improve comparability and reduce the impact of differences in company-specific assignment of direct labor and other factory costs, a single line item (conversion costs) is presented and referenced in this section of the report. USITC auditor notes.

²⁵ ***. Ibid.

²⁶ ***. Email with attachment from ***.

gross profit during 2015 through January-March 2018.²⁷ For *** U.S. producers, gross profit ratios (gross profit or loss as a percentage of total revenue) also reached their highest levels in 2016 and then contracted with several U.S. producers reporting *** in 2017.²⁸

For the U.S. industry as a whole, declines in average LPT sales values during 2015-17 were only partially offset by corresponding declines in average COGS. In contrast, the negative effect of lower average sales value in January-March 2018 compared to January-March 2017 was amplified by higher average COGS (see table III-13). On a company-specific basis, it should be noted that most U.S. producers reported *** in January-March 2018 compared to January-March 2017 and were mixed in terms of whether lower average sales value was ***. The interim-period divergence between the overall directional trend and the company-specific trend, as noted above, generally reflects changes in company-specific shares of total LPT sales (see footnote 25).

SG&A expenses

The U.S. industry's total selling, general and administrative (SG&A) expenses declined during full-year period 2015-17 and then were higher in January-March 2018 compared to January-March 2017 (see table III-12). Corresponding SG&A expense ratios (total SG&A expenses divided by total revenue) increased during 2015-17, which generally reflects declines in total LPT revenue. In contrast, the lower SG&A expense ratio in January-March 2018 compared to January-March 2017 reflects higher LPT revenue.

Table III-14 shows that some U.S. producers reported SG&A expense ratios that remained within a relatively narrow range during 2015 through January-March 2018, while others reported more notable fluctuations. Although changes in absolute SG&A expenses explain these patterns to some extent, the more substantial changes in company-specific SG&A expense ratios (increases and decreases) generally reflect changes in corresponding LPT revenue.

Operating income or loss

The U.S. industry generated operating losses of varying magnitude throughout the period of this review. While the majority of U.S. producers reported some level of gross profit during 2015 through January-March 2018, as noted above, company-specific SG&A expense ratios generally exceeded corresponding gross profit ratios.

*** were the only U.S. producers that generated operating income for the majority of the entire period of review (2012 through January-March 2018).²⁹ U.S. producers reporting

²⁷ ***.

²⁸ ***.

²⁹ USITC auditor notes.

***. Email with attachments from *** to USITC auditor, August 15, 2018.

***. Email with attachments (response to follow-up questions only) from *** to USITC auditor, June 4, 2018. ***. Email with attachment from *** to USITC auditor, June 8, 2018.

operating losses for all or the majority of the period generally attributed their poor LPT financial results to lower prices and reduced sales volume.^{30 31 32} In contrast and with respect to its LPT financial results during the review period, *** noted operational factors and the LPT sales process itself.³³ For some of these U.S. producers, continued viability, despite persistent operating losses during all or most of 2012 through January-March 2018, may reflect, to some extent, the relatively small share of company-specific overall establishment operations accounted for by LPTs (see footnote 11).

Interest expense, other expenses, and net income or loss

The majority of U.S. producers reported at least some interest expense, but were mixed in terms of the extent to which other expenses and/or other income were also reported.³⁴ The increasing total interest expense reported in table III-12 principally reflects ***. *** accounted for the majority of total reported other expenses and other income, respectively.³⁵

While sharing the same directional trend, the U.S. industry’s LPT net losses during 2015 through January-March 2018 were larger compared to corresponding operating losses due to the presence of interest expense and other expenses, which were only partially offset by other income (see table III-12).

Capital expenditures and research and development expenses

Table III-16 presents the U.S. producers’ capital expenditures and research and development (R&D) expenses related to LPT operations.

Table III-16
LPTs: Capital expenditures and research and development (R&D) expenses of U.S. producers, by firm, 2015-17, January-March 2017, and January-March 2018

* * * * *

***, accounted for the largest company-specific share of total capital expenditures for the period 2015 through January-March 2018 (**% percent),³⁶ followed by *** (**% percent),

³⁰ ***. Email with attachments (resp. to follow-up questions only) from **.

³¹ ***. Email with attachment from ***.

³² ***. Email from ***.

³³ ***. Email with attachments (incl. revised III-9a and III-9c) from ***.

³⁴ *** were the only U.S. producers that reported no interest expense during 2012 through January-March 2018.

³⁵ ***. *** U.S. producer questionnaire, III-10 and email with attachments (response to follow-up questions only) from ***.

³⁶ ***. Email with attachments (response to follow-up questions only) from *** to USITC auditor, June 4, 2018.

*** (**% percent), *** (**% percent), *** (**% percent), and *** (**% percent).³⁷ *** confirmed that *** had no capital expenditures during 2015 through January-March 2018.³⁸

The substantial majority of the U.S. industry's total R&D expenses reported for 2015 through January-March 2018 were accounted for by *** (**% percent), followed by *** (**% percent), *** (**% percent), and *** (**% percent).³⁹ *** reported no R&D expenses for 2015 through January-March 2018.

Assets and return on assets

Table III-17 presents U.S. producers' total assets and operating return on net assets.⁴⁰

Table III-17
LPTs: Total net assets and operating return on net assets of U.S. producers, by firm, 2015-17

* * * * *

³⁷ ***. Email with attachments (incl. revised III-9a and III-9c) from ***.

***. Email with attachments (resp. to follow-up questions only) from ***.

³⁸ Email with attachment from ***.

³⁹ ***. *** U.S. producer questionnaire, response to III-13 (note 2). ***. *** U.S. producer questionnaire, response to III-13 (note 2). ***. *** U.S. producer questionnaire, response to III-13 (note 2). ***. Email from ***.

⁴⁰ Total asset value (i.e., the bottom line value on the asset side of a company's balance sheet) reflects an aggregation of a number of current and non-current assets, which in many instances are not product specific. Accordingly, high-level allocation factors were likely required, to some extent, in order to report a total asset value specific to LPTs. As such, it should be noted that the pattern of total asset values reported can reflect changes in underlying asset account balances, as well as period-to-period variations in relevant allocation factors. The ability of U.S. producers to assign total asset values to discrete product lines affects the meaningfulness of calculated operating return on net assets.

PART IV: U.S. IMPORTS AND THE FOREIGN INDUSTRIES

U.S. IMPORTS

Overview

The Commission issued questionnaires to 30 firms believed to have imported LPTs since January 2012.¹ Ten firms provided data and information in response to the questionnaires, while four firms indicated that they had not imported LPTs since January 2012.² Based on official Commerce statistics for imports of LPTs, importers' questionnaire data accounted for the vast majority of total U.S. imports during 2017 and more than 95 percent of subject imports during 2017, by value. In light of the data coverage by the Commission's questionnaires, import data in this report are based on questionnaire responses.³

Imports from subject and nonsubject countries

Table IV-1 and figure IV-1 present information on U.S. imports of LPTs from Korea and all other sources. U.S. imports of LPTs from Korea fluctuated during 2015-17, ending *** percent higher in 2017 than in 2015, by MVA top rated. Two of the three firms reporting imports from Korea accounted for the majority of subject imports. *** had lower imports in 2017 compared with 2015 as it ***.⁴ The decline in imports from *** was offset by increased imports by ***. *** stated that ***. Throughout the period for which data were collected, nonsubject imports accounted for more than *** percent of the total imports by value and more than *** percent by quantity. As shown in table IV-2, the largest nonsubject sources were Austria, Mexico, the Netherlands, and Spain in 2017.

U.S. imports from Korea were *** percent lower in January-March 2018 than January-March 2017 by quantity. *** all reported *** over this period, with ***. ***.⁵ In contrast, U.S. imports from nonsubject sources were *** percent *** in January-March 2018 than January-March 2017.

¹ The Commission issued questionnaires to those firms identified in the response to the Notice of Institution, along with firms, that based on a review of data provided by U.S. Customs and Border Protection ("Customs") may have accounted for at least one percent of total imports under HTS statistical reporting numbers 8504.23.0040, 8504.23.0041, 8504.23.0045, or 8504.23.0080 in 2017 or during 2012-17.

² *** provided an importer questionnaire response for the imports from Korea in *** for which it was the consignee and ***, which also provided an importer questionnaire response, was the importer of record. This questionnaire response was not included in this report.

³ No firms reported using FTZs or bonded warehouses. One firm, ***, used the temporary importation under bond ("TIB") program.

⁴ Email from ***.

⁵ Respondent Hyundai's posthearing brief, p. 17.

Table IV-1

LPTs: U.S. imports by source, 2015-17, January-March 2017, and January-March 2018

* * * * *

Figure IV-1

LPTs: U.S. imports by source, 2015-17, January-March 2017, and January-March 2018

* * * * *

Table IV-2

LPTs: U.S. nonsubject imports by source, 2017

* * * * *

Table IV-3 and table IV-4 present U.S. importers' U.S. shipments of imports from Korea and nonsubject sources, by MVA rating and units. LPTs of 60 to 299 MVAs represented the greatest share U.S. shipments of LPTs, by units, from both Korea and nonsubject sources, except in 2015 when they were approximately *** percent of imports from Korea. By MVA top rated, LPTs over 300 MVAs represented the majority of U.S. shipments of U.S. imports of LPTs from both Korea and nonsubject sources.

The number of LPTs with 60 to 299 MVA top rated from Korea increased by *** in 2016 and then declined by *** in 2017, but were *** higher in 2017 than in 2015. In contrast, LPTs over 300 MVA top rated declined by *** in 2016 but increased *** in 2017, ending at the same level as in 2015. The number of LPTs with 60 to 299 MVA top rated from nonsubject sources increased in 2016 and then declined in 2017, ending *** higher in 2017 than in 2015. The number of LPTs over 300 MVA from nonsubject sources declined by *** in 2016 and then declined by *** in 2017 to *** less than in 2015.

The average unit value, by MVA top rated, of LPTs of 60 to 299 MVAs were greater than those of LPTs over 300 MVAs for U.S. imports of LPTs from Korea and from nonsubject sources during 2015-17.

Table IV-3

LPTs: Importers' U.S. shipments of imports from Korea, by MVA rating and units, 2015-17

* * * * *

Table IV-4

LPTs: Importers' U.S. shipments of imports from nonsubject sources, by MVA top rated and units, 2015-17

* * * * *

U.S. IMPORTERS' IMPORTS SUBSEQUENT TO MARCH 31, 2018

The Commission requested that importers indicate whether they had imported or arranged for the importation of LPTs from Korea and all other sources for delivery after March 31, 2018 (table IV-5). Three importers (***) reported arranged imports from Korea and three firms (***) reported arranged imports from all other sources.

Table IV-5
LPTs: U.S. importers' arranged imports subsequent to March 31, 2018

* * * * *

U.S. IMPORTERS' INVENTORIES

No importers held inventories of U.S. imports of LPTs from Korea or all other sources in the United States.

THE INDUSTRY IN KOREA

Overview

The Commission received responses from all four LPT producers in Korea to which it issued questionnaires: Hyosung Corporation ("Hyosung"), Hyundai Electric & Energy Systems Co., Ltd. and Hyundai Heavy Industries Co., Ltd ("Hyundai"), Iljin Electric Co., Ltd. ("Iljin"), and LSIS Co., Ltd. ("LSIS"). According to estimates requested of these responding Korean producers, the LPTs reported in questionnaires account for all known LPT production in Korea and 95 percent exports of LPTs from Korea to the United States. Staff believes responding firms accounted for all exports of LPTs from Korea to the United States in 2017.⁶ The majority of production, and an even greater majority of exports, are attributable to ***. Table IV-6 presents information on LPTs operations of the responding producers and exporters in Korea in 2017.

Table IV-6
LPTs: Summary data on producers in Korea, 2017

* * * * *

⁶ Based upon data from ***.

Changes in operations

Presented in table IV-7 are the operational changes producers of LPTs in Korea reported since January 1, 2012.

Table IV-7
LPTs: Korean producers' reported changes in operations, since January 1, 2012

* * * * *

Operations on LPTs

Table IV-8 presents aggregate production, capacity, shipments, and inventory data for responding firms in Korea.

Table IV-8:
LPTs: Data on the industry in Korea, 2015-17, January-March 2017, and January-March 2018

Item	Calendar year			January to March	
	2015	2016	2017	2017	2018
	Quantity (MVA top rated)				
Capacity	177,503	172,690	170,815	42,704	42,204
Production	139,896	130,397	122,273	30,572	18,784
End-of-period inventories	3,664	2,145	3,297	6,029	3,488
Shipments:					
Internal consumption/transfers	4,699	5,670	6,300	1,150	1,850
Commercial home market shipments	24,150	14,915	15,607	3,594	5,412
Total home market shipments	28,849	20,585	21,907	4,744	7,262
Export shipments to:					
United States	***	***	***	***	***
European Union	***	***	***	***	***
Asia	***	***	***	***	***
All other markets	***	***	***	***	***
Total exports	***	***	***	***	***
Total shipments	***	***	***	***	***
	Value (1,000 dollars)				
Shipments:					
Internal consumption/transfers	43,648	48,692	55,699	10,500	17,000
Commercial home market shipments	155,331	106,573	110,359	18,585	44,133
Total home market shipments	198,979	155,265	166,058	29,085	61,133
Export shipments to:					
United States	***	***	***	***	***
European Union	***	***	***	***	***
Asia	***	***	***	***	***
All other markets	***	***	***	***	***
Total exports	***	***	***	***	***
Total shipments	***	***	***	***	***

Table continued on next page.

Table IV-8—Continued
LPTs: Data on industry in Korea, 2015-17, January-March 2017, and January-March 2018

Item	Calendar year			January to March	
	2015	2016	2017	2017	2018
	Unit value (dollars per MVA top rated)				
Shipments:					
Internal consumption/transfers	9,289	8,588	8,841	9,130	9,189
Commercial home market shipments	6,432	7,145	7,071	5,171	8,155
Total home market shipments	6,897	7,543	7,580	6,131	8,418
Export shipments to:					
United States	***	***	***	***	***
European Union	***	***	***	***	***
Asia	***	***	***	***	***
All other markets	***	***	***	***	***
Total exports	***	***	***	***	***
Total shipments	***	***	***	***	***
	Ratios and shares (percent)				
Capacity utilization	78.8	75.5	71.6	71.6	44.5
Inventories/production	2.6	1.6	2.7	4.9	4.6
Inventories/total shipments	2.6	1.6	2.7	5.6	4.7
Share of total shipments:					
Internal consumption/transfers	3.3	4.3	5.2	4.3	9.9
Commercial home market shipments	17.1	11.3	12.9	13.5	29.1
Total home market shipments	20.4	15.6	18.1	17.8	39.1
Export shipments to:					
United States	***	***	***	***	***
European Union	***	***	***	***	***
Asia	***	***	***	***	***
All other markets	***	***	***	***	***
Total exports	***	***	***	***	***
Total shipments	100.0	100.0	100.0	100.0	100.0

Note.--Shares and ratios shown as "0.0" represent values greater than zero, but less than "0.05" percent.

Source: Compiled from data submitted in response to Commission questionnaires.

Total LPT production of responding producers in Korea by MVA top rated quantity decreased by 12.6 percent from 2015 to 2017 and was 38.6 percent lower in interim 2018 than interim 2017. *** and *** reported decreases in production of 33.9 percent and 22.2 percent, respectively, from 2015 to 2017. From interim 2017 to interim 2018, *** reported *** percent

lower production. The industry’s production capacity decreased by 3.8 percent from 2015 to 2017.^{7 8}

The industry’s capacity utilization rate decreased from 78.8 percent in 2015, to 75.5 percent in 2016, and to 71.6 percent in 2017.⁹ The capacity utilization rate was substantially lower in interim 2018 (44.5 percent) than interim 2017 (71.6 percent).

By quantity, home market shipments of LPTs in Korea decreased irregularly from 2015 to 2017 by 24.1 percent. Home market shipments accounted for 18.1 percent of LPT production in 2017, but were more than twice as high in interim 2018, at 39.1 percent, than in interim 2017. Internal consumption increased by *** percent from 2015 to 2017. The majority of internal consumption is attributable to ***.

Export shipments of LPTs from Korea made up *** percent of shipments in 2017 by quantity. Exports to the United States accounted for *** percent of total exports.¹⁰ Export shipments to the United States increased irregularly from 2015 to 2017 by *** percent. (*** export shipments to the United States *** by *** percent, while *** and *** each reported *** in their export shipments to the United States from 2015 to 2017 by *** percent and *** percent, respectively). From 2015 to 2017, total export shipments for the whole industry decreased by *** percent by quantity. By value, export shipments of LPTs to the United States from Korea decreased irregularly from 2015 to 2017 by *** percent.

Only *** reported any end-of-period inventories of LPTs from 2015 to 2017. End-of-period inventories decreased irregularly from 2015 to 2017 by *** percent. Inventories were *** percent lower in interim 2017 than in interim 2018. Inventories as a ratio to production fluctuated from *** percent in 2015, to *** percent in 2016, to *** percent in 2017.

Table IV-9 presents Korean producers’ total shipments by MVA top rated units, and value, breaking out shipments by product type.

Table IV-9
LPTs: Korean producers’ total shipments by MVA top rated units, and value 2015-17

* * * * *

Total Korean shipments of LPTs 300 MVA or more top rated accounted for the majority of LPT shipments by quantity from 2015 to 2017. The share of shipments consisting of LPTs 300 MVA or more top rated decreased from *** percent in 2015 to *** percent in 2016 and to *** percent in 2017. Shipments by value of LPTs 300 MVA or more top rated comprised a comparatively smaller share of shipments: declining irregularly from *** percent in 2015 to *** percent in 2017.

⁷ The reported reduction in capacity is due mainly to ***.

⁸ ***.

⁹ The difference between *capacity* as reported in table IV-8 versus *overall capacity* as reported in table IV-9 reflects ***.

¹⁰ ***.

Table IV-10 presents foreign producers' LPTs exports to the United States by MVA top rated, units, and value from 2015 to 2017.

Table IV-10
LPTs: Korean producers' exports to the United States by MVA top rated, units, and value, 2015-17

* * * * *

The share of LPT shipments 300 MVA or more top rated exported to the United States exceeded the industry's overall share of LPT shipments 300 MVA or more top rated in each of 2015, 2016, and 2017. By quantity, the share of LPTs 300 MVA or more top rated exported to the United States decreased irregularly from *** percent in 2015 to *** percent in 2017. By value, the share of in-scope LPTs 300 MVA or more top rated decreased irregularly from *** percent in 2015 to *** percent in 2017.

Alternative products

As shown in table IV-11, responding firms in Korea produced other products on the same equipment and machinery used to produce LPTs. Three out of four firms reported producing out-of-scope transformers below 60 MVA top rated on shared equipment and machinery. *** additionally reported producing *** on shared equipment and machinery.

On shared equipment and machinery, production of in-scope transformers comprised the majority of production in Korea, ranging from as low as 91.9 percent in 2016 to as high as 93.7 percent in calendar year 2015. Of production of LPTs, LPTs over 300 MVA top rated comprised the majority of production from 2015 to 2017.¹¹ The production of LPTs over 300 MVA top rated decreased by *** percent from 2015 to 2017. The production share of LPTs over 300 MVA top rated was lower in interim 2018 (*** percent) than in interim 2017 (*** percent)

¹¹ On a unit basis, in order to produce the quantities of shipments shown in table IV-9, production of LPTs 60 to 299 MVA top rated was two to three times higher than LPTs of 300 MVA or higher top rated.

Table IV-11

LPTs: Overall capacity and production on the same equipment as in-scope production for firms in Korea, 2015-17, January-March 2017, and January-March 2018

Item	Calendar year			January to March	
	2015	2016	2017	2017	2018
	Quantity (MVA top rated)				
Overall capacity	191,836	188,836	186,836	46,709	46,709
Production:					
LPTs 60 to 299 MVA top rated	***	***	***	***	***
LPTs over 300 MVA top rated	***	***	***	***	***
In-scope large power transformers	139,896	130,397	122,273	30,572	18,784
Out-of-scope merchandise	9,358	11,485	10,175	2,194	2,556
Total production, same machinery	149,254	141,882	132,448	32,766	21,340
	Ratios and shares (percent)				
Capacity utilization	77.8	75.1	70.9	70.1	45.7
Share of production:					
LPTs 60 to 299 MVA top rated	***	***	***	***	***
LPTs over 300 MVA top rated	***	***	***	***	***
In-scope large power transformers	93.7	91.9	92.3	93.3	88.0
Out-of-scope merchandise	6.3	8.1	7.7	6.7	12.0
Total production, same machinery	100.0	100.0	100.0	100.0	100.0
Share of in-scope production:					
LPTs 60 to 299 MVA top rated	***	***	***	***	***
LPTs over 300 MVA top rated	***	***	***	***	***
In-scope production	100.0	100.0	100.0	100.0	100.0

Note.--Shares and ratios shown as "0.0" represent values greater than zero, but less than "0.05" percent.

Source: Compiled from data submitted in response to Commission questionnaires.

Exports

Table IV-12 presents global exports of transformers from Korea, defined more broadly than the scope of this review.¹²

¹² Table IV-12 data present exports classifiable as liquid dielectric transformers having a power handling capacity exceeding 10 MVA. Also within Commerce's scope, but not shown here, may be exports of *parts* classifiable under HS subheading 8504.90.

Table IV-12
LPTs: Korean exports by destination market, 2015-17

Item	Calendar year		
	2015	2016	2017
	Value (1,000 dollars)		
Exports from Korea to the United States	239,621	249,225	225,680
Exports from Korea to other major destination markets.--			
Saudi Arabia	263,004	232,540	103,145
Bahrain	---	14,033	52,728
Canada	34,772	23,507	35,898
United Arab Emirates	48,094	25,579	24,752
Qatar	4,055	33,755	22,065
Kuwait	43,148	6,962	20,064
Indonesia	---	18,574	13,063
Sri Lanka	---	---	12,823
All other destination markets	167,201	165,285	145,795
Total Korea exports	799,896	769,459	656,013
	Share of value (percent)		
Exports from Korea to the United States	30.0	32.4	34.4
Exports from Korea to other major destination markets.--			
Saudi Arabia	32.9	30.2	15.7
Bahrain	---	1.8	8.0
Canada	4.3	3.1	5.5
United Arab Emirates	6.0	3.3	3.8
Qatar	0.5	4.4	3.4
Kuwait	5.4	0.9	3.1
Indonesia	---	2.4	2.0
Sri Lanka	---	---	2.0
All other destination markets	20.9	21.5	22.2
Total exports from Korea	100.0	100.0	100.0

Source: Official export statistic under HS subheading 8504.23 as reported by Korea Customs and Trade Development Institution, accessed June 14, 2018.

According to GTA, the leading export markets for LPTs from Korea were the United States and Saudi Arabia in each year since 2015. During 2017, the United States was the top export market for LPTs from Korea, accounting for 34.4 percent of such exports, followed by Saudi Arabia, accounting for 15.7 percent.¹³

¹³ Hyosung reported that it ***.

ANTIDUMPING OR COUNTERVAILING DUTY ORDERS IN THIRD-COUNTRY MARKETS

Korean producers of LPTs are subject to trade restrictions in two other export markets: Canada and Argentina. On April 23, 2012, based on a complaint filed by ABB Inc. of Varennes, Québec,¹⁴ and CG Power Systems Canada Inc. of Winnipeg, Manitoba, the Canada Border Services Agency (CBSA) initiated an investigation into the alleged dumping of liquid dielectric transformers having a top power handling capacity equal to or exceeding 60,000 kilovolt amperes (60 MVA), whether assembled or unassembled, complete or incomplete, originating in or exported from Korea.¹⁵ On October 22, 2012, the CBSA made a final affirmative determination of dumping of large power transformers from Korea.¹⁶ On November 20, 2012, the CITT determined that the dumping caused material injury to the domestic industry.¹⁷ The order in Canada covered HS 8504.23.0000 and unassembled goods in 8504.90.9010, 8504.90.90.82, and 8504.90.9090.¹⁸ The orders remained in place following expiry reviews in 2017-18.¹⁹

On January 2, 2013, Argentina initiated an antidumping investigation to examine imports of certain transformers from China and Korea. The order in Argentina went into effect on July 2, 2014, and covers “liquid dielectric three-phase transformers of more than 10,000 KVA but lower than or equal to 600,000 KVA” in HS subheading 8504.23.00.²⁰

¹⁴ ABB Inc. of Varennes Quebec is an affiliate of ABB Inc., a participating domestic interested party in this review.

¹⁵ The size of transformers covered in Canada’s investigation is the same as the size of transformers covered in the scope of this review. *Large Power Transformers from Korea, Inv. No. 731-TA-1189 (Final)*, USITC Publication 4346, August 2012, p. VII-7.

¹⁶ Canada Border Services Agency (CBSA), *Certain Liquid Dielectric Transformers Originating in or Exported from the Republic of Korea*, Statement of Reasons, January 5, 2018, p. 2, <https://www.cbsa-asfc.gc.ca/sima-lmsi/er-rre/tr2017/tr2017-de-eng.html>.

¹⁷ Canadian International Trade Tribunal (CITT), *Dumping and Subsidizing, Findings and Reasons*, Inquiry No. NQ-2012-001, Liquid Dielectric Transformers, Finding issued Tuesday, November 20, 2012 Reasons issued Wednesday, December 5, 2012, p. 24, http://www.citt.gc.ca/en/dumping/inquirie/findings/nq2m001_e.

¹⁸ CBSA, *Certain Liquid Dielectric Transformers Originating in or Exported from the Republic of Korea*, Statement of Reasons, January 5, 2018, 4, <https://www.cbsa-asfc.gc.ca/sima-lmsi/er-rre/tr2017/tr2017-de-eng.html>.

¹⁹ CBSA, *Certain Liquid Dielectric Transformers Originating in or Exported from the Republic of Korea*, Statement of Reasons, January 5, 2018, p.26, <https://www.cbsa-asfc.gc.ca/sima-lmsi/er-rre/tr2017/tr2017-de-eng.html>; CITT, *Dumping and Subsidizing, Findings and Reasons*, Expiry Review No. RR-2017-002 Liquid Dielectric Transformers, May 31, 2018, 27, <http://www.citt.gc.ca/en/node/8309>.

²⁰ Argentina’s order includes some smaller transformers outside the scope of this review. *Domestic Interested Parties’ Response to the Notice of Institution*, August 2, 2017, page 10, and exhibit 4; and Argentinian Ministry of Justice and Human Rights, “Ministerio de Economía y Finanzas Públicas, Resolution 308/2014, July 2, 2014, <http://servicios.infoleg.gob.ar/infolegInternet/anexos/235000-239999/235475/norma.htm>.

In addition to these investigations, Australia initiated an investigation into the alleged dumping of power transformers from China, Indonesia, Korea, Taiwan, Thailand, and Vietnam on July 29, 2013. On December 1, 2014, the investigation was terminated for ABB Chongqing, ABB Zhongshan, Toshiba CTC, CHINT, Jiangsu, UNINDO and Hyundai since the Anti-Dumping Commission determined that dumping margins were negligible. Further, the investigation for China and Korea was terminated since the volume of dumped goods was determined to be negligible.²¹

GLOBAL MARKET

Global market

Estimates of the size of the global power transformer market vary, ranging from GlobalData's estimate of \$11.3 billion in 2015 to Global Market Insights estimate of \$24 billion in 2016.²²

***.²³ China is the largest market in Asia.²⁴ In 2017, new installations of transformers greater than 220 kV in China totaled 243 gigavolt amperes (GVA).²⁵

²¹ Australian Government, Anti-Dumping Commission, *Power Transformers from the People's Republic of China, the Republic of Indonesia, the Republic of Korea, Taiwan, Thailand, and the Socialist Republic of Vietnam*, Termination Report No. 219, November 27, 2014, pp. 5–6, <http://www.adcommission.gov.au/cases/Pages/ArchivedCases/ADC219.aspx>.

²² MarketsandMarkets estimated the value of the market at \$20.7 billion in 2015, while Orbis Research estimated the market at \$16.5 billion in 2017. These reports have varying industry coverage, including nonsubject products. GlobalData, "Global Power Transformers Market Value Will Reach \$14 billion by 2020, says GlobalData," September 24, 2015, <https://energy.globaldata.com/media-center/press-releases/power-and-resources/global-power-transformers-market-value-will-reach-14-billion-by-2020-says-globaldata>; Global Market Insights, October 2017, <https://www.gminsights.com/industry-analysis/power-transformer-market-report>; MarketsandMarkets, "Power Transformer Market worth 29.91 Billion USD by 2020," News release, n.d., <https://www.marketsandmarkets.com/PressReleases/power-transformers.asp> (accessed June 11, 2018); Orbis Research, "Global Power Transformer Market and Distribution Transformer Market 2018 By Transformer Types, Key Players, Development Status, Growth Factors and Forecast 2023," June 11, 2018, <http://www.hawaiiinewsnow.com/story/38393133/global-power-transformer-market-and-distribution-transformer-market-2018-by-transformer-types-key-players-development-status-growth-factors-and>.

²³ ***.

²⁴ The presentation does not specify whether this is by quantity or value. Saeed, Saqib, "Power Transformers Market Overview," November 3, 2017, p. 8.

²⁵ One GVA equals 1,000 MVA. National Bureau of Statistics of China, "Statistical Communiqué of the People's Republic of China on the 2017 National Economic and Social Development," February 28, 2018, http://www.stats.gov.cn/english/PressRelease/201802/t20180228_1585666.html.

Table IV-13
Transformers: Global market for transformers, 50 MVA and above, by region, 2016

* * * * *

Global industry

The largest global producers of power transformers (greater than 10 MVA and 33 kV) in 2016 were ***.²⁶ ***.²⁷ Globally, the power transformer industry’s capacity utilization rate was about 70 percent in 2016.²⁸

***.²⁹ China was the largest global exporter of transformers greater than 10 MVA during 2015-17, accounting for 17 percent of global exports, followed by Korea (15 percent), Germany (8 percent), and Turkey (8 percent).³⁰

Figure IV-2
Transformers: Leading global exporters of liquid dielectric transformers having a power handling capacity exceeding 10,000 kVA (10 MVA), 2015-17

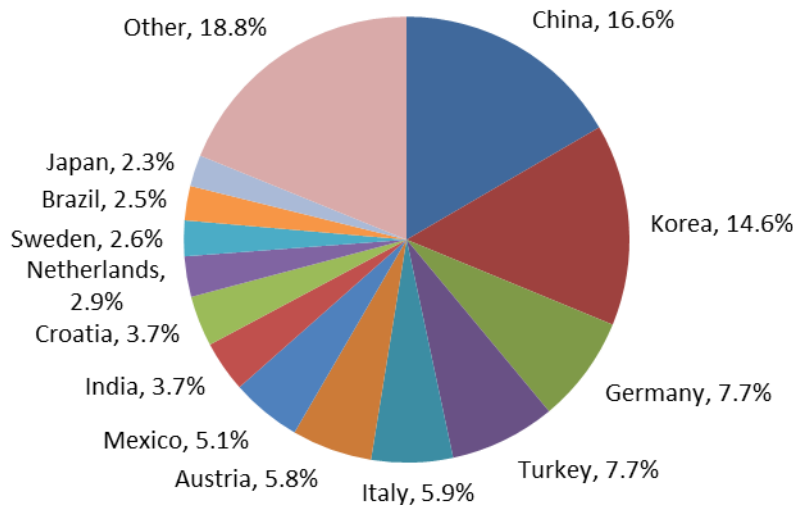

Note.--Exports in HS 8504.23, which includes nonsubject products.

Source: Global Trade Atlas database, <https://www.gtis.com> (accessed June 7, 2018).

²⁶ ***.

²⁷ ***.

²⁸ Saeed, Saqib, “Power Transformers Market Overview,” November 3, 2017, p. 40.

²⁹ ***.

³⁰ Based on exports in HS 8504.23, which includes nonsubject products. Global Trade Atlas database, <https://www.gtis.com> (accessed June 7, 2018).

***.³¹ The value of China's transformer production in 2015 was ***.³² China's leading export destinations in 2017 were countries in Asia, including Pakistan, Thailand, Bangladesh, Vietnam, and the Philippines.³³

India is not one of the leading exporters of transformers, but has substantial production capacity. India power and distribution transformer production capacity (including out-of-scope products) was 400 GVA in fiscal year 2016, and its production about 220 GVA.³⁴ Indian production capacity for power transformers was an estimated 258 GVA in fiscal year 2014.³⁵

Austria was the *** nonsubject country supplier to the United States, by volume, in 2017 (see table IV-2). Siemens has manufacturing plants in Linz and Weiz, Austria that produce LPTs. The plant in Linz can produce LPTs up to 300 MVA and 400 kV.³⁶ The plant in Weiz can produce LPTs up to 1,300 MVA and 765 kV. Annual production capacity for power transformers and shunt reactors in Weiz (as of fiscal year 2017) was 40 GVA. In fiscal year 2017, Europe accounted for 54 percent of sales for the transformer plant in Weiz (including distribution transformers) and the United States for 26 percent. Europe accounted for 61 percent of order intake and the United States for 22 percent. For transformers greater than 250 MVA and 300 kV, the United States accounted for 40 percent of sales in fiscal year 2017 and 36 percent of order intake for the plant in Weiz.³⁷

Canada was the *** supplier of LPTs to the United States. There are four manufacturers of LPTs in Canada: ABB, Delta Star, Northern Transformers, and Partner Technologies Inc. (PTI).³⁸ ABB produces LPTs up to 1,200 MVA and 800 kV in Quebec and in November 2017 announced plans to expand the plant.³⁹ Delta Star purchased an Alstom plant in Quebec in 2015, and produces transformers up to 300 MVA at that plant.⁴⁰ Northern Transformer

³¹ ***.

³² ***.

³³ IHS Markit, Global Trade Atlas database, <https://www.gtis.com> (accessed June 7, 2018).

³⁴ Mahajan, Ankush and Debashish Mazumdar, *Transformer Industry: On the Verge of Transformation*, September 2016, Edel Invest Research, p. 3.

³⁵ Ken Research, *India Power Transformer Market Outlook to 2019*, 2015, p. 7.

³⁶ Siemens website, https://w5.siemens.com/web/at/en/energy_en/trafo-linz-en/home/products_services/Pages/Transformers.aspx (accessed June 8, 2018).

³⁷ Siemens, "Siemens AG Österreich Transformers Weiz," 2017, pp. 7, 17–19, 21, https://w5.siemens.com/web/at/de/energy/trafo-weiz/home/portfolio/Documents/FY_2017_STW_Profile.pdf.

³⁸ CBSA, "Certain Liquid Dielectric Transformers Originating in or Exported from the Republic of Korea," Statement of Reasons, January 5, 2018, 4, <https://www.cbsa-asfc.gc.ca/sima-lmsi/erre/tr2017/tr2017-de-eng.html>.

³⁹ Barr, Robb, "Introducing ABB: Power and Productivity for a Better World," May 6, 2015, p. 13; Cools, Ellen, "ABB to Optimize Transformer Manufacturing Footprint," *Electrical Business*, November 6, 2017, <https://www.ebmag.com/business/abb-to-optimize-transformer-manufacturing-footprint-19990>.

⁴⁰ CBSA, "Certain Liquid Dielectric Transformers Originating in or Exported from the Republic of Korea," Statement of Reasons, January 5, 2018, p. 4, <https://www.cbsa-asfc.gc.ca/sima-lmsi/erre/tr2017/tr2017-de-eng.html>.

expanded into LPTs from smaller transformers in 2016, and produces LPTs up to 115 MVA and 60 kV.⁴¹ PTI acquired Canadian Power Transformer from Crompton Greaves Limited in 2015, which had an annual production capacity of 7.2 GVA at the time of the acquisition. PTI produces LPTs up to 575 MVA and 525 kV in Manitoba.⁴² Additional companies have transformer remanufacturing in Canada.⁴³

Mexico was the *** nonsubject supplier of LPTs to the United States. There are at least four producers of LPTs in Mexico: Condumex (IEM) (up to 200 MVA core transformers, 650 MVA shell transformers), Prolec GE (up to 1,000 MVA), Siemens (up to 450 MVA), and WEG (up to 300 MVA).⁴⁴

The Netherlands was the *** nonsubject country supplier, by volume, to the United States in 2017 (see table IV-2). Royal SMIT Transformers, part of the SGB-SMIT Group, produces LPTs up to 1,200 MVA and 765 kV at its plant in the Netherlands.⁴⁵ SGB-SMIT owns OTC Services, which does LPT repair and remanufacturing in Ohio.⁴⁶

⁴¹ CBSA, "Certain Liquid Dielectric Transformers Originating in or Exported from the Republic of Korea," Statement of Reasons, January 5, 2018, p. 5; Northern Transformer Website, <http://www.northerntransformer.com/products/power-transformers/> (accessed June 12, 2018).

⁴² CBSA, "Certain Liquid Dielectric Transformers Originating in or Exported from the Republic of Korea," Statement of Reasons, January 5, 2018, p. 5, <https://www.cbsa-asfc.gc.ca/sima-lmsi/erre/tr2017/tr2017-de-eng.html>; Avantha Group Company CG, "CG Announces the Sale of Canadian Power Transformer (CPT) Business to PTI Holdings Corporation," News release, October 27, 2015, http://www.cgglobal.com/frontend/news_detail.aspx?cntr1=FGITo393Lns=&cntr=R6YI/56Jszo=; GHMR, "Manufacturers Represented in Mississippi Transmission and Distribution," May 4, 2018.

⁴³ Barr, Robb, "Introducing ABB: Power and Productivity for a Better World," May 6, 2015, p. 13; GE Industrial Website, <http://www.geindustrial.com/services/service-centers-industrial/stoney-creek> (June 12, 2018).

⁴⁴ One more recent Siemens publication indicated that the plant in Mexico produced transformers in the category of products up to 250 MVA. IEM Website, <http://www.iem.com.mx/Paginas/Super-Alta-Potencia.aspx> (accessed June 7, 2018); Prolec GE, "Power Transformers," n.d., p. 3, http://www.prolecge.com/wp-content/uploads/2017/10/ProlecGE-power_general.pdf (accessed June 7, 2018); Siemens, "Siemens Transformers Mexico," n.d., http://transformingnews.blogspot.com/p/portfolio_01.html (accessed June 7, 2018); WEG, "Power & Distribution Transformers," 2018, p. 6, <http://ecatalog.weg.net/files/wegnet/WEG-power-transformers-usaptx13.rev.3-22-18-brochure-english.pdf>; Siemens, "Siemens AG Österreich Transformers Weiz," 2017, p. 7, 9, https://w5.siemens.com/web/at/de/energy/trafo-weiz/home/portfolio/Documents/FY_2017_STW_Profile.pdf.

⁴⁵ SGB-SMIT Group Website, <https://www.sgb-smit.com/products/large-power-transformers/overview/> (accessed Jun 8, 2018); Royal Smit, "Large Power Transformers," 2017, p. 2, https://www.sgb-smit.com/fileadmin/user_upload/Downloads/Broschueren/Large_Power_Transformers/gt2011_en.pdf.

⁴⁶ OTC Services Website, <https://www.otcservices.com/otc-services-history-2/> and <https://www.otcservices.com/powerful-facility/> (accessed June 8, 2018).

PART V: PRICING DATA

FACTORS AFFECTING PRICES

Raw material costs

The major components and raw materials used to produce LPTs include windings, controls and accessories, and grain-oriented electrical steel (“GOES”); other inputs include steel plate and dielectric mineral oil (see Part III). U.S. producers’ raw material costs as a percentage of the cost of goods sold decreased from *** percent in 2015 to *** percent in 2017. Such costs were *** percent in January-March 2017 and *** percent in January-March 2018.

U.S. producers were divided on trends in raw material prices since January 1, 2012, with three firms reporting that prices fluctuated, three reporting that they increased, and one reporting that they decreased. *** stated that prices of core steel and plate steel have increased. *** reported increased costs, increased selling prices, and lower margins. Six U.S. producers anticipate that raw material prices will increase and one anticipates that they will fluctuate.

Firms were asked about the impact on raw material prices of the announcement of Commerce’s section 232 investigation on steel products in April 2017 and the subsequent imposition of tariffs in March 2018 (table V-1).¹ Most U.S. producers reported that the April 2017 announcement had minimal effects but that the tariffs had a more substantial effect. *** stated that since GOES has a limited domestic supply, quotas and tariffs on imported GOES will lead to dramatically higher GOES prices. It also stated that prices of plate steel and cold-rolled coil have increased. *** reported increased U.S. prices for tank steel and silicon steel. *** stated that importers of LPTs will have an advantage over domestic LPT producers since they can purchase less expensive GOES.

¹ On April 19, 2017, the Secretary of Commerce initiated a Section 232 investigation, under the Trade Expansion Act of 1962, as amended (19 U.S.C. §1862), to assess the impact of steel imports on the national security of the United States, and on March 8, 2018, the President announced his decision to impose 25-percent ad valorem duties on all steel mill products. U.S. Department of Commerce website: <https://www.commerce.gov/page/section-232-investigation-effect-imports-steel-us-national-security> (accessed June 20, 2018).

Table V-1**LPTs: Firm's ratings of impact on raw materials of 232 announcement and tariffs**

Factor	1-No/minimal effects	2	3	4	5-Substantial effects
April 2017 announcement.-- U.S. producers	***	***	***	***	***
Importers	***	***	***	***	***
Purchasers	7	6	4	1	---
March 2018 tariffs.-- U.S. producers	***	***	***	***	***
Importers	***	***	***	***	***
Purchasers	6	5	1	6	---

Note.--Firms were asked to rate the effects on a scale of 1 to 5, with 1 described as no/minimal effects and 5 as substantial effects.

Source: Compiled from data submitted in response to Commission questionnaires.

Importers and purchasers generally reported minimal to moderate impacts on raw materials prices of both the April 2017 announcement and the imposition of tariffs. Importer *** stated that a drastic increase in LPT prices may cause an investor-owned utility to consider repairing an LPT instead of buying a new one. Among purchasers, *** reported that the metal product index it uses for raw material price adjustments remained flat, and that copper and GOES prices increased. *** reported that steel prices were high prior to the imposition of tariffs and that speculation further increased prices. *** stated that tank and plate steel costs rose 10 to 30 percent. *** stated that steel is a modest cost input (7 to 11 percent) for commodity price adjustment purposes under its existing blanket agreements.

Transportation costs to the U.S. market

Transportation costs for LPTs shipped from Korea to the United States averaged 6.7 percent during 2017. These estimates were derived from official import data and represent the transportation and other charges on imports.²

U.S. inland transportation costs

All responding U.S. producers and all but one responding importer reported that they typically arrange transportation to their customers. U.S. producers reported U.S. inland transportation costs of 6 to 10 percent and importers reported costs of 5 to 15 percent.

² The estimated transportation costs were obtained by subtracting the customs value from the c.i.f. value of the imports for 2017 and then dividing by the customs value based on the HTS subheadings 8504.23.0040, 8504.23.0041, 8504.23.0045, and 8504.23.0080.

PRICING PRACTICES

Pricing methods

Transaction prices for LPTs are typically determined through bid competition, as discussed later in this section. U.S. producers and importers reported selling LPTs both on single and multiple shipment contracts. U.S. producers reported that in 2017, on average, 30 percent of their contracts were for a single shipment and importers reported that 65 percent were for a single shipment. Most U.S. producers and importers reported that their multiple shipment contracts are for 2 to 3 units on average.

Most U.S. producers (** of 7) and ** of 10 importers reported that prices can be renegotiated during the contract period. However, firms reported that such renegotiations are infrequent with most U.S. producers (** of 7) reporting that renegotiations occur “sometimes” and most importers (** of 10) reporting “rarely/never.”³

Most purchasers (19 of 25) do not purchase LPTs on a fixed schedule. LPTs are typically purchased as needed based on projects and existing LPT failures, though some purchasers also have a pre-defined replacement program. Large projects and budgetary requirements can affect purchases year to year. ** generally source on a two-year cycle. ** maintains multi-year blanket purchase orders with multiple suppliers and bids those blankets every five years rather than bidding every order.

Most purchasers reported contacting a minimum of three LPT suppliers before making a purchase and a maximum of eight suppliers. ** reported contacting 20 to 25 suppliers and ** reported contacting 8 to 15 suppliers.

Sales terms and discounts

U.S. producers and importers typically quote prices on a delivered basis. Producers and importers generally reported no set discount policy.⁴ The most commonly reported sales terms for producers and importers were net 30 days.

Long-term supply agreements⁵

Most U.S. producers (** of 7) reported that they are “frequently” (**) or “sometimes” (**) required to enter a blanket agreement as a condition to bid on a particular project, and ** reported that a blanket agreement is “always” required. Importers generally reported that they are less often required to enter blanket agreements, with ** of 10 reporting “sometimes,” ** reporting having to do so “frequently,” and ** reporting “rarely/never.”

³ The remaining ** U.S. producers reported “rarely/never” and the remaining importer reported “sometimes.”

⁴ **.

⁵ Long-term agreements such as blanket and alliance agreements are discussed on p. II-1.

Most U.S. producers (** of 7) and importers (** of 10) reported that a qualification process is “always” or “frequently” required as a condition to bid on a particular project, and the remaining ** producers and ** importers reported that it is “sometimes” required. Hyundai stated that many municipal and public utilities do not require prequalification.⁶ Thirteen of 25 purchasers reported purchasing LPTs under long-term supply agreements (including blanket agreements, alliance agreements, master contracts, master service agreements, and outline agreements) since January 1, 2015. Twelve of the 13 purchasers reporting the use of such agreements provided information on up to five of their largest such agreements (table V-2).⁷ Only one of these agreements required the purchaser to buy from the supplier, and in five of these agreements, the suppliers were exclusive suppliers. Such agreements can last for many years, with some reportedly as long as 10 or more years. Firms reported agreements ending as early as 2015 and as late as 2021.

Table V-2
LPTs: Purchasers’ blanket agreements

* * * * *

Purchasers that had multiple suppliers for any long-term agreements were asked to describe how they choose which firms will supply their LPT needs over the life of the agreement. ** stated that it maintains two suppliers for each of its standard designs, that decisions are based upon which design is identified in the bid award, and that future purchases are based upon lead time needs and the manufacturer's loading and capacity. ** stated that depending on the demand quantity, an exclusive supplier or multiple providers may be selected. ** selects suppliers based on adherence to technical specifications, technical merit, quality, and price, and prefers suppliers with which it has had previous experience because of a learning curve in meeting technical requirements. ** requires suppliers to have a completed design review and site evaluation for each LPT specification.⁸ ** stated that all units are individually bid to its ** suppliers and that bids are awarded based on technical qualifications, past performance, facility capabilities, and cost/value. ** stated that it guarantees no minimum amount of work and can conduct additional competition among the contracted suppliers. ** stated that each requirement is bid typically by three long-term suppliers, with no exclusive awards.⁹

⁶ Hearing transcript, p. 136 (Kang).

⁷ Although firms were instructed to report information for the five largest agreements, they may have more than five such agreements. For example, **.

⁸ It further stated that **.

⁹ It added that **.

Initial versus evaluated costs

Suppliers typically provide a base price (the initial price including delivery and installation) and a total evaluated price (the base price plus the losses over the expected life of the transformer).¹⁰ Domestic producers stated that since LPTs are 99.8 to 99.95 percent efficient, the loss valuation does not have a large effect on the total price.¹¹

Purchasers were asked to rate how they weigh the initial LPT purchase cost compared with the evaluated/lifetime cost of owning the LPTs, including maintenance cost, evaluated loss, and other operational costs (table V-3). Most purchasers (14 of 24) “mostly” or “only” consider evaluated/lifetime costs, 7 firms equally consider initial and evaluated costs, 3 firms “mostly” consider initial costs, and no firm considers only initial costs.

**Table V-3
LPTs: Importance of initial versus evaluated/lifetime cost**

Only consider initial cost	Mostly consider initial cost	Consider initial and evaluated/lifetime cost equally	Mostly consider evaluated/lifetime cost	Only consider evaluated/lifetime cost
---	3	7	10	4

Source: Compiled from data submitted in response to Commission questionnaires.

Planned projects and renewal agreements

Purchasers were asked to identify any new projects that are planned or likely to be put out for bid in 2018 or 2019 and any blanket agreements that are likely to be renewed or put out for bid in 2018 or 2019. Nineteen firms provided such information (table V-4).

**Table V-4
LPTs: New projects and blanket agreements, 2018-2019**

* * * * *

Price leadership

Most purchasers did not identify any price leaders in the U.S. LPT market. Of the five purchasers that listed price leaders, the following firms were named: SPX (3 purchasers), HICO/Hyosung (2), Siemens (2), Delta Star (1), Hyundai (1), and VRT Power (1). *** stated that HICO/Hyosung consistently bid lower prices ***, and that Hyosung is frequently the highest-

¹⁰ Hearing transcript, p. 18 (Robinson). The total evaluated cost is determined by the purchaser and depends on where the unit is deployed. It takes into account the base price plus any losses generated by the LPT while connected to the grid over a period of time (typically 3 to 30 years). Hearing transcript, pp. 93-94 (Mason).

¹¹ Hearing transcript, p. 107 (Blake).

quality and lowest-priced supplier. *** stated that SPX has been a long-term leader on lead times and pricing for medium power transformers. *** stated that VA Transformer sets the bar for price competitiveness and support. *** stated that Delta Star had favorable transportation pricing and that Hyundai had competitive unit pricing. *** stated that HICO is very cost competitive for LPTs, that Siemens is only cost competitive for identical units (same size/voltage design), and that SPX and VRT Power are very cost competitive when their order book is only partially filled.

Bid process

Most purchasers (17 of 25) indicated that they had attended a pre-bid meeting with a potential supplier. Most of these firms reported that the discussion focuses on the RFP and technical specifications and that pricing is not discussed during pre-bid meetings. All responding U.S. producers and importers reported that bids for LPTs also include other services, including: transportation, installation, field testing, and warranties.¹²

Most (20 of 25) purchasers reported that their purchases generally involve negotiations with suppliers. Items negotiated include price, warranty, logistics, delivery, transportation, lead time, engineering, technical specification, field activities, load losses, commodity price adjustments, penalties, and discounts (including volume discounts, early payment discounts, and rebates). *** stated that it has master terms with all of its suppliers and that specifications are standard. *** stated that negotiations include lead time, terms, and cancellation schedules, and that, after consolidating top bids, it then asks for a best and final bid with any clarifications that have come up in the request for proposal (“RFP”) process. *** stated that it traditionally uses first and final bids, and that after a supplier’s design is approved, it may negotiate price, delivery, and terms and conditions. *** reported that negotiations include liquidated damages, equipment storage, acceptance, warranty, termination clauses, force majeure, limitation of liability, indemnification, insurance, title and risk of loss, and transformer losses. *** stated that quality is not negotiable, that pricing is negotiable but that it bases its decision on lowest evaluated costs.

In most cases, suppliers only have one opportunity to bid on a particular contract. *** of 7 U.S. producers and *** of 10 importers reported that there is “sometimes” more than one opportunity to bid on a particular sales agreement. *** U.S. producers and *** importers reported “rarely/never”, and *** U.S. producer and *** importers reported that there is “frequently” more than one opportunity to bid. Among purchasers, 16 of 23 indicated that they “rarely/never” allow or request suppliers more than once chance to bid on a particular sales agreement, 3 indicated “sometimes”, 3 indicated “usually”, and 1 indicated “always.”

¹² U.S. producer *** stated that its clients want the LPT delivered to their substation pad, a process which includes offloading the LPT from a railcar with a crane, transloading the LPT to a pad up to 50 miles away, and then placing the LPT on the pad. It stated that most clients also want the LPT supplier to bring in equipment and crews to assemble the LPT, to deliver oil and vacuum fill the LPT with oil, and then to perform 2 to 4 days of field testing.

*** of 7 U.S. producers reported that purchasers “sometimes” discuss the bids of competing firms with them in order to get a lower bid price, and *** reported that they “frequently” do. *** of 10 responding importers reported that purchasers “frequently” discuss with them the bids of competing firms in order to get a lower bid price, *** reported that they “sometimes” do, and *** reported that they “rarely/never” do.

Most purchasers (19 of 24) reported that they generally do not quote competing prices during negotiations. Firms that do so generally reported that they provide an explanation to their suppliers but not the actual prices. For example, purchasers may let the unsuccessful firm know that they lost due to pricing, technical disqualification, or lead times, without disclosing the pricing or other terms of the winning bid. *** stated that it can tell a supplier that the bid is not the lowest but is not allowed to share bidders’ specific financial or technical intellectual property. *** stated that it will provide a ranking and a percentile. However, *** stated that competing prices are disclosed in an electronic auction process.

Most purchasers (18 of 25) reported that they had attended a post-bid meeting with a supplier that bid on, but was not awarded, the project. Firms were then asked to describe post-bid discussions and whether there were discussions of bids, pricing, and the reason for awards. Purchasers generally indicated that they will often provide general feedback to suppliers regarding whether the supplier was price-competitive, technical issues, and lead times.

However, purchasers generally stated that they do not discuss specific pricing details including disclosing the prices of the supplier that was awarded the project.¹³

Purchasers were asked how general pricing information becomes known in the U.S. market. *** reported that it provides pricing guidance at a high level and informs bidders whether or not their pricing is competitive. *** stated that pricing information becomes known through historical price data, competitive bidding, market index trends, and commodity pricing reviews. *** stated that suppliers request feedback. *** reported that pricing information is disseminated through unsuccessful offer letters. *** stated that bidders can gauge their competitiveness based on their win and loss rates. *** reported that it has generalized discussions with unsuccessful bidders, but does not reveal specific pricing information of other bids. *** stated that they do not provide specific pricing information to unsuccessful bidders, but may provide a ranking of suppliers. *** reported that their firms do not share bid pricing details with other vendors or make vendor pricing available to the market, and *** stated that pricing information is confidential and not disclosed. *** stated that U.S. suppliers are aware that they are competing against countries that provide the best pricing. *** reported

¹³ For example, *** discusses weak or deficient factors and the evaluated cost of a supplier’s proposal, as well as the rationale for award, but does not provide comparisons of proposals or reveal merits or technical standing of competitors, manufacturing techniques, or any financial information. *** discuss general reasons for not awarding a contract, such as pricing, lead time, and inability to meet design requirements, and may provide a numerical rank (i.e., 4 out of 8 suppliers). *** discusses high level technical discrepancies and price variance (such as the price or lifetime losses were too high).

that information becomes known through a competitive RFP process. *** stated that because it buys 20 to 30 LPTs a year, it has a good idea of the market.

BID DATA

The Commission requested U.S. purchasers to provide information regarding the number of projects for bid since January 1, 2015. In total, responding purchasers reported that 571 projects were bid during this time period. Of these 571 projects, 386 had bids from domestic producers, 275 had bids from Korean suppliers, and 371 had bids from nonsubject country suppliers.

Fourteen of the 24 responding purchasers reported that they had projects for which both a domestic producer and a Korean supplier bid. There were 233 such projects. Purchasers were requested to provide the bid data for their five largest purchases of LPTs since January 1, 2015 that involved at least one bid from a U.S. producer and one bid from a Korean firm. Thirteen purchasers provided such bid data for 43 bidding events.¹⁴

Winning bids are shown in table V-5. Detailed bid data are presented in Appendix E.

Table V-5

LPTs: Winning bids reported by purchasers for bidding events involving at least one Korean and at least one domestic supplier, by year

* * * * *

A U.S. producer was the winning bidder in 15 instances, a Korean supplier was the winner in 11 instances, a nonsubject country supplier was the winner in 9 instances, in 3 instances the award was split between a U.S. producer and another source (in 2 instances nonsubject countries and in one Korea), and in 3 instances no bid was awarded.¹⁵ In the 13 instances in which Korea won part or all of the bid, purchasers gave the following reasons: board approval; Hyundai was the lowest evaluated bidder; lowest cost supplier; total ownership evaluation including commercial and technical evaluation; U.S. supplier not best overall bid for project; and working relationship with manufacturer, quality of past products, cost versus value.

In 24 of the bids, a Korean supplier had the lowest base price, in 12 bids a nonsubject country supplier had the lowest base price, and in 6 bids a domestic supplier had the lowest base price. In terms of evaluated cost, a Korean supplier was the lowest bidder in 21 instances, and a domestic supplier was lowest in 11 instances, and a nonsubject country supplier was lowest in 10 instances.

In the majority of bidding events, the award did not go to the supplier with the lowest base price or evaluated cost. In 24 bidding events, the bidder with the lowest base price did not

¹⁴ The 13 purchasers were ***.

¹⁵ In an additional instance, the purchaser indicated that the bid award was split between ***.

win the award compared to 11 events in which the bidder with the lowest base price won the award. With respect to lowest evaluated costs, in 19 events the bidder with the lowest evaluated cost did not win the award while in 16 events it did. In the remaining 4 events for which a contract was awarded, awards were split between two or more suppliers.¹⁶

Table V-6 shows a summary of comparisons of U.S. producers' and Korean suppliers' base prices and evaluated costs for the bidding events. For each bidding event, the tabulation shows the number of instances in which a U.S. producer had a lower base price or evaluated cost than all Korean suppliers' bids and the number of instances in which a Korean supplier's bid was lower than all U.S. producers' bid.

Table V-6
LPTs: Comparisons of bids of U.S. producers and Korean suppliers

Winning bidder	Base price		Evaluated cost	
	U.S. higher than Korea	U.S. lower than Korea	U.S. higher than Korea	U.S. lower than Korea
United States	8	7	7	8
Korea	10	1	10	1
Nonsubject, split award, or no award	10	6	10	6
Total	28	14	27	15

Source: Compiled from data submitted in response to Commission questionnaires.

Purchasers' perceptions of relative price trends

Purchasers were asked how the prices of LPTs from the United States had changed relative to the prices of LPTs from Korea since 2012. Most purchasers reported that prices of U.S.-produced LPTs and imported LPTs from Korea had changed by the same amount. Six purchasers reported that domestic prices were higher compared to prices of Korean product. One purchaser reported that prices had not changed.

¹⁶ In 3 additional bidding events, the purchaser reported that no contract was awarded.

APPENDIX A

***FEDERAL REGISTER* NOTICES**

The Commission makes available notices relevant to its investigations and reviews on its website, www.usitc.gov. In addition, the following tabulation presents, in chronological order, *Federal Register* notices issued by the Commission and Commerce during the current proceeding.

Citation	Title	Link
82 FR 30844 July 1, 2017	<i>Initiation of Five-Year (Sunset) Reviews</i>	https://www.gpo.gov/fdsys/pkg/FR-2017-07-03/pdf/2017-13938.pdf
82 FR 30896 July 1, 2017	<i>Large Power Transformers From Korea; Institution of a Five-Year Review</i>	https://www.gpo.gov/fdsys/pkg/FR-2017-07-03/pdf/2017-13719.pdf
82 FR 49229 October 24, 2017	<i>Large Power Transformers From Korea; Notice of Commission Determination To Conduct a Full Five-Year Review</i>	https://www.gpo.gov/fdsys/pkg/FR-2017-10-24/pdf/2017-22988.pdf
82 FR 51604 November 7, 2017	<i>Large Power Transformers From the Republic of Korea: Final Results of the Expedited First Sunset Review of the Antidumping Duty Order</i>	https://www.gpo.gov/fdsys/pkg/FR-2017-11-07/pdf/2017-24187.pdf
83 FR 15398 April 10, 2018	<i>Large Power Transformers From Korea</i>	https://www.gpo.gov/fdsys/pkg/FR-2018-04-10/pdf/2018-07305.pdf

Note.—The press release announcing the Commission’s determinations concerning adequacy and the conduct of a full or expedited review can be found at https://usitc.gov/press_room/news_release/2017/er1006l1847.htm. A summary of the Commission’s votes concerning adequacy and the conduct of a full or expedited review can be found at <https://pubapps2.usitc.gov/sunset/caseProfSuppAttmnt/download/11994>. The Commission’s explanation of its determinations can be found at <https://pubapps2.usitc.gov/sunset/caseProfSuppAttmnt/download/11995>.

APPENDIX B

LIST OF HEARING WITNESSES

CALENDAR OF PUBLIC HEARING

Those listed below appeared as witnesses at the United States International Trade Commission's hearing:

Subject: Large Power Transformers from Korea
Inv. No.: 731-TA-1189 (Review)
Date and Time: July 26, 2018 - 9:30 a.m.

Sessions were held in connection with this investigation in the Main Hearing Room (Room 101), 500 E Street, SW., Washington, DC.

OPENING REMARKS:

In Support of the Continuation of Order (**R. Alan Luberd**a, Kelley Drye & Warren LLP)

In Opposition to the Continuation of Order (**Jay Campbell**, White & Case LLP)

In Support of the Continuation of Antidumping Duty Order:

Kelley Drye & Warren LLP
Washington, DC
on behalf of

ABB Inc. ("ABB")

SPX Transformer Solutions, Inc. ("SPX")

Delta Star, Inc. ("Delta Star")

Pennsylvania Transformer Technology, Inc. ("PTTI")

Virginia Transformer Corp. and Caravels, LLC d/b/a Georgia Transformer Corp. ("VA Transformer")

Steve Robinson, Senior Vice President, ABB

Steve Newman, Vice President, Delta Star

Dennis Blake, General Manager, PTTI

**In Support of the Continuation of
Antidumping Order (continued):**

Brian Mason, President, SPX

Karen Spors, Senior Business Counsel, SPX

Prabhat Jain, Chief Executive Officer, VA Transformer

Neerja Gursahaney, Managing Director, VA Transformer

Gina Beck, Economic Consultant, Georgetown Economic Services

R. Alan Luberda)
Kathleen W. Cannon) – OF COUNSEL
Melissa M. Brewer)

**In Opposition to the Continuation of
Antidumping Duty Order:**

White & Case LLP
Washington, DC
on behalf of

Hyundai Electric & Energy System (“HEES”)

Jun Kang, Sales Manager, HEES

Ted Arkuszewski, Production Manager, Hyundai Power Transformers USA

David Bond)
Jay Campbell) – OF COUNSEL
Ron Kandler)

REBUTTAL/CLOSING REMARKS:

In Support of the Continuation of Order (**Kathleen W. Cannon**, Kelley Drye & Warren LLP)
In Opposition to the Continuation of Order (**Jay Campbell**
and **Ron Kandler**, White & Case LLP)

APPENDIX C
SUMMARY DATA

Table C-1
Large power transformers: Summary data concerning the U.S. market, 2015-17, January to March 2017, and January to March 2018

(Quantity=MVA top rated; Value=1,000 dollars; Unit values, unit labor costs, and unit expenses=dollars per MVA top rated; Period changes=percent--exceptions noted)

	Reported data					Period changes			
	2015	Calendar year 2016	2017	January-March 2017 2018		2015-17	2015-16	2016-17	Jan-Mar 2017-18
U.S. consumption quantity:									
Amount.....	***	***	***	***	***	***	***	***	***
Producers' share (fn1).....	***	***	***	***	***	***	***	***	***
Importers' share (fn1):									
Korea.....	***	***	***	***	***	***	***	***	***
Nonsubject sources.....	***	***	***	***	***	***	***	***	***
All import sources.....	***	***	***	***	***	***	***	***	***
U.S. consumption value:									
Amount.....	***	***	***	***	***	***	***	***	***
Producers' share (fn1).....	***	***	***	***	***	***	***	***	***
Importers' share (fn1):									
Korea.....	***	***	***	***	***	***	***	***	***
Nonsubject sources.....	***	***	***	***	***	***	***	***	***
All import sources.....	***	***	***	***	***	***	***	***	***
U.S. importers' U.S. shipments of imports from--									
Korea:									
Quantity.....	***	***	***	***	***	***	***	***	***
Value.....	***	***	***	***	***	***	***	***	***
Unit value.....	***	***	***	***	***	***	***	***	***
Ending inventory quantity.....	***	***	***	***	***	***	***	***	***
Nonsubject sources:									
Quantity.....	***	***	***	***	***	***	***	***	***
Value.....	***	***	***	***	***	***	***	***	***
Unit value.....	***	***	***	***	***	***	***	***	***
Ending inventory quantity.....	***	***	***	***	***	***	***	***	***
All import sources:									
Quantity.....	***	***	***	***	***	***	***	***	***
Value.....	***	***	***	***	***	***	***	***	***
Unit value.....	***	***	***	***	***	***	***	***	***
Ending inventory quantity.....	***	***	***	***	***	***	***	***	***
U.S. producers:									
Average capacity quantity.....	***	***	***	***	***	***	***	***	***
Production quantity.....	***	***	***	***	***	***	***	***	***
Capacity utilization (fn1).....	***	***	***	***	***	***	***	***	***
U.S. shipments:									
Quantity.....	***	***	***	***	***	***	***	***	***
Value.....	***	***	***	***	***	***	***	***	***
Unit value.....	***	***	***	***	***	***	***	***	***
Export shipments:									
Quantity.....	***	***	***	***	***	***	***	***	***
Value.....	***	***	***	***	***	***	***	***	***
Unit value.....	***	***	***	***	***	***	***	***	***
Ending inventory quantity.....	***	***	***	***	***	***	***	***	***
Inventories/total shipments (fn1).....	***	***	***	***	***	***	***	***	***
Production workers.....	***	***	***	***	***	***	***	***	***
Hours worked (1,000s).....	***	***	***	***	***	***	***	***	***
Wages paid (\$1,000).....	***	***	***	***	***	***	***	***	***
Hourly wages.....	***	***	***	***	***	***	***	***	***
Productivity (MVA top rated per 1,000 hours)	***	***	***	***	***	***	***	***	***
Unit labor costs.....	***	***	***	***	***	***	***	***	***
Net sales:									
Quantity.....	***	***	***	***	***	***	***	***	***
Value.....	***	***	***	***	***	***	***	***	***
Unit value.....	***	***	***	***	***	***	***	***	***
Cost of goods sold (COGS).....	***	***	***	***	***	***	***	***	***
Gross profit of (loss).....	***	***	***	***	***	***	***	***	***
SG&A expenses.....	***	***	***	***	***	***	***	***	***
Operating income or (loss).....	***	***	***	***	***	***	***	***	***
Net income or (loss).....	***	***	***	***	***	***	***	***	***
Capital expenditures.....	***	***	***	***	***	***	***	***	***
Unit COGS.....	***	***	***	***	***	***	***	***	***
Unit SG&A expenses.....	***	***	***	***	***	***	***	***	***
Unit operating income or (loss).....	***	***	***	***	***	***	***	***	***
Unit net income or (loss).....	***	***	***	***	***	***	***	***	***
COGS/sales (fn1).....	***	***	***	***	***	***	***	***	***
Operating income or (loss)/sales (fn1).....	***	***	***	***	***	***	***	***	***
Net income or (loss)/sales (fn1).....	***	***	***	***	***	***	***	***	***

Note.--Shares and ratios shown as "0.0" represent values greater than zero, but less than "0.05" percent.

fn1.--Reported data are in percent and period changes are in percentage points.

fn2.--Undefined.

Source: Compiled from data provided in response to Commission questionnaire.

HISTORICAL DATA

In the original investigation, Petitioners and Respondent Hyosung agreed that volume expressed in MVA (rather than value) was the most reasonable basis for measuring apparent U.S. consumption and market share.¹ Therefore, tables in historical appendix C present apparent U.S. consumption and market share on the basis of quantity only. To address certain firms' reporting of inventories, which were actually finished units in transit; imports (rather than shipments of imports) from subject and non-subject sources were used to calculate apparent U.S. consumption. Table C-2 presented the U.S. market for all LPTs, using top-rated MVAs as a measure of quantity, while table C-3 used units of LPTs as a measure of quantity.

¹ Petitioners' posthearing brief, Answers to Commission questions, p. 82; Respondent Hyosung's posthearing brief, p. 4.

Table C-2

LPTs: Summary data (using top rated MVA as quantity) concerning the U.S. market, 2009-11, January-March 2011, and January-March 2012

(Quantity=MVA, value=1,000 dollars, unit values, unit labor costs, and unit expenses are per MVA; period changes=percent, except where noted)

Item	Reported data					Period changes			
	2009	2010	2011	January-March		2009-11	2009-10	2010-11	Jan.-March 2011-12
				2011	2012				
U.S. consumption quantity:									
Amount	112,219	111,383	137,243	29,009	26,245	22.3	-0.7	23.2	-9.5
Producers' share (1)	17.6	17.0	16.1	15.3	17.9	-1.5	-0.6	-0.9	2.6
Importers' share (1):									
Korea	***	***	***	***	***	***	***	***	***
All other sources	***	***	***	***	***	***	***	***	***
Total imports	82.4	83.0	83.9	84.7	82.1	1.5	0.6	0.9	-2.6
U.S. imports from:									
Korea:									
Quantity	***	***	***	***	***	***	***	***	***
Value	***	***	***	***	***	***	***	***	***
Unit value	***	***	***	***	***	***	***	***	***
Ending inventory quantity	***	***	***	***	***	***	***	***	***
All other sources:									
Quantity	***	***	***	***	***	***	***	***	***
Value	***	***	***	***	***	***	***	***	***
Unit value	***	***	***	***	***	***	***	***	***
Ending inventory quantity	***	***	***	***	***	***	***	***	***
All sources:									
Quantity	92,465	92,485	115,177	24,582	21,554	24.6	0.0	24.5	-12.3
Value	813,330	766,644	845,310	178,950	141,285	3.9	-5.7	10.3	-21.0
Unit value	\$8,796	\$8,289	\$7,339	\$7,280	\$6,555	-16.6	-5.8	-11.5	-10.0
Ending inventory quantity	8,586	5,948	12,611	5,626	11,741	46.9	-30.7	112.0	108.7
U.S. producers':									
Average capacity quantity	43,346	50,200	59,439	14,632	19,168	37.1	15.8	18.4	31.0
Production quantity	20,469	19,426	24,049	4,706	6,448	17.5	-5.1	23.8	37.0
Capacity utilization (1)	47.2	38.7	40.5	32.2	33.6	-6.8	-8.5	1.8	1.5
U.S. shipments:									
Quantity	19,754	18,898	22,066	4,427	4,691	11.7	-4.3	16.8	6.0
Value	276,436	211,558	207,349	45,747	47,952	-25.0	-23.5	-2.0	4.8
Unit value	\$13,994	\$11,195	\$9,397	\$10,334	\$10,222	-32.9	-20.0	-16.1	-1.1
Export shipments:									
Quantity	***	***	***	***	***	***	***	***	***
Value	***	***	***	***	***	***	***	***	***
Unit value	***	***	***	***	***	***	***	***	***
Ending inventory quantity	***	***	***	***	***	***	***	***	***
Inventories/total shipments (1)	***	***	***	***	***	***	***	***	***
Production workers	***	***	***	***	***	***	***	***	***
Hours worked (1,000s)	***	***	***	***	***	***	***	***	***
Wages paid (\$1,000s)	***	***	***	***	***	***	***	***	***
Hourly wages	***	***	***	***	***	***	***	***	***
Productivity (MVA/1,000 hours)	***	***	***	***	***	***	***	***	***
Unit labor costs	***	***	***	***	***	***	***	***	***
Net sales:									
Quantity	***	***	***	***	***	***	***	***	***
Value	***	***	***	***	***	***	***	***	***
Unit value	***	***	***	***	***	***	***	***	***
Cost of goods sold (COGS)	***	***	***	***	***	***	***	***	***
Gross profit or (loss)	***	***	***	***	***	***	***	***	***
SG&A expenses	***	***	***	***	***	***	***	***	***
Operating income or (loss)	***	***	***	***	***	***	***	***	***
Capital expenditures	***	***	***	***	***	***	***	***	***
Unit COGS	***	***	***	***	***	***	***	***	***
Unit SG&A expenses	***	***	***	***	***	***	***	***	***
Unit operating income or (loss)	***	***	***	***	***	***	***	***	***
COGS/sales (1)	***	***	***	***	***	***	***	***	***
Operating income or (loss)/ sales (1)	***	***	***	***	***	***	***	***	***

(1) "Reported data" are in percent and "period changes" are in percentage points.

(2) Not applicable.

Note.--Financial data are reported on a fiscal year basis and may not necessarily be comparable to data reported on a calendar year basis. Because of rounding, figures may not add to the totals shown. Unit values and shares are calculated from the unrounded figures.

Source: Compiled from data submitted in response to Commission questionnaires.

Table C-3

LPTs: Summary data (using units of LPTs as quantity) concerning the U.S. market, 2009-11, January-March 2011, and January-March 2012

(Quantity=units, value=1,000 dollars, unit values, unit labor costs, and unit expenses are per unit; period changes=percent, except where noted)

Item	Reported data					Period changes			
	2009	2010	2011	January-March		2009-11	2009-10	2010-11	Jan.-March 2011-12
				2011	2012				
U.S. consumption quantity:									
Amount	568	513	622	126	114	9.5	-9.7	21.2	-9.5
Producers' share (1)	30.3	27.7	25.6	27.0	30.7	-4.7	-2.6	-2.1	3.7
Importers' share (1):									
Korea	***	***	***	***	***	***	***	***	***
All other sources	***	***	***	***	***	***	***	***	***
Total imports	69.7	72.3	74.4	73.0	69.3	4.7	2.6	2.1	-3.7
U.S. imports from:									
Korea:									
Quantity	***	***	***	***	***	***	***	***	***
Value	***	***	***	***	***	***	***	***	***
Unit value	***	***	***	***	***	***	***	***	***
Ending inventory quantity	***	***	***	***	***	***	***	***	***
All other sources:									
Quantity	***	***	***	***	***	***	***	***	***
Value	***	***	***	***	***	***	***	***	***
Unit value	***	***	***	***	***	***	***	***	***
Ending inventory quantity	***	***	***	***	***	***	***	***	***
All sources:									
Quantity	396	371	463	92	79	16.9	-6.3	24.8	-14.1
Value	813,330	766,644	845,310	178,950	141,285	3.9	-5.7	10.3	-21.0
Unit value	\$2,053,864	\$2,066,426	\$1,825,724	\$1,945,109	\$1,788,418	-11.1	0.6	-11.6	-8.1
Ending inventory quantity	39	21	42	22	33	7.7	-46.2	100.0	50.0
U.S. producers':									
Average capacity quantity	508	475	499	121	144	-1.8	-6.5	5.1	19.0
Production quantity	177	147	175	35	45	-1.1	-16.9	19.0	28.6
Capacity utilization (1)	34.8	30.9	35.1	28.9	31.3	0.2	-3.9	4.1	2.3
U.S. shipments:									
Quantity	172	142	159	34	35	-7.6	-17.4	12.0	2.9
Value	276,436	211,558	207,349	45,747	47,952	-25.0	-23.5	-2.0	4.8
Unit value	\$1,607,186	\$1,489,845	\$1,304,082	\$1,345,500	\$1,370,057	-18.9	-7.3	-12.5	1.8
Export shipments:									
Quantity	***	***	***	***	***	***	***	***	***
Value	***	***	***	***	***	***	***	***	***
Unit value	***	***	***	***	***	***	***	***	***
Ending inventory quantity	***	***	***	***	***	***	***	***	***
Inventories/total shipments (1)	***	***	***	***	***	***	***	***	***
Production workers	***	***	***	***	***	***	***	***	***
Hours worked (1,000s)	***	***	***	***	***	***	***	***	***
Wages paid (\$1,000s)	***	***	***	***	***	***	***	***	***
Hourly wages	***	***	***	***	***	***	***	***	***
Productivity (units/1,000 hours)	***	***	***	***	***	***	***	***	***
Unit labor costs	***	***	***	***	***	***	***	***	***
Net sales:									
Quantity	***	***	***	***	***	***	***	***	***
Value	***	***	***	***	***	***	***	***	***
Unit value	***	***	***	***	***	***	***	***	***
Cost of goods sold (COGS)	***	***	***	***	***	***	***	***	***
Gross profit or (loss)	***	***	***	***	***	***	***	***	***
SG&A expenses	***	***	***	***	***	***	***	***	***
Operating income or (loss)	***	***	***	***	***	***	***	***	***
Capital expenditures	***	***	***	***	***	***	***	***	***
Unit COGS	***	***	***	***	***	***	***	***	***
Unit SG&A expenses	***	***	***	***	***	***	***	***	***
Unit operating income or (loss)	***	***	***	***	***	***	***	***	***
COGS/sales (1)	***	***	***	***	***	***	***	***	***
Operating income or (loss)/ sales (1)	***	***	***	***	***	***	***	***	***

(1) "Reported data" are in percent and "period changes" are in percentage points.

(2) Not applicable.

Note.--Financial data are reported on a fiscal year basis and may not necessarily be comparable to data reported on a calendar year basis. Because of rounding, figures may not add to the totals shown. Unit values and shares are calculated from the unrounded figures.

Source: Compiled from data submitted in LPTs in response to Commission questionnaires.

APPENDIX D
COMMENTS REGARDING THE EFFECTS OF THE ORDERS AND THE LIKELY
EFFECTS OF REVOCATION

The Commission requested U.S. producers to report the significance of the existing antidumping duty order covering imports of LPTs from Korea in terms of their effect on their firm's production capacity, production, U.S. shipments, inventories, purchases, employment, revenues, costs, profits, cash flow, capital expenditures, research and development expenditures, and asset values. Specifically, U.S. producers were asked to indicate the particular effect of imposition of the order and likely impact of revocation of the order. The Commission also requested that U.S. importers, U.S. purchases, and foreign producers report the effect of imposition of the order and likely impact of revocation of order; specifically, the significance of the existing antidumping duty order covering imports of LPTs from Korea in terms of their effect on imports, U.S. shipments of imports, and inventories. The Commission suggested that U.S. importers may wish to compare operations before and after the imposition of the order.

The Commission also requested that U.S. producers, U.S. importers, U.S. purchases, and foreign producers report on anticipated changes in their operations if the order was to remain place and if the order was to be revoked.

Table D-1
LPTs: Narratives on impact of orders and anticipated impact of revocation of orders

* * * * *

APPENDIX E

BID DATA

Table E-1
LPTs: Bids involving at least one domestic and one Korean supplier, as reported by purchasers

* * * * *

