

In the Matter of

**CERTAIN LTE- AND 3G-COMPLIANT
CELLULAR COMMUNICATIONS DEVICES**

Investigation No. 337-TA-1138

Publication 5258

February 2022

U.S. International Trade Commission

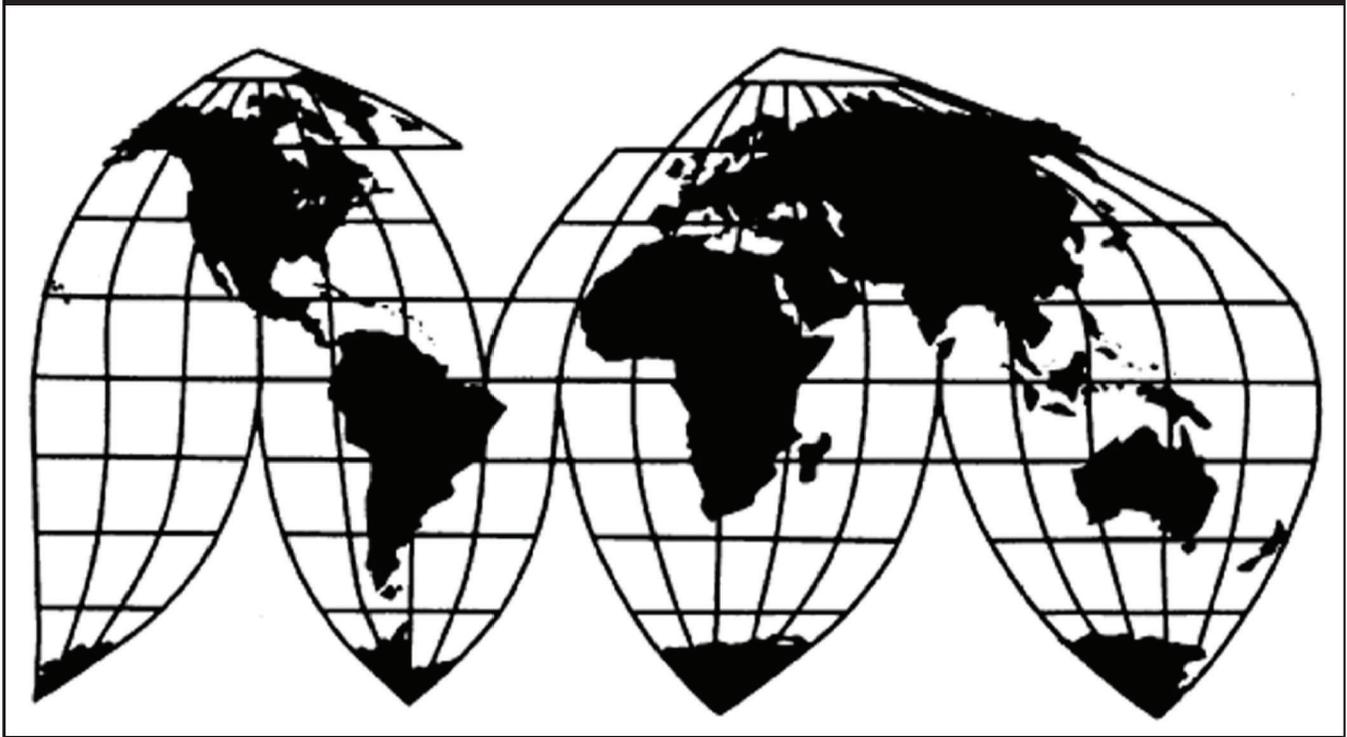

Washington, DC 20436

U.S. International Trade Commission

COMMISSIONERS

David S. Johanson, Chairman
Rhonda K. Schmidlein, Commissioner
Jason E. Kearns, Commissioner
Randolph J. Stayin, Commissioner
Amy A. Karpel, Commissioner

**Address all communications to
Secretary to the Commission
United States International Trade Commission
Washington, DC 20436**

U.S. International Trade Commission

Washington, DC 20436
www.usitc.gov

In the Matter of

CERTAIN LTE- AND 3G-COMPLIANT CELLULAR COMMUNICATIONS DEVICES

Investigation No. 337-TA-1138



UNITED STATES INTERNATIONAL TRADE COMMISSION
Washington, D.C.

In the Matter of

**CERTAIN LTE- AND 3G-COMPLIANT
CELLULAR COMMUNICATIONS
DEVICES**

Investigation No. 337-TA-1138

**NOTICE OF A COMMISSION DETERMINATION TO REVIEW IN PART A FINAL
INITIAL DETERMINATION FINDING NO VIOLATION OF SECTION 337 AND, ON
REVIEW, TO AFFIRM THE FINAL INITIAL DETERMINATION'S FINDING OF NO
VIOLATION; TERMINATION OF THE INVESTIGATION**

AGENCY: U.S. International Trade Commission.

ACTION: Notice.

SUMMARY: Notice is hereby given that, on February 18, 2020, the presiding administrative law judge ("ALJ") issued a final initial determination ("ID") finding no violation of section 337 in the above-captioned investigation. The Commission has determined to review the ID in part and, on review, has determined to affirm the final ID's finding of no violation. The investigation is terminated.

FOR FURTHER INFORMATION CONTACT: Richard P. Hadorn, Esq., Office of the General Counsel, U.S. International Trade Commission, 500 E Street, S.W., Washington, D.C. 20436, telephone (202) 205-3179. Copies of non-confidential documents filed in connection with this investigation may be viewed on the Commission's electronic docket (EDIS) at <https://edis.usitc.gov>. For help accessing EDIS, please email EDIS3Help@usitc.gov. General information concerning the Commission may also be obtained by accessing its Internet server at <https://www.usitc.gov>. Hearing-impaired persons are advised that information on this matter can be obtained by contacting the Commission's TDD terminal, telephone (202) 205-1810.

SUPPLEMENTARY INFORMATION: The Commission instituted this investigation on October 19, 2018, based on a complaint filed by INVT SPE LLC ("INVT") of San Francisco, California. 83 *Fed. Reg.* 53105 (Oct. 19, 2018). The complaint alleges violations of section 337 of the Tariff Act of 1930, as amended (19 U.S.C. 1337) ("Section 337"), in the importation into the United States, the sale for importation, or the sale within the United States after importation of certain LTE- and 3G-compliant cellular communications devices by reason of infringement of certain claims of U.S. Patent Nos. 7,339,949 ("the '949 patent"); 7,848,439 ("the '439 patent"); 6,760,590 ("the '590 patent"); 7,206,587 ("the '587 patent"); and 7,764,711 ("the '711 patent"). *Id.* The complaint further alleges that a domestic industry exists. *Id.* The notice of investigation named as respondents Apple Inc. ("Apple") of Cupertino, California; HTC Corporation of Taoyuan City, Taiwan; HTC America, Inc. of Seattle, Washington; ZTE Corporation of

Guangdong, China; and ZTE (USA) Inc. of Richardson, Texas (collectively, the “Respondents”). *Id.* at 53106. The Office of Unfair Import Investigations (“OUII”) is also named as a party. *Id.*

The Commission later terminated the investigation as to: (1) the ’711 patent, Order No. 20 (Mar. 11, 2019), *unreviewed by* Comm’n Notice (Mar. 25, 2019); and (2) the ’949 patent and claim 3 of the ’439 patent, Order No. 46 (July 31, 2019), *unreviewed by* Comm’n Notice (Aug. 20, 2019). Remaining in the investigation are claims 3 and 4 of the ’590 patent, claim 4 of the ’587 patent, and claims 1 and 2 of the ’439 patent.

On February 18, 2020, the ALJ issued the final ID finding no violation of Section 337. *See ID.* On March 2, 2020, INVT and OUII each filed petitions for review of certain findings in the ID and Respondents filed a contingent petition for review. On March 17, 2020, the parties filed responses to each other’s petitions.

On April 3, 2020, the ALJ issued a Recommended Determination on the Public Interest, Remedy, and Bond (“RD”) recommending that, should the Commission reverse her findings in the ID and find a violation of Section 337, then the Commission should issue a limited exclusion order, with a delayed implementation, and cease and desist orders against each Respondent. RD at 3. The RD also recommends imposing no bond during the period of Presidential review. *Id.*

On April 8, 2020, Apple filed a motion for sanctions against INVT (“Apple Motion”). On April 20, 2020, INVT filed an opposition to the motion. On April 29, 2020, Apple filed a motion for leave to file a reply in support of its motion.

On May 4, 2020, the Commission received a submission on the public interest from INVT. On May 5, 2020, the Commission received submissions on the public interest from the following non-parties: (1) ACT / The App Association; (2) Cisco Systems, Inc., Dell Technologies, Inc., Hewlett Packard Enterprise Company, HP Inc., and the High Tech Inventors Alliance; and (3) Computer & Communications Industry Association. On May 6, 2020, the Commission also received a submission on the public interest from non-party Fair Standards Alliance.

Having reviewed the record in this investigation, including the ALJ’s orders and ID, as well as the parties’ petitions and responses thereto, the Commission has determined to review the ID in part, as follows:

The Commission has determined to review and, on review, take no position on the ID’s findings regarding the following issues: (1) whether INVT has standing before the Commission to assert the ’590, ’587, and ’439 patents; (2) whether INVT satisfied the economic prong of the domestic industry requirement; and (3) whether Respondents’ affirmative defenses of (i) patent exhaustion, (ii) equitable estoppel and waiver, and (iii) unclean hands bar the requested relief.

The Commission has determined not to review the remaining findings in the final ID.

Accordingly, the Commission has determined to affirm the final ID’s finding of no violation of section 337. The investigation is terminated.

The Commission has also determined to deny Apple's motion for sanctions because the information at issue was not disclosed to unauthorized persons nor was it placed on the public record. *See* Apple Motion, Exh. 13.

The Commission vote for these determinations took place on June 1, 2020.

The authority for the Commission's determination is contained in Section 337 of the Tariff Act of 1930, as amended, 19 U.S.C. 1337, and in Part 210 of the Commission's Rules of Practice and Procedure, 19 CFR Part 210.

By order of the Commission.

A handwritten signature in black ink, appearing to read 'Lisa R. Barton', with a stylized flourish at the end.

Lisa R. Barton
Secretary to the Commission

Issued: June 1, 2020

PUBLIC CERTIFICATE OF SERVICE

I, Lisa R. Barton, hereby certify that the attached **NOTICE** has been served via EDIS upon the Commission Investigative Attorney, **Reginald Lucas, Esq.**, and to the following parties as indicated, on **June 1, 2020**.



Lisa R. Barton, Secretary
U.S. International Trade Commission
500 E Street, SW, Room 112
Washington, DC 20436

On Behalf of Complainant INVT SPE LLC:

Bryan J. Vogel, Esq.
ROBIN KAPLAN LLP
399 Park Avenue, Suite 3600
New York, NY 10022
Email: bvogel@robinskaplan.com

- Via Hand Delivery
- Via Express Delivery
- Via First Class Mail
- Other: Email Notification of Availability for Download

On Behalf of Respondent Apple Inc.:

Robert A. Appleby, P.C.
KIRKLAND & ELLIS LLP
601 Lexington Avenue
New York, New York 10022
Email: Robert.appleby@kirkland.com

- Via Hand Delivery
- Via Express Delivery
- Via First Class Mail
- Other: Email Notification of Availability for Download

On Behalf of Respondents HTC Corporation and HTC America, Inc.:

Stephen S. Korniczky, Esq.
SHEPPARD, MULLIN, RICHTER & HAMPTON LLP
12275 El Camino Real, Suite 200
San Diego, California 92130
Email: skorniczky@sheppardmullin.com

- Via Hand Delivery
- Via Express Delivery
- Via First Class Mail
- Other: Email Notification of Availability for Download

**CERTAIN LTE- AND 3G-COMPLIANT CELLULAR
COMMUNICATIONS DEVICES**

Inv. No. 337-TA-1138

Certificate of Service – Page 2

**On Behalf of Respondents ZTE Corporation and ZTE (USA)
Inc.:**

Jay H. Reiziss, Esq.
MCDERMOTT WILL & EMERY LLP
500 North Capitol Street, NW
Washington, DC 20001
Email: jreiziss@mwe.com

- Via Hand Delivery
- Via Express Delivery
- Via First Class Mail
- Other: Email Notification
of Availability for Download

UNITED STATES INTERNATIONAL TRADE COMMISSION

WASHINGTON, D.C.

In the Matter of

**CERTAIN LTE- AND 3G-COMPLIANT
CELLULAR COMMUNICATIONS
DEVICES**

Inv. No. 337-TA-1138

**ANALYSIS AND FINDINGS WITH RESPECT TO RECOMMENDATION ON THE
PUBLIC INTEREST, AND RECOMMENDATION ON REMEDY AND BOND**

Administrative Law Judge MaryJoan McNamara

(April 3, 2020)

I. OVERVIEW: PUBLIC INTEREST AND REMEDY AND BOND¹

The Initial Determination on Violation (“ID”) was filed on EDIS on February 18, 2020. (Doc. ID No. 70834 (Feb. 18, 2020)). The ID found, *inter alia*, that Complainant INVT SPE LLC (“INVT”) has not proven that Respondents Apple, Inc. (“Apple”), HTC Corporation and HTC America (collectively, “HTC”) and ZTE Corporation and ZTE (USA), Inc. (collectively,

¹ As this was being written and completed, the United States economy has been profoundly disrupted by the Covid-19 pandemic. While this Recommendation was based on information, data and analyses that were given in evidence last September during the evidentiary hearing (“Hearing”) that was held on September 12, 13, 17, 18, 19, 20 and 24, 2019, and in post-Hearing briefing, it may be that much of what of what is discussed is no longer relevant. Moreover, despite the analyses, testimony and arguments of the Parties, this may be a case in which it clearly would be against the Public Interest to exclude Apple from the U.S. marketplace, thereby causing unnecessary consumer pain to millions of people who have lost their employment, and additional harm to the economy. (*See, infra*, on “switching costs.”). Equally, an exclusion order could have an adverse impact on Apple. At the time of the Hearing, Apple employed some 90,000 people in the United States and supported another 450,000 developers and suppliers of parts to Apple in the United States. *See, infra*. The data on Apple’s employment in the United States may be the most significant and important information in this document. Similarly, there could be unnecessary consumer costs if HTC’s and ZTE’s Accused Products were to be excluded from the marketplace. The rest may no longer be relevant.

PUBLIC VERSION

“ZTE” and with Apple and HTC, “Respondents”): (a) violated Section 337, i.e. 19 U.S.C § 1337; and (b) that none of the three (3) Asserted Patents have been infringed or are standard essential patents (“SEPs”); and (c) that the asserted claims of the three (3) Asserted Patents are valid.²

Because of the salient factual and legal findings in the ID, remedies are not required.

The analyses findings and recommendations are offered if the Commission overturns the ultimate finding of the ID that none of the Accused Products³ infringe the Asserted Patents or that none of the Respondents have violated Section 337. Or to state it differently, this document considers the public interest factors and remedy and bond *in the alternative* pursuant to 19 C.F.R. § 210.42(a)(1)(ii).

With respect to the public interest factors, this recommended decision in the alternative finds that: (1) the public interest factors would not prevent the Commission from issuing a remedy; and (2) Respondents’ argument that INVT’s proposed licensing offers to them were not “fair, reasonable and non-discriminatory” (“FRAND”) is not one of the public interest factor considerations and would not preclude the Commission from issuing a remedy as Respondents have argued.⁴

² The three (3) Asserted Patents that are discussed in the ID with findings that none of the patents are SEPs, that none of the patents are infringed, and each of the patents is valid are: U.S. Patent No. U.S. Patent No. 6,760,590 (“the ’590 patent”), U.S. Patent No. 7,206,587 (“the ’587 patent”) and U.S. Patent No. 7,848,439 (“the ’439 patent”)(“the Asserted Patents”). The remaining asserted claims addressed in the ID are claims 3 and 4 of the ’590 patent, claim 4 of the ’587 patent, and claims 1 and 2 of the ’439 patent.

³ The Accused Products are identified or described in the ID at iii, xiii, xiv, 1, 30. The Accused Products are also identified in the Parties’ Representative Product Stipulation, Doc. ID No. 688512 (Sept. 18, 2019).

⁴ INVT claimed that the Asserted Patents are standard essential patents or “SEPs.” (*See* ID at 1; 10, 175 n.103.). SEPS are governed by the European Telecommunications Standards Institute (“ETSI”) which is governed by French law. Apple asserted “Breach of FRAND Obligations” as its Seventh Affirmative Defense in its Response to the Complaint and Notice of Investigation (“NOI”) and in the alternative if the Commission were to find that the Asserted Patents are SEPS. (Apple’s Response to Complaint at 47-54

PUBLIC VERSION

The remedies recommended here are limited exclusion orders (“LEO”), with a delayed implementation, and cease and desist orders (“CDO”) that INVT requested against each Respondent.⁵ However, although INVT requested a bond, it is not recommended, even in the alternative, because INVT is a non-practicing entity (“NPE”) that neither makes, distributes nor offers for sale products that compete with the Accused Products. INVT’s analysis of why a bond should issue is flawed and is not recommended. *See* Section IV.C. INVT did not meet its burden of proof with respect to bond.

II. THE PUBLIC INTEREST

A. The Public Interest Legal Standard⁶

The Commission directed that evidence be taken and that finding of facts issue with a recommended determination pertaining to the public interest pursuant to Commission Rule 210.50(b). 19 CFR 210.50(b). (*See* 83 Fed. Reg. at 835.). This recommendation contains an analysis of each of the four (4) public interest factors: (1) the public health and welfare; (2) competitive conditions in the United States economy; (3) production of like or directly

(Doc. ID No. 661735 (Nov. 13, 2018).). HTC asserted “Breach of FRAND Obligations” as its Ninth Affirmative Defense in its Response to the Complaint and NOI. (Doc. ID No. 661734 (Nov. 13, 2018).). ZTE asserted “Breach of FRAND Obligations” as its Ninth Affirmative Defense in its Response to the Complaint and NOI. (Doc. ID No. 661757 (Nov. 13, 2018).). The ID found that the Asserted Patents are not SEPs, and there was no violation of Section 337.

⁵ INVT appeared, mistakenly, to include language for a General Exclusion Order (“GEO”) in a brief heading that recommended “Cease and Desist Orders to Prohibit Respondents’ Circumvention of the Exclusion Order.” (CBr. at 146.). In its use of its word “[C]ircumvention, INVT appears to have confused Cease and Desist Orders with GEOs. (*Id.*). INVT did not provide a rationale with a supporting basis for a GEO, and in fact, requested LEOs.

⁶ Respondents pointed out, correctly that “no party bears the burden on public interest—a party may submit evidence on the issue or it may choose not to, but the ALJ and the Commission must still take public interest into account. As such no party bears any burden.” (*See* RRB. at 66 n. 19 (citing *Certain 3G Mobile Handsets & Components Thereof*, Inv. No. 337-TA-613, Order No. 54, 2015 WL 903652 at *7 (Jan. 22, 2015).).

PUBLIC VERSION

competitive articles in the United States; and (4) the impact on United States consumers. 83 Fed. Reg. 834-35 (Jan. 8, 2018); *see* 19 C.F.R. §§ 210.42(a)(1) (ii)(C), 210.50(b)(1) (2018).

An additional issue is incorporated into this analysis of the public interest. That is: whether, as Respondents argued, if the Commission were to find a violation of 337 and that INVT violated its obligations to offer licenses to Respondents on ‘fair, reasonable and non-discriminatory’ terms (“FRAND”) such that the public interest would bar the Commission from issuing a remedy.⁷ (RPBr. at 63-83; RBr. at 47; *contra* SPBr. at 86-87; SBr. at 81-82).⁸

This is the same argument that Respondents made, one of whom was ZTE, in Judge Shaw’s 800 Investigation that Judge Shaw rejected. *See Certain Wireless Devices With 3G Capabilities and Components Thereof*, 337-TA-800, Recommended Determination at 3-4 (July 8, 2013) (“800 Investigation”).⁹ The specific arguments here also are similar to those the

⁷ Respondents are correct that the Commission has recognized that “FRAND obligation *implicate* the statutory public interest factors.” (emphasis added) (*See* RBr. at 55 (citing *Certain 3G Mobile Handsets and Components Thereof*, Inv. No. 337-TA-613 (Remand), Doc. ID No. 559515 at 4-5 (June 25, 2015)) (“seeking comment ‘on whether, for purpose of the Commission’s consideration of the statutory public interest factors [Complainant] has in effect asserted that the patents in question are FRAND-encumbered, standard-essential patents.”)(“*Certain 3G Mobile Handsets*”).). However, the document in question was a Federal Register Notice that only asked the parties to brief the question and gave notice that the Commission would review, *inter alia*, the public interest after the Commission had received statements from members of Congress, corporations, the Federal Trade Commission and others following a solicitation on public interest factors. *See* 80 Fed. Reg. 37656-658, 659 (July 1, 2015.). The Commission Opinion that issued did not consider substantively the public interest despite the Commission’s solicitation for statements on the public interest. In its Opinion, the Commission stated that because it had not found a violation of section 337 “and therefore need not substantively consider the public interest, the Commission denies Respondents’ motion as moot.” *See Certain Mobile Handsets*, Commission Op. at 50 (Sept. 21, 2015)(Public Version); *see id.* at 50 n. 27 (“Our findings of noninfringement render any consideration of public interest issues moot...).

⁸ All abbreviations in this document are the same as those used in the ID. (*See* ID at xi-xiii).

⁹ Judge Shaw found, as is recommended here, that the Complainant did not prevail in proving a violation of Section 337 by the adjudicated Respondents. Here, as in *800 Investigations*, Respondents did not prevail on their equitable/FRAND defenses. *See 800 Investigation*, Initial Determination at 1 (June 28, 2013). The Commission did not discuss Judge Shaw’s FRAND Findings because the Commission affirmed Judge Shaw’s primary findings that there was no violation of Section 337. (*See 800*

PUBLIC VERSION

Respondents made in the *800 Investigation*, one of which is that a violation of FRAND principles would *per se* preclude the issuance of a remedy.

Respondents' argument does not support a finding that a remedy is contrary to the public interest even if the Commission overturns the finding of the ID that there is no Section 337 violation. (*Accord* SBr. at 86 n.26 and 27.).

Apple's primary expert on the public interest, Dr. Jeffrey Eisenach,¹⁰ did not render an opinion on whether FRAND relates to the public interest. Neither did HTC's or ZTE's expert, Dr. Mario Lopez.¹¹ (*See* n.13, *infra.*) Dr. Eisenach testified:

- Q. In reaching your opinion, you did not consider whether INVT has complied with its FRAND obligations under ETSI IPR policy, is that right?
- A. That's correct.
- Q. And that's because none of the four prongs of the public interest test consider whether INVT has complied with its FRAND obligations?

Investigation, Commission Op. at 1-2 (Dec. 20, 2013.);see also, ID at iii, iv, 2, Sections VII and VIII.)

¹⁰ When he testified during the Hearing on September 20, 2019, Dr. Jeffrey Eisenach was both a Managing Director and Co-Chair of NERA, an Economic Consulting Firm, while he also is a Visiting Scholar at the American Enterprise Group, and an Adjunct Professor at George Mason University School of Law. Dr. Eisenach holds his Ph.D. in economics from the University of Virginia, and a B.A. in economics from Claremont McKenna College. (*See* Ex. 3 to RPS; see also Tr. (Eisenach) at 2262:19-2263:25.). Respondents called Dr. Eisenach to testify on the "effect of the proposed exclusion order on the public interest factors under Section 337, and also looked at the balance, if you will, between the Commission's purpose in protecting intellectual property and incentivizing innovation on the one hand and the relief in this matter on the other." (Tr. (Eisenach) at 2264: 11-17.).

¹¹ Dr. Mario Lopez testified during the Hearing for Respondents HTZ an ZTE on September 20, 2019. At the time of the Hearing, Dr. Lopez was employed at Edgeworth Economics, a company that advises on economic and financial matters. (Tr. (Lopez) at 2159:16-22.). He was called to testify "as an expert witness in the field of economics, patent valuation and remedies relating to FRAND." (*Id.* at 2161:20-23.). He also was called to testify on the public interest.

PUBLIC VERSION

A. I didn't reach that conclusion. I just didn't have an opinion on FRAND.

Q. So you didn't render an opinion on FRAND in this investigation as to the public interest.

A. That's correct.

(Tr. (Eisenach) at 2302:16-2303:5.).¹²

In sum, Respondents' argument on their claimed, interwoven relationship between FRAND and the public interest, and that a violation of FRAND principles bars an exclusion order, is attorney argument in this case that is not supported by expert opinion. Moreover, there is no Commission precedent that supports Respondents' argument. (*See* Sections III.A. and

¹² Dr. Eisenach agrees philosophically with the principles applied in this recommendation: that "from an economic perspective, it is appropriate to balance any public interest harms from an exclusion order against public interest benefits, including the effects of protecting intellectual property rights on *incentives for innovation*." (emphasis supplied). (*See* Expert Report of Jeffrey A. Eisenach, Ph.D. ("Eisenach Rept."), at 4. (Jan. 25, 2019); *see also* Tr. (Eisenach) at 2296:21-2297: 23.).

Dr. Eisenach does not seem to recognize the proposition that in appropriate cases, on appropriate facts, with appropriate evidence, that an exclusion order can be a spur to innovation. Yet the Commission does recognize that adaptation and design arounds can encourage innovation. Historically, the Commission has encouraged design-around. *See, e.g., Baseband Processor Chips and Chipsets, Transmitter, and Receiver (Radio) Chips, Power Control Chips, and Products Containing Same, Including Cellular Tel. Handsets*, Inv. No. 337-TA-543 (Oct. 1, 2011) ("[R]espondent might simply design around the infringed patent without complainant gaining any sales. This result is anticipated by the statute, not discouraged."); *TiVo Inc. v. EchoStar Corp.*, 646 F.3d 869, 883 (Fed. Cir. 2011) ("[L]egitimate design-around efforts should always be encouraged as a path to spur further innovation.").

In *Certain Mobile Electronic Devices and Radio Frequency and Processing Components Thereof*, Inv. No. 337-TA-1065, Initial Determination (Sept. 2018) ("*1065 Investigation*"), in response to the Commission's Question A, asking Apple how long it would take Apple to design around claim 1 of the '490 patent that was found to infringe, Apple filed "Respondent Apple Inc.'s Written Submission Regarding the Commission's Questions On The Issues Under Review, And On Remedy, Bonding And The Public Interest." Apple informed the Commission that it changed its software system (iOS) to remove the accused functionality. (Doc. ID No. 666275 at 29 (Feb. 7, 2019.). Apple's notice of its design around was submitted within five (5) months of the issuance of the Initial Determination. Perhaps Apple would be able to similarly, with the same speed, also engineer a design around if infringement of the Commission were to overturn the findings of the ID in this Investigation.

III.B., *infra.*).

In reaching a conclusion that the public interest factors would not preclude the issuance of a remedy, this recommendation relied upon concrete evidence to the extent it was available, rather than on speculative evidence. *See, e.g. Certain Wireless Devices with 3G and 4G Capabilities and Components Thereof*, Inv. No. 337-TA-868, Order No. 84 at 4 (Dec. 18, 2013)(“the public interest inquiry into the moral worthiness of a complainant to receive relief, and “must be tethered to the four statutory factors.”).

B. Three of the Four Public Interest Factors Would Not Preclude the Issuance of an Exclusion Order

1. An Exclusion Order Would Not Have an Adverse Impact on the Public Health or Welfare

Apple offered some evidence and argument that “public health and welfare” considerations weigh against remedial relief pursuant to 19 U.S.C. § 1337(d)(1). (*See* RBr. at 47; *see also* SBr. at 83.).¹³ Apple’s primary expert witness on the public interest, Dr. Eisenach,¹⁴ testified that the public health and welfare would be implicated because a “robust ecosystem of healthcare and education sectors has been built on Apple’s iOS software.” (RPBr. at 62 (citing

¹³ Respondents, whether collectively or individually, failed to make a specific argument about the public health and welfare factor in their Post-Hearing Brief despite having discussed the “Public Health and Welfare” factor in their Pre-Hearing Brief and Dr. Eisenach’s likely testimony based upon his expert report. (RPBr. at 62.). Accordingly, Respondents have waived any argument on the Public Health and Welfare factor for appeal purposes pursuant to Ground Rule 10.2. INVT and Staff discussed the Public Health and Welfare factor in their Pre-Hearing and Post Hearing Briefs in which they cited evidence and Commission precedent. (CPBr. at 94-95; CBr. at 2, 12-143; SPBr. at 84-85; SBr. at 83.). INVT’s and Staff’s arguments are given great weight because they are supported by Commission precedent.

¹⁴ Dr. Eisenach provided his public interest testimony during the Hearing only on behalf of Apple but not on behalf of ZTE or HTC. The following exchange occurred between INVT’s counsel and Dr. Eisenach: “Q. ... Your opinion is that an exclusion order would cause public interest harm; is that right? A. That’s correct. Q. And today you’re only rendering an opinion on behalf of Apple, correct? A. I think that’s right.” (Tr. (Eisenach) at 2302:4-10.).

PUBLIC VERSION

Eisenach Rpt. at ¶¶ 118, 120 (RX-1360.2-3.)). Surely, the health and welfare would be *implicated*, but not to the extent of precluding an exclusion order.

Specifically, Dr. Eisenach extolled the virtues of the of the Apple iOS-based technology platform that hospitals and educational institutions use, along with mobile apps that many prestigious hospital systems have developed to access health records. (*See* RPBr. at 62 (citing Eisenach Rpt. at ¶¶ 109-111; RX-0811; RX-0812; RX-0882; *see also, id.* (citing RX-0894 which discusses Johnson & Johnson heart monitoring study using Apple Watch)). While the virtues of Apple products are recognized frequently and widely, Dr. Eisenach conceded during the Hearing that iPhones and iPads and the other Accused Products such as smartwatches, are not medical devices. (*See* Tr. (Eisenach) at 2303:6-9.). Dr. Eisenach focused most of his argument and testimony on the other three (3) public interest factors to argue that a remedy would “devastate” “competition and innovation” and cause harm to American consumers because “[L]ike or “[D]irectly competitive products are not manufactured in the United States. (RBr. at 48-50.). With respect to that broad statement, that is not true with respect to the public health and welfare, or, for that matter, any of the other public interest factors.

INVT’s expert witness, Dr. Ryan Sullivan, offered certain opinions that were contrary to Dr. Eisenach’s but that generally hued to Commission precedent. Dr. Sullivan testified that he did not see evidence that the Accused Products are essential for public health.¹⁵ (*See* CBr. at

¹⁵ When he first testified during the Hearing on September 17, 2019, Dr. Ryan Sullivan served as president of a consulting firm called Intensity, where he is an economist. (Tr. (Sullivan) at 1128: 14-16; *see also* CX-1296.). Dr. Sullivan submitted an expert report that challenged each of the three (3) Respondents, and three (3) rebuttal reports, for a total of six (6) reports. (*Id.* at 1129: 6-11.). Dr. Sullivan holds a B.A, an M.A. and a Ph.D. in economics from the University of California, San Diego. (*Id.* at 1130: 3-7.). INVT called Dr. Sullivan as in expert in economics of intellectual property, including patent licensing. (*Id.* at 1132: 3-6). Specifically, Dr. Sullivan was asked to testify with respect to FRAND obligations, to evaluate the potential effects of remedies on the public interest, and to evaluate an appropriate bond amount. (*Id.* at 1133: 2-11.).

PUBLIC VERSION

142 (citing *Tr. (Sullivan)* at 1244:8-25; *id.* at 1244:8-21 (referencing Respondents' claim that the public health and welfare require Apple iOS devices specifically for the public health and welfare: "there are other devices that can be used to satisfy those requirements"))).

Staff and INVT noted that in previous Commission investigations, even Apple has represented to the Commission that electronic mobile devices "do not have any specialized public health, safety or welfare applications, nor are they the types of products that affect public health and welfare." *Certain Electronic Digital Media Devices and Components Thereof*, Inv. No. 337-TA-796, Apple Inc.'s Submission on Remedy, Bond, & Public Interest (June 11, 2013)) at 19; *see also Certain Personal Data and Mobile Communications Devices and Related Software*, Inv. No. 337-TA-710, Apple Public Interest Statement (Aug. 25, 2011)) at 2 ("the infringing HTC products [smartphones] do not implicate any particular public health, safety, or welfare concerns.")("*Certain Personal Data*").

HTC's and ZTE's expert witness on the public interest, Dr. Lopez, offered only one general, conclusory sentence on the public interest, albeit one that was in line with Dr. Eisenach's overarching opinion.¹⁶ Dr. Lopez's statement was unsupported and is given little weight. He did not provide specific, supported testimony on the specific health and welfare factor or any of the other factors.

There is no reason to reach a different result from the arguments Apple has made

¹⁶ Dr. Lopez was asked only if he had reached any opinion whether "an exclusion order in this investigation would negatively impact the public interest." (2193:16-24.). Dr. Lopez's sole opinion on the public interest consisted of the following: "Q. And would the impact of an exclusion order be limited to Respondents? A. No, no, it wouldn't. In the event there could be competitive effects for consumers by removing low price phones, by removing products that are differentiated from the market that could result in loss of consumer welfare." (Tr. (Lopez) at 2194: 11-18.).

previously with respect to smartphones and similar devices, such as tablets and smart watches despite Apple's at times, inconsistent positions.¹⁷ There is no reason to deviate from Commission precedent in which a remedy typically follows a violation of Section 337.

Given the lack of direct, concrete evidence that would explain how the public health and welfare in the United States specifically would be affected negatively, or even seriously compromised by a LEO, it is a finding that neither the issuance of a LEO nor a CDO would have an adverse effect on or even compromise the public health and welfare. This finding comports both factually and legally with recent Commission opinion.

2. An Exclusion Order Could Have an Adverse Impact on Competitive Conditions in the U.S. Economy but Not to the Extent of Precluding an Exclusion Order

a) Overview

Apple argued that current and *future* cellular products would be implicated if the Commission were to find a violation of Section 337, because “by definition a standard-essential patent has no non-infringing alternatives.” (RBr. at 48.). HTC and ZTE were left out of this remarkable and only partially accurate statement. Part of the statement is true. The current, but not necessarily future cellular products would be implicated. For example, as 5G smartphones and other 5G products incorporate 5G standards, they would not necessarily be affected by an exclusion order.

Despite a glaring heading in Respondents' Brief that an “Exclusion Order Would

¹⁷ See e.g. *Certain Mobile Electronic Devices and Radio Frequency And Processing Components Thereof (II)*, Inv. No. TA-337-1093, Analysis And Findings With Respect To The Public Interest, And Recommendation On Remedy And Bond, at 21-24. (April 15, 2019)(Unreviewed)(“*Certain Mobile Devices II*”).

PUBLIC VERSION

Devastate Competition and Innovation in the Premium Smartphone and Mobile Operating System Markets,” neither Dr. Eisenach’s analyses nor the weight of the evidence supports the conclusions in Respondents’ section heading. (RBr. at 47.).

INVT argued, generally successfully, with concrete evidence, that Respondents’ conclusions were wrong for three (3) reasons: (1) there are numerous “reasonable” substitutes for Respondents accused mobile devices thereby “diminishing any potential harm from exclusion;” (2) none of the four public interest factors weigh against possible relief because Respondents failed to demonstrate any “concrete and specific harm;” and (3) Respondents could avoid any alleged disruption or negative impact from an exclusion order by engaging “in bilateral negotiations and ultimately consummate[ing] an agreement with FRAND royalties.” (CBr. at 140-141 (citing 83 Fed. Reg. 834-835 (Jan. 8, 2018); 19 C.F.R. § 210.42 (a)(1)(ii)(C), 210.50(b)(1)(2018); *see also* Tr. (Sullivan) at 1245:1-9.).

Ultimately, both Dr. Eisenach and Dr. Sullivan agreed that market competition in the United States is “dynamically competitive” in which new models are continually available in the marketplace. (Tr. (Eisenach) at 2308:17-19; Tr. (Sullivan) at 1242;5-7.). Dr. Eisenach also acknowledged that that there is “extensive market” differentiation in both markets,” referencing both the “premium” smartphone market and the lower tier market. (*Id.* at 2266:4-2267: 20.).

Although neither HTC nor ZTE offered expert opinion evidence on this factor, HTC’s and Apple’s fact witnesses did. [REDACTED]

[REDACTED] (See CBr. at 141 (citing CX-1565C, Dep. (Newby-House)(an HTC fact witness) at 19:4-20:25; CX-1569 Dep. (Jaynes)(an Apple fact witness) at 66:10-18 (“ [REDACTED] ”); CX-1569C Dep. (Wood)(a ZTE fact witness) at 33:21-34:3 (there are “ [REDACTED]

_____”). Dr. Sullivan identified specific products available in the United States that are supplied by “Samsung, LG, Motorola, OnePlus, Google, Nokia, ASUS, Alcatel, TCL and others. (Tr. (Sullivan) at 1243:3-14.). Dr. Sullivan noted that these products have “different features and functionalities, different bells and whistles, yet they are all beautiful smartphones that are available to consumers.” (CBr. at 141 (citing Tr. (Sullivan) at 1241:10-13.).

b) Apple Relied for Its Analysis of Market Conditions Within the U.S. Economy and Harm to Consumers on Fundamental Economic Principles That as Applied, Were Flawed

To support its analysis, although not precisely in this order, Apple drew upon Dr. Eisenach’s analysis of competitive conditions in the U.S. economy. Dr. Eisenach’s overarching opinion was that an exclusion order would cause “[H]arms” that “would be too significant.” (Tr. (Eisenach) at 2264:24-2265:25.). He testified that an exclusion order would “create a virtual monopoly” on premium smartphones and an “actual monopoly” in the mobile operating system market in the United States. (Tr. (Eisenach) at 2265:15-20.). Dr. Eisenach claimed that an exclusion order would harm Apple’s U.S. suppliers, and more broadly, Apple’s participation and investment in the U.S. economy. (*Id.* at 2265:20-23.). He estimated the harm to U.S. consumers at _____ annually. (*Id.* at 2265:10-14; 2285:23-2286:6; RDX-0019C.0015.).

To reach his conclusions, Dr. Eisenach divided the market for smartphone devices hardware, and the market for operating systems, mobile operating systems.” (Tr. (Eisenach) at 2266: 20-2267:3; 2266:6-9.). Based upon price and features (the latter of which he did not discuss with any specificity Dr. Eisenach then divided “the market” yet again into a binary marketplace structure of “premium” smartphones comprised of Apple and Samsung, and the all

PUBLIC VERSION

the rest, i.e. “lots of other models of Motorolas and ZTEs¹⁸ and so forth which don’t compete directly with the premium smartphone.” (*Id.* at 2267:20-2268:5.).

Dr. Eisenach testified, but without attribution to sources, that there is a “consensus” within the “economic community” and in the “antitrust community” that this is how the marketplace is divided. (*Id.* at 2289:16-2290:5.). Dr. Eisenach’s price differentiation of Apple and Samsung as one group from all other smartphones as another group, was defined as those smartphones above [REDACTED] and those below [REDACTED]. For that definition, Dr. Eisenach referenced a 2017 study by a company called IDC. (Tr. (Eisenach) at 2290:6-12; 2307: 20-2308:3; RX-862.).¹⁹ Dr. Eisenach’s statement may be true. However, he did not offer supporting evidence on why the marketplace should be divided as he did, or how IDC evaluated the market using the referenced price divide. He simply testified, *ipse dixit*, that it is.

As part of his price differentiation, Dr. Eisenach only graphically compared the iPhone XS, with 64GB+ of storage and an A12 Bionic chip that sold at the time he testified for \$999.00 with the Samsung Galaxy S10 with 128GB+ of storage and an Octa-Core Processor that sold for \$899.00. (*See* RDX-0019C.0004.). For his lower priced models that he claimed do not compete

¹⁸ Effectively, Dr. Eisenach relegated ZTE and HTC products to a lower tier of smartphones and smart devices, apparently primarily based on price only because he never explained which features HTC’s or ZTE’s Accused Products lack that place them in the lower tier of smart devices and not in the “premium” market he claimed is occupied only by Samsung and Apple.

Moreover, as part of his “ecosystem” differentiation between Android operating systems and Apple’s iOS operating system, Dr. Eisenach failed to explain what exactly differentiated Samsung’s Android based smartphones and smart devices and from ZTE’s and HTC’s Accused Products.

¹⁹ Dr. Eisenach’s Expert Report took his price differentiation for [REDACTED] phones and lower priced phones from a study he did not reference during the Hearing but which he did reference in his expert report. (*See* Eisenach Rept. at 19 n.55 (citing *IDC Quarterly Mobile Phone Tracker: 2017Q4 Historical Release* (Feb. 9, 2018 (APL-INVT-ITC_06618648)).).

PUBLIC VERSION

with Apple iPhones or Samsung Galaxy smartphones, Dr. Eisenach graphically compared only an HTC Moto G7 Play smartphone with 32GB of storage that sold for \$199.00, and a ZTE Z432 Feature Phone with a smaller screen that sold for approximately \$30.00 (*Id.*). He did not offer any other examples to explain why Apple iPhones and Samsung smartphones are “top tier” as opposed to other manufacturers’ smart devices that may contain many of the same features at a much lower price.

Dr. Eisenach did not testify about or attempt to show the distribution of available of comparable or competitive models throughout the marketplace at different price points. It also was not exactly clear how the division between smartphones prices above [REDACTED] and those below [REDACTED] was made. Dr. Eisenach’s 2017, IDC marketplace analytics merely showed in gross terms the numbers of “Premium Smart Phone Market (Units 2017)” in which Apple then had [REDACTED] of the marketplace, Samsung had [REDACTED], and all others, consisting of Google, LG, Motorola, HTC, ZTE and “other” comprising the remaining [REDACTED]. (*See Tr. (Eisenach) at 2289: 20-2290: RDX-0019C.0016.*)

INVT observed, correctly, that Dr. Eisenach’s analysis did not consider that Apple sells iPhones for less than [REDACTED]. (CRBr. at 24.). Dr. Eisenach did not discuss how Apple iPhone prices are discounted as they age and are replaced by newer models. Dr. Eisenach also did not discuss in his testimony or factor into his calculations or modeling the percentage of Apple iPhones that cost more than [REDACTED] and those that fall below [REDACTED] with the rest of the phones that are available from various companies.

Dr. Eisenach observed that there is another product differentiation in the marketplace between Samsung’s (and others’) Android operating system and the Apple iOS operating system

PUBLIC VERSION

which are not inter-operable with one another. (Tr. (Eisenach) at 2268: 6-19.).²⁰

As part of his analysis, and to support his opinion that consumers would be harmed to the tune of [REDACTED] annually, Dr. Eisenach looked at randomized survey data [REDACTED]

[REDACTED] who were Apple iPad, iPhone and watch users. The [REDACTED] who participated in the surveys were asked if [REDACTED]

[REDACTED] (See RX-106C-108C.). Dr. Eisenach testified that [REDACTED] of iPhone customers and [REDACTED] of iPad purchasers [REDACTED]

[REDACTED].²¹ To Dr. Eisenach, that indicated that [REDACTED]

[REDACTED]

[REDACTED]

[REDACTED] (Tr. (Eisenach) at 2270: 1-2272:16; RX-106C-RX:108C; 2272: 22-2273:18; 2274:2275:23 ([REDACTED])).

As is described in more detail below, Dr. Eisenach’s analysis, here, and below was flawed. With respect to this aspect of his analysis, Respondents described the [REDACTED]

[REDACTED] (RBr. at 26.). However, [REDACTED]

[REDACTED]

Because of such Apple “brand loyalty,” which undoubtedly exists, and the limited interoperability between Android operating systems and Apple iOS systems, Dr. Eisenach relied primarily upon an academic economic study that deals with “switching costs” or the costs to

²⁰ In his expert report, Dr. Eisenach cited metrics that Android operating systems comprise [REDACTED] of the U.S. market and [REDACTED] of the global market in 2017 while Apple’s iOS system served [REDACTED] of the U.S. market in 2017 and [REDACTED] of the global market. (See Eisenach Rpt. at 46, citing IDC, *Quarterly Mobile Phone Tracker*, 2017Q4 Forecast (Feb. 23, 2018)(APPL-INVNT-ITC_005592220).)

²¹ There is a mistake in the transcript. The [REDACTED] refers to iPad customers.

PUBLIC VERSION

consumer of jettisoning one product and switching to another. In this case, “switching costs” would occur if Apple Accused Products were withdrawn and consumers were forced to replace their products with Android system products (or theoretically, vice versa). (Tr. (Eisenach) at 2275: 23-2277: 7; RDX-19C.8; RX-276 at 7-8.). However, the empirical data that Dr. Eisenach used was taken from the South Korean market, not the U.S. market.²² The principle of switching costs is a fundamental economic principle; the data Dr. Eisenach used were not fully explained and incomplete.

To calculate his estimated [REDACTED] damage to consumers in the United States, Dr. Eisenach created what he described as “consumer surplus” in relation to a “demand curve” using certain data for the [REDACTED]. As he defined it, consistent with basic academic principles, “consumer surplus is simply the difference between [a consumer’s] willingness to pay and what was paid by each consumer” which in some sense also measures the “elasticity of demand” or again, what a consumer is willing to pay. (Tr. (Eisenach) at 2278:1-2281-4.).

Without explaining all of his mathematics, but in explaining the steps he used, Dr. Eisenach used the “Lerner Index,” a standard economic equation which demonstrates a direct relationship between profit margins and demand elasticity,²³ or how consumers might respond to

²² During his testimony, Dr. Eisenach only identified the study as by “Park and Koo.” The study is referenced in Dr. Eisenach’s Expert Report as “An Empirical Analysis of Switching Cost in the Smartphone Market in South Korea,” Telecommunications Policy 40 (2016) 307-318 at 309. (See Eisenach Rpt. at 36 n.100.).

²³ Dr. Eisenach used “elasticity of demand,” a common economic measure of how sensitive consumer demand is in relation to supply or price, or other economic changes to help explain his “estimated” consumer demand curve and “estimated harm” to consumers, using the Lerner Index. Dr. Eisenach did note in his Expert Report that “the Lerner Index holds strictly only for a single-product firm. For a multiple product firm, the relationship between the elasticity and the Lerner Index value depends on whether the multiple products firm sells are substitutes or complements in demand.” (See Eisenach Rpt. at 37 n.107.). He defined “elasticity of demand” as the “lower the elasticity of demand, the higher the price, the profit margin the firm can charge.

PUBLIC VERSION

a product's change in price either because of changes in demand or supply availability or other economic conditions. (*Id.* at 2279: 1-2281-24.).²⁴

For his data, Dr. Eisenach used Apple [REDACTED] from Apple's FY 2018 internal cost and sales data only for the [REDACTED] (and not all Accused Products) which suggested that on those products there were [REDACTED]. Using those estimates and actual data on average revenue for those same iPhones, Dr. Eisenach estimated the average consumer's willingness to pay between [REDACTED].²⁵ By subtracting the estimated average selling prices for each of the iPhone models, Dr. Eisenach estimated that an average iPhone user would have lost (as consumer surplus or "switching costs") some [REDACTED] if the [REDACTED] iPhone models, respectively were not available during Apple's FY 2018.²⁶ To calculate his [REDACTED] in "harm" to consumers, Dr. Eisenach used Apple's internal sales data for the total number of units sold of [REDACTED] of the [REDACTED] iPhone models which he multiplied by the consumer surplus or average "switching costs" of [REDACTED] he estimated for each unit of the [REDACTED] models he used for his calculations. However, as with other aspects of his calculations and analyses, he did not always explain the source of his data, or the assumptions he used in his calculations.

So if demand is very inelastic, I can raise the prices a lot and not many people will go to other thing, hence, I have a big margin." (Tr. (Eisenach at 2280:7-2281:17.).

²⁴ Dr. Eisenach also used the "Herfindahl-Hirschman Index," which he described as a "commonly used measurer of market structure which economists believe is, other things being equal, associated with market performance, which is to say prices." (Tr. (Eisenach) at 2291: 6-11.). He also described it as "market shares squared." (*Id.* at 2291:14-17.)

²⁵ Dr. Eisenach did not fully explain how he derived these numbers during the Hearing.

²⁶ Eisenach Rpt. at 37-39.

c) Problems with Apple’s Methodology Render Certain Evidence as Incomplete or Inconclusive

On cross-examination, INVT simply, but effectively, challenged Dr. Eisenach’s methodology for calculating harm to the U.S. economy and consumers, and particularly, his [REDACTED] calculation.

As a part of his evaluation of the elasticity of demand for the [REDACTED] iPhone models he considered using 2017 data, Dr. Eisenach agreed that that he had “assumed” a shape for the demand curve he offered. (Tr. (Eisenach) at 2303:10-19; *see also* RDX-0019C.0009 (referencing RX-0805.11)). Dr. Eisenach initially equivocated that he “looked at evidence,” (i.e. the Lerner Index and certain academic or previous studies using old data that was limited to only three iPhone models). He acknowledged that the he had *not* performed an empirical analysis to demonstrate “that the assumption of constant elasticity of demand is applicable to the demand for Apple iPhones.” (*Id.* at 2303:21-24; 2304: 6-10.).

Stated another way, importantly, Dr. Eisenach acknowledged that his analysis did not include or consider a demand curve that *included* an actual calculation of how consumers would react if they were forced to obtain different smartphones or other smart watches or tablets, and therefore, what the true “switching costs” or “consumer surplus” would be if he had created a demand curve that included the supply side, i.e. a calculation of what consumers would actually pay for alternative products available to consumers. (Tr. (Eisenach at 2307:14-19; *see also* CRBr. at 27.). With respect to Dr. Eisenach’s “elasticity of demand” curve, Dr. Sullivan’s critique was accurate. To estimate a demand curve reliably is complex that requires “sales data from all entities across time, including what their marginal costs are” and the task [of] undertaking it would be thousands of hours.” (Tr. (Sullivan) at 1351:17-1352:16.). Dr.

PUBLIC VERSION

Eisenach's demand curve was based on assumptions without reliable or even approximately useful data.

Similarly, Dr. Sullivan's critique that Dr. Eisenach's "switching cost" figures were overstated is valid. Dr. Sullivan testified that an exclusion order would cause switching costs only in the short term. (Tr. (Sullivan) at 1319:3-11.). Dr. Sullivan also observed (as discussed above) that switching costs would be quickly overcome in the long term by innovation and competition, and even by the possibility of offsets from significantly lower-cost substitutes. (Tr. (Sullivan) at 1241:14-1242:3, 2544:23-:2545:9.). While Dr. Sullivan suggested that the effects of switching would set in quickly, it was unclear how long it would take for the switching costs to be absorbed. Nonetheless, even Dr. Eisenach agreed with Dr. Sullivan that switching costs would be offset by competition and innovation and the emergence of new products. (Tr. (Eisenach) at 1241:14-1242:24.). Moreover, Dr. Sullivan explained that a vacuum in the marketplace caused by an exclusion order, that in turn causes switching costs, will be filled "very, very quickly...[w]hether it be one week or one month...it's on the order of magnitude given the ability of what's already in production." (See CBr. at 146 (citing Tr. (Sullivan) at 2544:23-2549:9.). For that proposition, Dr. Sullivan relied upon William Nordhaus, the 2018 Nobel prize winner in economics, for the proposition that "most of the benefits of technological change are passed on to consumers rather than captured by producers. (CBr. at 146 (citing CDX-00006C-0098; Tr. (Sullivan) at 1241:14-1242:21).).

Also problematic in Dr. Eisenach's testimony about "switching costs" was his use of certain [REDACTED] survey data on its [REDACTED] to the Apple ecosystem to imply that Apple users would not want to or be willing switch to Android devices if forced to do so. (Tr. (Eisenach) at 2270:1-2272:16; RDX.0019C.0005, 0006, 0007 citing RX-106-RX:108;

PUBLIC VERSION

2272:22-2273:18; 2274:2275:23.). He appeared to use Apple's customers' [REDACTED] to Apple products as a "proxy" for what Apple's customers *would* do if forced to switch. However, [REDACTED] [REDACTED] (See RX-106C-RX-108C; RDX-0019C.0005-019C.0007.). Therefore, there was no information on whether Apple's customers might find willingly find substitutes to the top priced Apple products at a lower cost and with similar features that might reduce, if not eliminate, switching costs.

Moreover, Dr. Eisenach's demand curve and consumer surplus figures did not include any other Accused Products than the [REDACTED]. He left out data or information with respect to how the exclusion of other Apple products, including [REDACTED] and other models might affect consumer surplus. He did not consider the discounting effects of [REDACTED] on consumer surplus. Accordingly, Dr. Eisenach's testimony on his "demand curve" and "consumer surplus" figures were incomplete.

INVT also challenged Dr. Eisenach's binary segmentation of the top-tier market between Apple and Samsung that would leave Samsung as a "virtual monopoly" if Apple's Accused Products were subject to an exclusion order. (Tr. (Eisenach) at 2308:4-9.). That may be partially accurate, even if based on limited data. For example, of the approximately 40 million 3G and 4 LTE smartphones sold in the United States during the third quarter of 2018, Samsung had a 25.8% share, LG had a 14.9% share, LG had a 14.9% share, Motorola had a 7.9% share and TCL had a 4.5% share. (See CX-0723.). Dr. Eisenach testified that an exclusion order would lead to a reduction in Apple's market share from approximately [REDACTED] while Samsung's market

PUBLIC VERSION

share would increase from [REDACTED] (Tr. (Eisenach) at 2294:11-20; *see also* RDX-0019C.10).²⁷ Again, he estimated a binary marketplace. INVT criticized Dr. Eisenach’s use of the HHI because while Dr. Eisenach theorized, without data, that if Apple Accused Products were to be excluded from the U.S. marketplace, that would, also according to Respondents’ argument, lead to sustained price increases. (CRBr. at 25 (citing RBr. at 49); *see also* RX-0176.). INVT also criticized Dr. Eisenach’s use of the HHI because he took it from the Department of Justice and the Federal Trade Commission’s policy guidelines on “mergers and acquisitions involving potential competitors (‘horizontal mergers’).” (CRBr. at 24 (citing RX-0176.0001.)). INVT also noted that the publication from which the HHI was taken warned that the “guidelines are *not* intended to describe how Agencies analyze cases other than horizontal mergers.” (emphasis supplied) (CRBr. at 25 (citing RX-0176.0001.)). Again, Dr. Eisenach may have used a correct economic principle, but not necessarily in the correct context and without any data support for his estimate beyond very general information.

Dr. Eisenach acknowledged that the mobile device market is “dynamically competitive” and fosters innovation, and that there are a variety of other smartphones with different characteristics available in the market. (Tr. (Eisenach) at 2308:10-2309: 1.). He called Samsung’s products “not comparable” largely because they were not part of the Apple ecosystem and he did not consider them to be “reasonable” substitutes. (*Id.* at 2308:20-2309:1.).

Dr. Sullivan challenged Dr. Eisenach’s “virtual monopoly” opinion. Dr. Sullivan pointed out that Samsung might not increase its market share, but rather other competitors such as

²⁷ In the context of his discussion of market concentration, and the effects of giving Samsung, specifically more market power if Apple Accused Products were excluded from the United States, Dr. Eisenach used the “Herfindahl-Hirschman Index,” (“HHI”) to describe the U.S. marketplace after an exclusion order as a “highly concentrated market.” (Tr. (Eisenach) at 2290: 2294-25.).

PUBLIC VERSION

Google, LG, Motorola, TCL, Blackberry, Alcatel, Asus and others would not only be competitive, but also might increase their share of the market in relative to proportion to replace Apple products. (Tr. (Sullivan) at 1240:3-18, 1243:3-14; CDX-006C-0096; CX-0723.).

Ultimately, Dr. Eisenach's estimate of [REDACTED] in consumer harm if an exclusion order were to issue was not supported by clear evidence, current data, or empirically based calculations. There clearly would be switching costs if Apple's Accused Products (or the HTC and ZTE Accused Products) were to be excluded, but it is not clear based upon the analyses provided, just how large quantitatively that harm would be.

Whether or not products are "comparable," the fact is there is a wide variety of product substitutions if an exclusion order issues here. Unlike in the cases cited below, there has not been a case since the 1980's in which the Commission has found a violation of Section 337 without issuing an exclusion order. In the cited cases, below, there were no substitutions available for the products excluded. (*See* CBr. at 153 n.24 (*citing Certain Automatic Crankpin Grinders*, Inv. 337-TA-60 (Dec. 1979); *Certain Inclined-Field Acceleration Tubes & Components Thereof*, Inv. No. 337-TA-67 (Dec. 1980); *Certain Fluidized Supporting Apparatus & Components Thereof*, Inv. No. 337-TA-182/188).).

d) An Exclusion Order Would Have an Adverse Impact on Apple's Suppliers and App Developers and Could Have an Adverse Impact on Apple's U.S. Workforce

Dr. Eisenach provided un rebutted and unchallenged evidence, that in 2018, Apple spent some [REDACTED] in the United States to support some 9,000 United States-based component suppliers and companies that resulted in Apple's support for some 450,000 jobs. (Tr. (Eisenach) at 2295: 12-24; RDX-0019C.0022, citing RX-1379.2.). According to Dr. Eisenach's data, Apple's support monetarily in the workforce represented a [REDACTED] increase over the previous year.

(*Id.*). Additionally, according to Dr. Eisenach’s un rebutted and unchallenged evidence, in 2018 Apple added some 6,000 jobs to its U.S. workforce and as of the Hearing, employed some 90,000 people in all 50 states. (*Id.*, 2295: 1-25; RDX.0019C.0022, citing RX-0528.2.). Dr. Eisenach testified that based upon Apple’s support for, and direct participation in, the U.S. workforce, an exclusion order could cause Apple’s global revenues to decline by some [REDACTED]

[REDACTED]

[REDACTED]

[REDACTED] (*See* Tr. (Eisenach) at 2296: 6-14.).

While Dr. Eisenach’s conclusions were general, and he did not quantify or use data to support how he arrived at a [REDACTED], or how that decline would flow to Apple’s direct or indirect workforce in the United States, the potential impacts cannot be dismissed out of hand. (The Sections above describe the same types of problems as exist in this estimate.). Nonetheless, if the Commission were to overturn the ID and consider the impact of an exclusion order on Apple’s workforce and its support for its suppliers and developers throughout the American economy, more information would be required from Apple to assess a more quantitatively supported nexus between an exclusion order and Apple wages and jobs.

3. An Exclusion Order Would Not Have an Adverse Impact on the Production of Like or Directly Competitive Articles in the United States

The weight of the evidence supports a finding that that an exclusion order would not negatively affect the production of like or directly articles in the United States. (*Accord*, SBR. at 83; CRBr. at 28-29.). On this factor, Apple produced conclusions, but little evidence. There was a failure of proof that would lead to a finding that an exclusion order would be harmful as Apple argued. As Dr. Eisenach acknowledged, [REDACTED]

PUBLIC VERSION

[REDACTED] (Tr. (Eisenach) at 2295:19-20.). [REDACTED]

[REDACTED] (HTC Resp. to Complaint and NOI at 6; ZTE Resp. to Complaint and NOI at 7.).

In *Certain Mobile Devices II*, Apple also did not dispute that because it does not manufacture in the United States, it has no manufacturing competitors in the U.S. that directly compete with Apple on that basis. (*Certain Mobile Devices II* at 41.). Apple did not offer evidence during the Hearing in this Investigation or in an earlier Investigation involving the same type of proof, that Samsung, or any of Apple’s other competitors, lack the capacity to supply the U.S. market if Apple were to exit the U.S. market. (*See Certain Mobile Devices II* at 25.). Nonetheless, because Apple made the argument, its task was to supply evidence/proof.

By contrast, Dr. Sullivan testified that as worldwide supplier, Samsung, with other suppliers, would have an excess capacity and facilities to replace Apple’s products. (Tr. (Sullivan) at 1243:15-25.). Dr. Sullivan testified only generally that other suppliers who could supplement Samsung’s production would be LG, Motorola, OnePlus, Google, Nokia, ASUS, Alcatel, TCL, and others. Dr. Sullivan did not quantify during his testimony the extent to which each of those companies would or could replace any of the Accused Products. (*Id.* at 1243: 3-14.). Dr. Sullivan also testified that Accused Products subject to a remedy could be replaced within a reasonable time. (Tr. (Sullivan) at 1243:15-1244:7.). Again, he did not provide evidence or support what might be a “reasonable” time.

Overall, although there clearly are potential substitutions for the Respondents Accused Products, the quantification of the time it would take for substitutions to occur or which companies might have specific capacity was neither specific nor satisfying. The best evidence offered, is that no competitive products are produced in the United States, and therefore, there

PUBLIC VERSION

are no comparative manufacturing competitors to Apple, HTC or ZTE in the United States. (*See Certain Table Saws Incorporating Active Injury Mitigation Technology and Components Thereof*, Inv. No. 337-TA-965, Comm'n Op. at 11 (Jan. 27, 2017) (“The Commission typically finds that this factor does not weigh against granting a remedy when the relevant articles are all produced abroad.”).

4. An Exclusion Order Would Likely Have A Negative Impact on U.S. Consumers, But the Extent of Possible Harm Was Not Well Quantified

INVT made the more persuasive argument than did Respondents with respect to how U.S. consumers might be affected by an exclusion order. Staff agreed with INVT’s conclusion that an exclusion order would not adversely impact U.S. consumers based upon both Dr. Eisenach’s and Dr. Sullivan’s (and other) testimony that there are numerous substitutes for the Accused Products. (CBr. at 141-142; SBr. at 83.). Staff and INVT rejected Dr. Eisenach’s [REDACTED] annual harm to consumers. (CBr. at 81; SPBr. 83-86.). While ZTE and HTC did not call fact witnesses to testify during the Hearing on the public interest factors, certain of their fact witnesses were deposed. For example, HTC’s fact witness Mr. Nigel Newby-House testified that [REDACTED]” (*See* CBr. at 141 (citing CX-1565C, Dep. (Newby-House) at 19:4-20:25.)). As INVT noted, Mr. James Ray Wood for ZTE, testified that there are [REDACTED] (CBr. at 141 (citing CX-1569C, Dep. (Wood) at 33:21-34:3.)).

The crux of Dr. Eisenach’s and Apple’s testimony with respect to the quantified harm to consumers is dealt with in Sections II.A. and II.B., *supra*. There is only some merit to the argument that American consumers could be harmed if an exclusion order were to issue because of the “switching costs.” Nonetheless, the extent of the harm to consumers as Dr. Eisenach

PUBLIC VERSION

calculated it was problematic and hardly definitive, for the reasons explained in Sections II.B.2.(b). Similarly, while Dr. Sullivan challenged Dr. Eisenach's calculation of consumer surplus and his elasticity demand curve, Dr. Sullivan, at best, undermined Dr. Eisenach's methodology without quantifying the impact of an exclusion order on consumers. Again, there was insufficient proof on this factor to preclude an exclusion order.

Much of the data supporting the opinions appeared to be speculative or insufficiently thorough to support the opinions.

III. FRAND AND THE PUBLIC INTEREST

A. The Commission Has Articulated Its FRAND Positions That Do Not Support Certain of Respondents' Arguments

Respondents argued wrongly and belatedly in its Post-Hearing Reply Brief that a FRAND violation, *per se*, precludes the entry of an exclusion order. (RRBr. at 70.). INVT and Staff hotly disagreed. The variously called Respondents' argument as irrelevant to the public interest factors, and FRAND obligations are not one of the factors considered. (See SPBr. at 86; SBr. at 83-84; CBr. at 1, 15.). Because Respondents failed to make this argument until its Post-Hearing Reply Brief, they waived their argument for all purposes pursuant to Ground Rules 7.2. and 10.1. (See Order No. 3, Attachment A at 27, 41 (Oct. 23, 2018.). Nonetheless, the argument needs to be addressed because of Commission precedent and INVT's and Staff's arguments.

The Commission has expressed its opinions on the relationships between standard essential patents ("SEPs"), ETSI's IPR Policy,²⁸ the limits and contours of a FRAND defense at the USITC, and the Commission's remedy authority and obligations. See *Certain Electronic Devices, Including Wireless Communication Devices, Portable Music and Data Processing*

²⁸ In *Wireless Communications Devices*, the Commission discusses generally the Standard Setting Organization ("SSO") ETSI at 31, 42 n.8, 43-45.

PUBLIC VERSION

Devices, and Tablet Computers, Inv. No. 337-TA-794, Commission Op. at 45-60 (June 4, 2013)(“*Wireless Communication Devices*”). In *Wireless Communication Devices*, the Commission noted that on appeal, Apple, one of the Respondents in that Investigation, had not cited to any binding legal authority “that the Commission may not investigate a violation of section 337 based on infringement of patents subject to a FRAND undertaking.” See “*Wireless Communications Devices* at 45 (citing Apple Cont. Pet. For Review, 44 (Oct. 1, 2012) (“[T]he ALJ should have held that Samsung was barred from even asserting those claims.”). The Commission rejected Apple’s argument in its response to Apple’s Petition stating “[T]he Commission ‘is a creature of statute, and must find its authority for its action in its enabling statute.’” (See *id.* at 46 (citing *Kyocera v. Int’l Trade Comm’n*, 545 F3d 1340, 1355 (Fed. Cir. 2008.)). The Commission noted that “[T]he Commission and its ALJs have never adopted Apple’s theory that a FRAND undertaking *per se* precludes a Commission determination of violation. See *Wireless Communication Devices* at 46 (citing *Certain Mobile Telephone Handsets, Wireless Communication Devices, and Components Thereof*, Inv. No. 337-TA-578, Order 34, Initial Det., 2007 ITC LEXIS 228 (Feb. 20, 2007)(nonreviewed Mar. 22, 2007)(“*Mobile Telephone Handsets*”). The Commission also observed that if a violation is found, the Commission has the authority to exclude certain arguments that infringe valid and enforceable patents and that there is no distinction between SEPs and other patents. (See *Wireless Communications Devices* at 48, 51-52.).

B. Even a FRAND Violation Does Not Bar the Commission from Issuing a Remedy Under the Public Interest Factors²⁹

INVT argued correctly that “Respondents’ FRAND arguments offer no basis for barring

²⁹ Respondents other equitable defenses are discussed in the ID, Section X at 164-176.

PUBLIC VERSION

the requested relief.” (CPBr. at 15 (citing *Certain 3G Mobile Handsets and Components Thereof*, Inv. No. 337-TA-613, Initial Determination at 43 (May 8, 2015); *Certain Audiovisual Components and Prods. Containing the Same*, Inv. No. 337-TA-837, Initial Determination at *351 (July 18, 2013)(“[i]t is a respondents’ burden to show by a preponderance of the evidence that a [F]RAND defense precludes the Commission from finding a violation of section 337.”)). INVT took its argument one step farther to argue that FRAND is irrelevant to the public interest because it is not one of factors the Commission considers as part of the public interest. (CBr. at 15; CRBr. at 29.). With that proposition, Staff essentially agrees.

Staff argued that Respondents’ argument “cannot pass legal muster” and that Respondents’ argument is “incomplete.” (SPBr. at 86; SBr. at 1, 83.). This would be so even if INVT did not meet FRAND requirements when it offered licenses to its patent portfolio to Apple, HTC and ZTE between 2015 and 2018. As Staff argued correctly, by statute the Commission is “*obligated*” to issue a remedy if it finds a violation of Section 337 unless the specific facts of an investigation would preclude a remedy. (See SPBr. at 87 n. 14 (citing *Kyocera v. International Trade Comm. ’n*, 545 F3d 1340, 1355 (Fed. Cir. 2008).)(emphasis in original).).

Staff made another compelling argument that also is recommended here. Despite glaring headings in their briefs,³⁰ nothing in the evidence that Respondents presented ties INVT’s purported FRAND violation to specific public interest factors or explains why FRAND obligations should be considered as part of the public interest considerations. (SPBr. at 1, 88 n.

³⁰ See e.g., Respondents’ Post-Hearing Brief at 55: “Allowing INVT to Seek Exclusionary Relief Without Complying FRAND is Contrary to the Public Interest;” or Respondents Post-Hearing Reply Brief at 70: “INVT’s Violation of its FRAND Obligations Precludes Entry of an Exclusion Order.

PUBLIC VERSION

15; SBr. at 1, 83-85.). In their Pre-Hearing Brief, Respondents failed even to contend that INVT's FRAND violation impacts the public interest. (See SBr. at 86 (citing RPBr. at 63-83)).

As Judge Shaw noted in the *800 Investigation*, typically, "the remedy for breaching an obligation to negotiate consists of damages; there is no specific performance available, and there is no remedy consisting of "the forced conclusion of a contract." (800 *Investigation* at 417-422.). As Judge Shaw also noted in the *800 Investigation*, French law is consistent with U.S. contract law pursuant to which an "agreement to agree" is unenforceable, but parties may enter into binding agreements to negotiate. (See *800 Investigation* ID at 422 (citing *Copeland v. Baskin Robins USA*, 96 Cal. App. 4th 1251, 1256-1259 (2002)(see also CDX-0011-13.)). The point here, is that if the Commission were to overturn the ID's finding that there is no Section 337 violation here, then INVT and Respondents would have an opportunity to negotiate a binding license.

FRAND has been raised in several investigations including but not limited to the 577, 601, 613, 669, 745 and 800. (See SBr. at 88.). As Staff observed: "not one investigation has resulted in a determination that the Commission lacks jurisdiction... to find a violation of section 337 merely because the asserted patent is allegedly subject to FRAND obligations" "or merely because a challenging party alleges a FRAND violation." (*Id.* (citing *Certain Electronic Devices Including Portable Music and Data Processing Devices, and Tablet Computers*, 2013 WL 12410037, USITC Inv. No. 337-TA-794, at *30, Comm'n Op. at * 30 (July 5, 2013)).

IV. EXCLUSIONARY ORDER, CEASE AND DESIST ORDER AND BOND

A. Legal Standard: Remedy

Pursuant to Commission Rule 210.42, an administrative law judge must issue a recommended determination on: (1) an appropriate remedy if the Commission finds a violation

PUBLIC VERSION

of Section 337; and (2) an amount, if any, of the bond to be posted. 19 C.F.R. § 210.42(a)(1)(ii). When a Section 337 violation has been found, as here, “the Commission has the authority to enter an exclusion order, a cease and desist order, or both.” *Certain Flash Memory Circuits and Prods. Containing the Same*, Inv. No. 337-TA-382, Comm’n Opinion on the Issues Under Review and on Remedy, the Public Interest and Bonding, at 26 (June 9, 1997).

Upon a finding of infringement, 19 U.S.C. § 1337(d) provides for a Limited Exclusion Order (“LEO”), directed to the accused products of named respondents, excluding any articles that infringe one or more claims of the asserted patents. 19 U.S.C. § 1337(d). A Cease and Desist Order (“CDO”) is also appropriate when the evidence demonstrates the presence of commercially significant inventory in the United States. 19 U.S.C. § 1337(f); *see also Certain Crystalline Cefadroxil Monohydrate*, Inv. No. 337-TA-293, Comm’n Opinion, USITC Pub. No. 2391, 1991 WL 790061 at *30-32 (June 1991).

Cease and desist orders are generally issued, when “with respect to the imported infringing products, respondents maintain commercially significant inventories in the United States or have significant domestic operations that could undercut the remedy provided by an exclusion order.” *Certain Magnetic Data Storage Tapes and Cartridges Containing the Same*, Inv. No. 337-TA-1012, Comm’n Op. at 129 (Apr. 2, 2018) (“*Certain Magnetic Tapes*”) (other citations omitted). A complainant seeking a cease and desist order must demonstrate, based on the record, that such a remedy “is necessary to address the violation found in the investigation so as to not undercut the relief provided in the exclusion order.” *Certain Integrated Repeaters, Switches, Transceivers, and Products Containing Same*, Inv. No. 337-TA-435, USITC Pub. No. 3547 (Oct. 2002), Comm’n Op. at 27 (Aug. 16, 2002).

Infringing articles may enter upon the payment of a bond during the sixty-day

PUBLIC VERSION

Presidential Review Period. 19 U.S.C. § 1337(j)(3). The bond is to be set at a level sufficient to “offset any competitive advantage resulting from the unfair method of competition or unfair act enjoyed by persons benefiting from the importation.” *Certain Dynamic Random Access Memories, Components Thereof and Prods. Containing Same*, Inv. No. 337- TA-242, Comm’n Opinion, 1987 WL 450856 at 37 (Sept. 21, 1987).

A Limited Exclusion Orders (“LEO”) and Cease and Desist Orders (“CDO”) Are Not Warranted Given the Findings of the ID, but Would Be Warranted if the Commission Overturns the Key Findings of the ID

1. A LEO with Carve Outs Would Be Appropriate If Respondents Provide Additional Information

INVT has not only asked that a LEO issue against each of the Respondents and their “subsidiaries, related companies, agents, and affiliates” pursuant to 19 U.S.C. § 1337(d)(1) if the Commission finds that there is a violation of Section 337, but also has argued, with Staff, that the Commission *must* issue a LEO, by statutory obligation, unless the public interest precludes a remedy. (CPBr. at 1, 11, 99 (citing 19 U.S.C. § 1337(d)(1)), 100, 146-147; SBr. at 2, 81, 87.). INVT has argued, and both Staff and the recommendation here, is that the public interest factors do not preclude the issuance of a LEO. (*Id.*; *see also* SBr. at 2, 86-87; *see* Section II., *supra*.). (*See* CPBr. at 1, 11, 100, 146-147.).

Staff did not ask for a delayed implementation or carve-out in its Pre-Hearing Brief. (*See* SPBr. at 89.). However, in its Post-Hearing Brief, Staff argued that the exclusion order should contain the “typical language allowing importers to certify that their products are not subject to exclusion in accordance with procedures that Customs and Border Protection establishes.” (SBr. at 88.). Staff also noted that if the Respondents substantiated warranty safeguards and other contractual obligations, those should be allowed. (*Id.*).

PUBLIC VERSION

Respondents argued that no exclusion order should issue because at least three (3) of the public interest factors pertaining to competition in the U.S. economy and consumers would preclude such a remedy. (RPBr. at 89; RRBr. at 79.). Alternatively, Respondents argued that if a LEO issues: “ (i) the LEO should be limited to products imported after the Presidential Review Period; (ii) entry of the LEO should be delayed for 12–24 months to provide sufficient time for Respondents to implement a potential design-around or negotiate a FRAND royalty with INVT, given that INVT claims its patents are SEPs; and (iii) the servicing, repairing, warehousing inventory, and other activities related to the Accused Products, for distribution, sale, or use in the U.S. except under license from INVT or as provided by law.” Apple provided no metrics on the value of or amount of servicing and repair it performs on its Accused Products. This is an issue for which Apple should be required to provide information if the Commission considers even a limited exclusion order.

Commission precedent provides for tailored remedies to mitigate the effects of its remedies on the public interest. *See Certain Personal Data and Mobile Communications Devices and Related Software*, Inv. No. 337-TA-710, USITC Pub. No. 4331, Comm’n Op. at 83 (June 2012) (articles subject to exclusion were delayed by four months to minimize impacts on third parties); *Certain Baseband Processor Chips and Chipsets, Transmitter and Receiver (Radio) Chips, Power Control Chips, and Products Containing Same, Including Cellular Telephone Handsets*, Inv. No. 337-TA-543, USITC Pub. No. 4258, Comm’n Op. at 151-53 (Oct 2011) (applying a grandfather provision to allow continued importation of infringing products already being imported), *rev’d on other grounds, Kyocera Wireless Corp. v. International Trade Comm’n*, 545 F.3d 1340 (Fed. Cir. 2008.).

For the most part, Respondents’ proposal is sound. Respondents explained that up to 24

PUBLIC VERSION

months would be necessary to finish negotiating a FRAND license with INVT (or its successor) and to fashion a design-around. (RBr. at 79.). Respondents presumably have a good idea of how a design around could be made given the level of engineering sophistication..³¹ Moreover, while none of the Respondents asked to be able to continue to service their current products under warranty in the United States, that, too, is recommended here.

2. Apple and HTC Have Acknowledged They Have Significant Inventory in the United States

The Commission “generally issues cease and desist orders ‘when there is a commercially significant’ amount of infringing, imported product in the United States that could be sold so as to undercut the remedy provide by an exclusion order.” *See, e.g., Certain Protective Cases and Components Thereof*, Inv. No. 337-TA-780, Comm’n Op. at 28 (Nov. 19, 2013); *see also* CBr. at 141 citing *Certain Magnetic Data Storage Tapes and Cartridges Containing the Same*, Inv. No. 337-TA-1012, Comm’n Op. at 129 (Apr. 2, 2018) (“*Certain Magnetic Tapes*”); *see also Certain Integrated Repeaters, Switches, Transceivers, and Products Containing Same*, Inv. No. 337-TA-435, USITC Pub. No. 3547 (Oct. 2002), Comm’n Op. at 27 (Aug. 16, 2002).

Respondents argued that INVT did not meet its burden to establish the entry for a CDO. (RRBr. at 79.). Respondents argued that because INVT did not offer expert testimony during the Hearing about Apple’s, HTC’s or ZTE’s inventories in the United States, it is not entitled to request a CDO. (*Id.*). Respondents’ alternative argument is largely meritless.

³¹ As noted above, in the *1065 Investigation*, in response to the Commission’s Question A, asking Apple how long it would take Apple to design around claim 1 of the ’490 patent that was found to infringe, Apple informed the Commission that it changed its software system (iOS) to remove the accused functionality. Apple’s notice of its design around was submitted within five (5) months of the issuance of the Initial Determination. If the Commission overturns the ID, and finds the Asserted Patents to be SEPs, there may not be a design-around.

PUBLIC VERSION

In INVT's Pre-Hearing Brief and again in its Post-Hearing Brief, INVT used agreed-upon Apple and HTC deposition testimony designations to argue that at least HTC and Apple have acknowledged that they maintain commercially significant inventory of the Accused Products in the United States. (CPBr. at 99-100; CBr. at 147-148.). INVT did not have to present Hearing testimony because its deposition designations on the subject were admitted into evidence by the Parties' agreement.

While INVT preserved its argument on the merits of a CDO, INVT provided some measure of precision with respect to Apple's inventory in the United States during the fourth Quarter of FY2018, it provided no information on inventory thereafter. Generally, [REDACTED]

[REDACTED]

[REDACTED] According, to Apple's representative, [REDACTED]

[REDACTED]

[REDACTED] (See CPBr. at 99-100 (citing CX-1558C Dep. (Jaynes)³² at 30:14-32:13 (inventory vs. sales), 48:12-49:21; CX-0210C (inventory) (Ex. 6 to Jaynes Dep.). [REDACTED]

[REDACTED].

[REDACTED]

[REDACTED]

[REDACTED]

³² Mr. Michael Jaynes was deposed on January 11, 2019. (Dep. (Jaynes), CX-1558C.). Mr. Jaynes served as Apple's witness who testified on the various types of and amounts of Apple Accuse Products available for sale in the United States [REDACTED]. (See CX-1558C at 17, 18.). Mr. Jaynes was a "division controller... or the lead finance person or controller for a number of different divisions in Apple." (*Id.* at 12: 1-7.).

³³ Mr. Rodrigo Calvo-Salido was deposed on January 16, 2019. (Dep. (Calvo-Salido), CX-1562C.). Mr.

[REDACTED]

[REDACTED]

[REDACTED]

[REDACTED] (See CX-1562C Tr. (Calvo-Salido) at 11:17-12:3, 11:5-15, 17:4-18:3; CX-0299C; see also Ex.3 to Dep. (Calvo-Salido), CX-0299C, Part 6 at 0223.).³⁴

If the Commission overturns the findings of the ID and decides to issue a LEO, it might request updated information for Apple and HTC inventory.³⁵

INVT noted in its Pre-Hearing Brief that in ZTE's January 10, 2019 Supplemental Response to INVT's Interrogatory No. 25, ZTE represented that it [REDACTED] [REDACTED] (CPBr. at 99 n.11, 100 n.11.).³⁶ ZTE's position did not change during or after the Hearing.

B. A Bond Is Not Supported both Because INVT's Bond Calculations Are Not Supported and INVT Has Not Proven It Would Be Damaged

If a violation of Section 337 is found, importation of the infringing articles is permitted

Calvo-Salido serves as a Supply chain planning manager for HTC America. (CX-1562 at 6:3-4.). Mr. Calvo-Salido served as HTC's witness who testified on [REDACTED] [REDACTED] (See CX-1562C at 14:1-16:2; see also Cx-0299C Parts 1-6.).

³⁴ [REDACTED]

³⁵ Staff cited to JX-022 (ZTE), JX-033 (HTC) and JX-024 (Apple) as exhibits representative of inventory to support its contention that a CDO would be appropriate. These exhibits are the Importation Stipulations between INVT and each respective Respondent that contains the identification of each Respondent's representative products that each Respondent imports in at least one unit of each. (See SBr. at 87.).

³⁶ INVT also noted in its Post-Hearing Brief that ZTE acknowledged in an earlier, December 4, 2018 Supplemental Response of to INVT's Interrogatory No. 25, that ZTE represented that it "[REDACTED]" (CBr. at 147 n. 31 (citing CX-1260C-0033.)).

PUBLIC VERSION

under bond in an amount determined by the Commission to be sufficient to protect the complainant from any injury during the Presidential review period. *See* 19 U.S.C. § 1337(j)(3).

The Commission typically sets the bond based on the differential in the sales price between the domestic industry product and the accused product or based upon a reasonable royalty rate. *See, e.g., Certain Microsphere Adhesives, Processes for Making Same, and Products Containing Same, Including Self-Stick Repositionable Notes*, Inv. No. 337-TA-366, Comm'n Op. at 24 (Jan. 1996) (setting bond based on price differentials); *Certain Plastic Encapsulated Integrated Circuits*, Inv. No. 337-TA-315, Comm'n Op. at 45 (Nov. 1992) (setting the bond based on a reasonable royalty). INVT here, or any Complainant, bears the burden of establishing the need for a bond. *Certain Rubber Antidegradants, Components Thereof, and Prods. Containing Same*, Inv. No. 337-TA-533, Comm'n Op. at 39, 40 (July 21, 2006); *see also Certain Laser Imageable Printing Plates*, Inv. No. 337-TA-636, Comm'n Op. at 9 (November 30, 2009).

INVT has requested a bond during the 60-day Presidential Review Period that equates to the royalty rates that INVT's expert, Dr. Sullivan, calculated for INVT's allegedly standard essential 3G and 4 LTE patents. (CPBr. at 100 (citing CX-1295C at ¶¶ 221-223, 229-238; CX1324C at ¶¶ 251-253, 259-275; CX-1353 ¶¶ 228-230, 236-248; CBr. at 147.). INVT suggested that the royalty rates it proposed were based upon industry royalty rate averages. (See CBr. at 147 (citing *Certain Network Devices, Related Software and Components Thereof (II)*, Inv. No. 337-TA-945, Commission Op. at 128 (June 1, 2017) ("The Commission has stated that considering industry royalty rate averages is appropriate in setting a bond.")).

INVT proposed royalty rates of [REDACTED] for each of Respondents' LTE enabled devices, and [REDACTED] for each 3G enabled device, and [REDACTED] for each device that has both capabilities.

PUBLIC VERSION

(CPBr. at 88; CBr. at 148.). INVT’s proposed per-unit prices were based on Dr. Sullivan’s analysis of what he claimed were Respondents’ existing licenses for similar standard essential patents in INVT’s entire Panasonic patent portfolio, as well as publicly available information that he obtained on programs for other 3G and 4 LTE standard technology. He testified that these would be “a reasonable guidepost for determining what would be an appropriate bond.” (Tr. (Sullivan) at 1135:4-9, 1245:24-1246:12; CBr. at 148 (referencing § II.B.3 of its Post-Hearing Brief on how the royalty rate was calculated.).

Notwithstanding INVT’s arguments and Dr. Sullivan’s testimony, there were problems with Dr. Sullivan’s royalty rate calculations based upon his analysis of a [REDACTED] [REDACTED] Dr. Sullivan’s royalty rate analysis for the Asserted Patents was flawed, in part because he changed his testimony with respect to his ability to monetize certain provisions of [REDACTED] [REDACTED] That problems with his testimony rendered his opinion suspect on a bond rate that would be commensurate or appropriate given other licenses INVT attempted, that were unsuccessful. (See Order No. 57, Omnibus Order with Respect to Respondents’ Motions to Strike [Motion Docket Nos. 1138-052, 1138-053, 1138-054 and 1138-059 (Oct. 23, 2019) and specifically the substance pertaining to Respondents’ Motion to Strike Dr. Ryan Sullivan’s Testimony, Motion Docket No. 1138-059, Order No. 57 at 10.).³⁷ [REDACTED]

³⁷ Dr. Sullivan’s testimony on his analysis of the Samsung license in the context of his FRAND analysis was found to be problematic because he changed his testimony which undermined his initial analysis. That does not mean his testimony was necessarily discredited throughout, as this recommended decision reflects. Similarly, merely because I found some of Dr. Eisenach’s testimony to be unsupported does not mean that was the case throughout. Moreover, the history of the licensing negotiations between Inventegy/INVT and Respondents is not discussed at any length in this document, in part and instead focused briefly on the problems with INVT’s bond rate proposal and the ultimate finding that INVT is not similarly situated with Respondents since it does not invest in products or innovation.

[REDACTED]

[REDACTED]

Respondents argued that while no bond is required, if the Commission does determine to enter a bond, it should be set at zero, because INVT “did not assert, let alone establish, that a bond is necessary to “offset any competitive advantage resulting from a violation.” (RPBr. at 90; RRBr. at 80 (*Citing Certain Coenzyme Q10 Prods. & Methods of Making Same*, Inv. No. 337-TA-790, Initial Determination., 2012 WL 5383646, at *175-177 (Sept. 27, 2012.) (recommending zero bond). As Dr. Stephen Prowse³⁸ one of Respondents’ experts noted, Dr. Sullivan did not explain how INVT would be disadvantaged competitively or how it would be injured, *per se*, because [REDACTED] (See Tr. (Prowse) at 2345:9-24; *accord* SBr. at 89-90).). That is a strong, supported argument.

If the Commission were to overturn the findings in the ID and find that the Asserted Patents were SEPs, part of the recommended delay in implementation would give INVT (or now its successor-in-interest) to negotiate a license on FRAND terms. Arguably, a license would make INVT whole since it [REDACTED]

[REDACTED]

³⁸ When he testified during the Hearing, Dr. Stephen Prowse was a Senior Managing Director at FTI Consulting based in Dallas. (Ex. 8 to RPSt.). Dr. Prowse provides “economic, financial statistical and valuation analysis to clients involved in litigation, arbitration, mediation... where parties are engaged in complex business disputes.” (*Id.*). At other points in his career, Dr. Prowse was a partner in KPMG’s Forensic Services practice and as a senior economist and policy advisor in the Federal Reserve System. Dr. Prowse holds a B.A. and M.A. in Economics from Pembroke College, Cambridge, a Ph.D. in economics from University of California Los Angeles, and an MSc. in economics from California Institute of Technology. (*Id.*). Dr. Prowse testified for Respondents on domestic industry with and their implications for remedy.

PUBLIC VERSION

Respondents also argued that if there is a choice for a bond, it should not be taken from

[REDACTED]

[REDACTED]

[REDACTED] (See

RPBr. at 90 (citing Dep. (Sullivan) at 327:18-21; Prowse Reb. Rpt. at ¶ 142.).⁴⁰

Alternatively, Respondents argued that if any bond rate is to be recommended or based about royalty rates, the royalty rate that should apply should be based on [REDACTED]

[REDACTED] (RPBr. at 91; RBr. at 59-62; RRB. at 80.). Respondents argued that they were [REDACTED]

[REDACTED] (RBr. at 59, 60.) They noted that while Dr. Sullivan agreed that

Respondents were similarly situated with Respondents, [REDACTED]

[REDACTED]

[REDACTED] (RBr. at 60 (citations omitted).)

³⁹ INVT obtained the Asserted Patents from Inventergy, Inc. (“Inventergy”), a company that is in the business of licensing patent portfolio. (See RPBr. at 2 (citing JX-0013; JX-0009C (INVT has no employees). RX-2387C, Dep. (Moreland) 145:7–8.). Inventergy obtained the Asserted Patents from Panasonic Corporation (“Panasonic”) as part of a much larger patent portfolio. (See CPBr. at 8.). Inventergy later assigned the Asserted Patents to INVT. (*Id.* (citing JX-0009, JX-0010C; JX-0013C.)). According to INVT, as of April 27, 2017, INVT held all right, title and interest in and to the Asserted Patents. (CPBr. at 8.). INVT also argued that once it took ownership of the Asserted Patents, it stepped “into the shoes of Inventergy.” (CPBr. at 11 (citing *Barnes & Noble, Inc. v. LSI Corp.*, 849 F.Supp. 2d 925, 933 (N.D. Cal. 2012)(a predecessor patent holder’s conduct could be imputed to its successors/assignees with respect to affirmative defenses.)). The ID contains a finding that INVT has rights to the Asserted Patents and that INVT has standing to sue in the USITC.

⁴⁰ Respondents cited to *Certain Marine Sonar Imaging Devices, Including Downscan & Sidescan Devices, Prods. Containing the Same, & Components Thereof*, Inv. No. 337-TA-921, Comm’n Op., 2016 WL 10987364 at *56-57 (Jan. 6, 2016), as part of its proposition that neither INVT nor Respondents had agreed to a royalty rate based upon an agreed-upon license. (RPBr. at 90.).

PUBLIC VERSION

[REDACTED]

[REDACTED]

[REDACTED]

[REDACTED]

[REDACTED]

[REDACTED]

[REDACTED]

[REDACTED] (See JX-0016C; Tr. (Meyer) at 2110:6-2111:14; see also RX-1555C.).⁴¹

[REDACTED]

[REDACTED]

[REDACTED]

[REDACTED]

[REDACTED] (See RBR. at 62 (citing RX-1791C)). [REDACTED]

[REDACTED]

[REDACTED] (See RBr. at 60 n.13 (citations omitted)). [REDACTED]

[REDACTED]

[REDACTED] (RBr.at 59-61.).

In fact, and by contrast, the royalty rate that INVT offered to Respondents of [REDACTED] per unit (and is trying to use for a bond rate) is [REDACTED] that the royalty rate INVT agreed to with [REDACTED]

⁴¹ When he testified during the Hearing, Mr. Paul K. Meyer was President and Co-Founder of TM Financial Forensics, LLC. (Ex. 7 to RPSt.). Mr. Myer is a Certified Public Accountant and Certified Fraud Examiner. (*Id.*). He also is Accredited in Business Valuation (CPA-ABV.). (*Id.*). Mr. Meyer testified on behalf of Respondents as an “expert in IP valuation and evaluating FRAND royalties” who testified on the Public Interest, including INVT’s failure to meet its FRAND obligations before it sought injunctive relief. (RPSt.).

PUBLIC VERSION

[REDACTED]. (See RBr. at 60.). As Respondents noted, for only a [REDACTED], INVT seeks some [REDACTED] from Respondents. (RBr. at 59-70 (citations omitted).).

Respondents argued, with persuasive supporting evidence from its experts and analyses of INVT's licensing offer, that the royalty rate that INVT is suggesting as a license (and as the basis for its bond) is discriminatory ⁴²under *TCL Commc'n Tech. Holdings Ltd. v. Telefonaktiebolaget LM. Ericsson*, 2018 WL 4488286, at *5 (C.D. Cal. Sept. 14, 2018) (“TCL”).

While Staff did not consider whether INVT's bond proposal rates were FRAND, or even reasonable, Staff agreed with Respondents' primary argument that INVT did not meet its burden of even showing it is entitled to a bond rate commensurate with the proposed (and alleged) FRAND offer Inventergy (and later INVT) made to Respondents. (SBr. at 89-90 (citing *Certain Coenzyme QJO Prods. And Methods of Making Same*, Inv. No. 337-TA-790, Initial Determination (Sept. 27, 2012 (recommended that Commission no bond because complainant failed to demonstrate the appropriate bond amount); *Certain Mobile Tels. and Wireless Commc'n Devices Featuring Dig. Cameras, and Components Thereof*, Inv. No. 337-TA-703, Recommended Determination (Jan. 24, 2011)(recommending no bond because complainant did not meet its burden in providing evidence on the necessity of a bond)).). Staff did not make an alternative argument with respect to the bond rate that INVT suggested or Respondents' argument that the proposed INVT rate would be discriminatory.

In this case, this recommendation adopts Staff's and Respondents' primary argument that

⁴² Respondents noted that TCL holds that non-discrimination in a FRAND offer requires that “like, or close to, like rates must be offered to firms that are similarly situated.” (RBr. at 59 (citing *TCL, 2018 WL 4488286*, at *31).).

PUBLIC VERSION

a zero bond is warranted. INVT has not shown that the bond it proposed is reflective of any injury INVT may have incurred or will occur. (See SBr. at 90 (citing Tr. (Prowse) at 2345:9-21); RBr. at 80.). [REDACTED] so, if that basis were to be considered, [REDACTED] (Tr. (Prowse) at 2345:9-24.).

If a royalty rate is considered, while INVT argued for its own [REDACTED] proposed royalty rates to the Respondents, not one of the Respondents, i.e. neither Apple, nor HTC nor ZTE agreed to INVT's proposed rates. The only comparative royalty rate is that which INVT negotiated with [REDACTED] (See RRB. at 81 (citing *Certain Mobile Telephone Headsets, Wireless Communication Devices, and Components Thereof*, Inv. No. 337-TA-578, Initial Determination at 259 (Dec. 12, 2007) (“the Commission may also rely on royalty rates established on the basis of license agreement or other reliable evidence of an appropriate royalty rate for the patents at issue.”)).

Nonetheless, even the [REDACTED] is rejected here.⁴³ Based upon a review of the totality of evidence (and without going into a detailed analysis of the [REDACTED] INVT Respondents used) INVT had the opportunity to negotiate with Respondents using the [REDACTED], but chose not to. Given the totality of evidence, INVT did not support its proposed royalty rate.

⁴³ Starting in January 2015, and consistently throughout its negotiations with INVT and throughout this Investigation, Apple rejected INVT's proposed royalty rate for the patent portfolio that it offered Apple that included the Asserted Patents on grounds, inter alia, that the Asserted Patents: (a) were not SEPs; (b) that INVT had failed to offer claim chart comparisons, and (c) the royalty rates INVT offered were discriminatory and did not comport with Apple's valuation of the patent portfolio INVT offered.

PUBLIC VERSION

For the reasons explained, it is the recommendation here that no bond enter even if the Commission overturns the findings of the ID that there is no infringement of the Asserted Patents, the Asserted Patents are SEPs, and there is no violation of Section 337.

V. CERTIFICATION TO THE COMMISSION

This Recommendation on the Public Interest and on Remedy and Bond is certified to the Commission. All orders and documents, filed with the Secretary, including the exhibit lists enumerating the exhibits received into evidence in this Investigation, that are part of the record, as defined in 19 C.F.R. § 210.38(a), are not certified, since they are already in the Commission's possession in accordance with Commission Rules. *See* 19 C.F.R. § 210.38(a). In accordance with 19 C.F.R. § 210.39(c), all material found to be confidential under 19 C.F.R. § 210.5 is to be given *in camera* treatment.

After the Parties have provided proposed redactions of confidential business information (“CBI”) that have been evaluated and accepted, the Secretary shall serve a public version of this ID upon all parties of record. The Secretary shall serve a confidential version upon counsel who are signatories to the Protective Order (Order No. 1) issued in this Investigation.

Pursuant to 19 C.F.R. § 210.42(h), this Initial Determination shall become the determination of the Commission unless a party files a petition for review pursuant to 19 C.F.R. § 210.43(a) or the Commission, pursuant to 19 C.F.R. § 210.44, orders on its own motion a review of the Initial Determination or certain issues therein.

Within fourteen (14) days of the date of this document, the Parties shall submit to the Office of Administrative Law Judges a joint statement whether or not they seek to have any portion of this document deleted from the public version. The Parties' submission shall be made by hard copy and must include a copy of this ID with yellow highlighting, with or without red

PUBLIC VERSION

brackets, indicating any portion asserted to contain CBI to be deleted from the public version. The Parties' submission shall also include a chart that: (i) contains the page number of each proposed redaction; and (ii) states (next to each page number) every sentence or phrase, listed separately, that the party proposes be redacted; and (iii) for each such sentence or phrase that the party proposes be redacted, a citation to case law with an explanation as to why each proposed redaction constitutes CBI consistent with case law. Any proposed redaction that is not explained may not be redacted after a review. The Parties' submission concerning the public version of this document need not be filed with the Commission Secretary.

SO ORDERED.

MaryJoan McNamara
Administrative Law Judge

PUBLIC CERTIFICATE OF SERVICE

I, Lisa R. Barton, hereby certify that the attached **RECOMMENDED DETERMINATION** has been served via EDIS upon the Commission Investigative Attorney, **Reginald Lucas, Esq.**, and to the following parties as indicated, on **April 16, 2020**.



Lisa R. Barton, Secretary
U.S. International Trade Commission
500 E Street, SW, Room 112
Washington, DC 20436

On Behalf of Complainant INVT SPE LLC:

Bryan J. Vogel, Esq.
ROBIN KAPLAN LLP
399 Park Avenue, Suite 3600
New York, NY 10022
Email: bvogel@robinskaplan.com

- Via Hand Delivery
- Via Express Delivery
- Via First Class Mail
- Other: Email Notification of Availability for Download

On Behalf of Respondent Apple Inc.:

Robert A. Appleby, P.C.
KIRKLAND & ELLIS LLP
601 Lexington Avenue
New York, New York 10022
Email: Robert.appleby@kirkland.com

- Via Hand Delivery
- Via Express Delivery
- Via First Class Mail
- Other: Email Notification of Availability for Download

On Behalf of Respondents HTC Corporation and HTC America, Inc.:

Stephen S. Korniczky, Esq.
SHEPPARD, MULLIN, RICHTER & HAMPTON LLP
12275 El Camino Real, Suite 200
San Diego, California 92130
Email: skorniczky@sheppardmullin.com

- Via Hand Delivery
- Via Express Delivery
- Via First Class Mail
- Other: Email Notification of Availability for Download

**CERTAIN LTE- AND 3G-COMPLIANT CELLULAR
COMMUNICATIONS DEVICES**

Inv. No. 337-TA-1138

Certificate of Service – Page 2

**On Behalf of Respondents ZTE Corporation and ZTE (USA)
Inc.:**

Jay H. Reiziss, Esq.

MCDERMOTT WILL & EMERY LLP

500 North Capitol Street, NW

Washington, DC 20001

Email: jreiziss@mwe.com

- Via Hand Delivery
- Via Express Delivery
- Via First Class Mail
- Other: Email Notification
of Availability for Download

Public Version

UNITED STATES INTERNATIONAL TRADE COMMISSION

Washington, D.C.

In the Matter of

**CERTAIN LTE- AND 3G-COMPLIANT
CELLULAR COMMUNICATIONS
DEVICES**

Inv. No. 337-TA-1138

INITIAL DETERMINATION ON VIOLATION OF SECTION 337

Administrative Law Judge MaryJoan McNamara

(February 18, 2020)

Appearances:

For the Complainant INVT SPE LLC:

Bryan J. Vogel, Esq. and Derrick J. Carman, Esq. of Robins Kaplan LLP, New York, NY.

Christopher A. Seidl, Esq. and John K. Harting, Esq. of Robins Kaplan LLP, Minneapolis, MN.

Li Zhu, Esq. of Robins Kaplan LLP, Mountain View, CA.

For the Respondent Apple Inc:

Paul F. Brinkman, P.C. of Kirkland & Ellis LLP, Washington, DC.

Greg S. Arovas, P.C.; Robert A. Appleby, P.C.; Jeanne M. Heffernan, P.C.; Leslie M. Schmidt, Esq.; Alan Rabinowitz, Esq. of Kirkland & Ellis LLP, New York, NY.

Akshay S. Deoras, Esq. of Kirkland & Ellis LLP, San Francisco, CA.

David Rokach, Esq. of Kirkland & Ellis LLP, Chicago, IL.

Hannah Cannom, Esq. of Walker Stevens Cannom LLP, Los Angeles, CA.

For the Respondents HTC Corporation and HTC America, Inc.:

Stephen S. Korniczky, Esq.; Martin R. Bader, Esq.; Ericka J. Schulz, Esq.; Nam Kim, Esq.; Ryan P. Cunningham, Esq.; Eric K. Gill, Esq.; Ximena Solano Suarez, Esq.; Michael J.

Public Version

Hopkins, Esq.; Emilio A. Cazares, Esq. of Sheppard, Mullin, Richter & Hampton LLP, San Diego, CA.

Edward V. Anderson, Esq. of Sheppard, Mullin, Richter & Hampton LLP, Pala Alto, CA.

For the Respondents ZTE Corporation and ZTE (USA) Inc:

Jay H. Reiziss, Esq. and Alexander P. Ott, Esq. of McDermott Will & Emery LLP, Washington, DC.

Jiaxiao Zhang, Esq. of McDermott Will & Emery LLP, Washington, DC.

Charles M. McMahon, Esq.; Brian A. Jones, Esq.; and Thomas M. DaMario, Esq. of McDermott Will & Emery LLP, Chicago, IL.

For the Commission Investigative Staff:

Margaret D. Macdonald, Esq., Director; Anne Goalwin, Esq., Supervisory Attorney; and Reginald Lucas, Esq., Investigative Attorney, of the Office of Unfair Import Investigations, U.S. International Trade Commission, Washington, DC.

SELECTED SUMMARY FINDINGS

Pursuant to the Notice of Investigation, 83 Fed. Reg. 53105, dated October 19, 2018, this is the Initial Determination (“ID”) of the Investigation in the Matter of Certain LTE- and 3G-Compliant Cellular Communications Devices, United States International Trade Commission (“USITC”) Investigation No. 337-TA-1138. *See* 19 C.F.R. § 210.42(a).

I have found that Complainant INVT SPE LLC (“INVT” or “Complainant”) has not proven by a preponderance of the evidence that any of Respondents Apple Inc. (“Apple”), HTC Corporation and HTC America, Inc. (collectively, “HTC”), ZTE Corporation and ZTE (USA) Inc. (collectively, “ZTE,” and together with Apple and HTC, “Respondents,” and Respondents together with INVT, the “Private Parties”) has violated subsection (b) of Section 337 of the Tariff Act of 1930 (“Section 337”), in the importation into the United States, the sale for importation, or the sale within the United States after importation of certain LTE-and 3G-compliant cellular communications devices. 19 U.S.C. § 1337, as amended.

I have found that none of the Asserted Patents is essential to the 3G or LTE standard.

I have found that INVT has failed to prove by a preponderance of the evidence that any Accused Product¹ satisfies an asserted patent claim that remains in this Investigation: claim 4 of U.S. Patent No. 7,206,587 (“the ’587 patent”); claims 3 and 4 of U.S. Patent No. 6,760,590 (“the ’590 patent”); and claims 1 and 2 of U.S. Patent No. 7,343,439.

I have found that Respondents have failed to prove by clear and convincing evidence that

¹ The Accused Products comprise certain personal electronic devices, such as smartphones, smart watches and tablets, that are compliant with the LTE and/or 3G 3GPP specifications, and which enable LTE and/or 3G data transfer and communications. (Notice of Institution of Investigation at 2 (Doc. ID No. 658973 (Oct. 19, 2018))). The Parties stipulated to the use of Representative Products. (*See* Representative Product Stipulation at 1-2 (Doc. ID No. 688512 (Sept. 18, 2019)) (identifying both “representative” and “represented” Accused Products for each Respondent)).

Public Version

any of the Asserted Claims are invalid.

I have found that INVT has failed to prove by a preponderance of the evidence that any of its domestic industry products (“DI Products”) have satisfied the technical industry prong of the domestic industry requirement.

I have found that, if INVT had satisfied the technical industry prong of the domestic industry requirement, INVT would have satisfied the economic prong of the domestic industry requirement under Sections 337(a)(3)(A) and 337(a)(3)(B).

A complete recommendation on remedy and bond will be forthcoming together with an analysis of the effects of the public interest factors on the issue of remedy, albeit in the alternative, pursuant to 19 C.F.R. § 210.42(a)(1)(ii)(A), (B) and (C).

Because I have not found a violation of Section 337, I will not be recommending that an exclusion order or a cease and desist order issue. A bond is not warranted based upon the findings in this initial decision.

However, Respondents jointly made an argument that tied to the public interest the issue of the “Fair, Reasonable and Non-Discriminatory” or “FRAND” negotiations by which INVT attempted to license the Asserted Patents to Respondents. Therefore, although addressed briefly in this document, FRAND will be addressed more thoroughly in a document that will be filed consistent with 19 C.F.R. § 210.42(a)(1)(ii)(A), (B) and (C).

TABLE OF CONTENTS

I.	SUMMARY OVERVIEW AND FINDINGS	1
	A. Overview.....	1
	B. Summary Findings.....	2
II.	BACKGROUND	3
	A. Institution and Selected Procedural History	3
	B. The Parties	11
	1. Complainant INVT SPE LLC.....	11
	2. Respondent Apple.....	12
	3. HTC Respondents	12
	4. ZTE Respondents.....	13
III.	JURISDICTION, IMPORTATION, AND STANDING	13
	A. The Commission Has Jurisdiction	13
	1. The Commission Has Subject Matter Jurisdiction.....	14
	2. The Commission Has Personal Jurisdiction	14
	3. The Commission Has <i>In Rem</i> Jurisdiction.....	14
	B. INVT Has Standing in the Commission	15
IV.	THE ASSERTED PATENTS.....	22
	A. Overview of the '587 and '590 Patents.....	22
	B. Overview of '439 Patent	25
V.	THE PRODUCTS AT ISSUE	30
	A. Apple's Accused Products	31
	B. HTC's Accused Products	32
	C. ZTE's Accused Products.....	33
	D. INVT's Domestic Industry Products	35
VI.	PERSON OF ORDINARY SKILL IN THE ART	37
VII.	U.S. PATENT NOS. 7,206,587 & 6,760,590.....	38
	A. INVT Failed to Prove That Claim 4 of the '587 Patent and Claims 3 and 4 of the '590 Patent Are Essential to the 3G and LTE Standards	38
	1. Legal Standard of "Essentiality" for Standard Essential Patents.....	38
	1. Essentiality Analysis.....	39

Public Version

B.	INVT Failed to Prove That the Accused Products Satisfy Claims 3 and 4 of the '590 patent and Claim 4 of the '587 Patent	53
1.	Infringement Overview	53
2.	Infringement Legal Standard	55
3.	INVT Failed to Prove That the “Encodes the Information” Limitations of Claims 3 and 4 of the '590 Patent and Claim 4 of the '587 Patent Are Satisfied by the Accused Products	56
4.	INVT Has Proven Only That Certain Limitations of Claims 3 and 4 of the '590 Patent and Claim 4 of the '587 Patent Are Satisfied by the Accused Products and Are Essential to the 3G and LTE Standards.....	65
a)	Preamble. '590 patent, cl. 3[pre]: A communication terminal apparatus comprising / '587 patent, cl. 4[pre]: A communication terminal apparatus comprising	65
b)	Measurer. '590 patent, cl. 3[a]: a measurer that measures a downlink channel quality and outputs information that is generated in association with said downlink channel quality and composed of a plurality of digits including an upper digit and a lower digit / '590 patent, cl. 4: The communication terminal apparatus according to claim 3, wherein the upper digit contains a most significant bit of the information / '587 patent, cl. 4[a]: a measuring device that measures reception quality of a pilot signal to output information having a plurality of bits that indicate the measured reception quality	66
a)	Transmitter. '590 patent, cl. 3[c]: a transmitter that transmits the encoded information to a base station apparatus / '587 patent, cl. 4[c]: a transmitter that transmits the code word	73
C.	INVT Failed to Prove Technical Domestic Industry for the '587/'590 Patents ...	74
1.	Technical Domestic Industry Legal Standard.....	74
2.	Technical Domestic Industry Analysis	75
D.	Respondents Failed to Prove Invalidity of the Asserted Claims.....	76
1.	Obviousness Overview	77
2.	Obviousness Legal Standard.....	77
3.	Prior Art Background: Padovani and AAPA	79
4.	The Asserted Claims Are Not Obvious Over Padovani and Seshadri	86
5.	The Asserted Claims Are Not Obvious Over Padovani and Jarvinen	90
6.	The Asserted Claims Are Not Obvious Over Padovani and Marshall.....	93

Public Version

7.	INVT Failed to Prove a Secondary Consideration of Non-Obviousness .	96
8.	Respondents’ Argument That the Combination of AAPA and TS 25.212 V3.2.0 Render the Asserted Claims Obvious Is Not Supported...	99
9.	Respondents’ Written Description Argument Is Unavailing	101
VIII.	U.S. PATENT NO. 7,848,439	103
A.	INVT Failed to Prove That Independent Claim 1 of the ’439 Patent Is Essential to the LTE Standard	103
B.	Infringement.....	111
1.	Infringement Overview	111
2.	INVT Failed to Prove That the Accused Products Practice Independent Claim 1 and Dependent Claim 2 of the ’439 Patent	112
a)	Independent Claim 1	112
i.	[1Pre]: “A communication apparatus comprising”	112
ii.	[1a]: “a channel estimating section that carries out a channel estimation per subband”	112
iii.	[1b]: “a parameter deciding section that decides modulation parameters and coding parameters per subband group comprised of a plurality of the subbands, based on a result of the channel estimation per subband”	117
iv.	[1c]: “a parameter information transmission section that transmits, to a communicating party, parameter information indicating the modulation parameters and the coding parameters decided at the parameter deciding section”	119
v.	[1d] and [1e]: [1d] “a receiving section that receives a signal containing data modulated and encoded <u>on a per subband group basis</u> at the communicating party using the modulation parameters and the coding parameters of the parameter information transmitted at the parameter information transmission section;” [1e] “a data obtaining section that demodulates and decodes the received signal received at the receiving section <u>on a per subband group basis</u> . . .”	121
vi.	[1e]: “a data obtaining section that demodulates and decodes the received signal received at the receiving section on a per subband group basis using the <u>modulation parameters and the coding parameters decided at the parameter deciding section, and</u>	

Public Version

obtains the data contained in the received signal” 126

vii. [1f]: “a pattern storage section that stores in advance patterns for selecting subbands constituting the subband groups wherein the parameter deciding section decides the modulation parameters and the coding parameters per subband group comprised of the subbands selected based on the patterns stored in the pattern storage section” 128

b) Dependent Claim 2 129

i. “The communication apparatus of claim 1, wherein the parameter deciding section decides the modulation parameters and the coding parameters per subband group constituted from a pattern, among the patterns, for selecting a plurality of the subbands neighboring on a frequency axis.” 129

C. Technical Prong of Domestic Industry 129

1. Technical DI Overview 129

2. INVT Failed to Prove That the 439 DI Products Practice Independent Claim 1 and Dependent Claim 2 of the ’439 Patent 130

a) Independent Claim 1 130

ii. [1Pre]: “A communication apparatus comprising” 130

iii. [1a]: “a channel estimating section that carries out a channel estimation per subband” 130

iv. [1b]: “a parameter deciding section that decides modulation parameters and coding parameters per subband group comprised of a plurality of the subbands, based on a result of the channel estimation per subband” 131

v. [1c]: “a parameter information transmission section that transmits, to a communicating party, parameter information indicating the modulation parameters and the coding parameters decided at the parameter deciding section” 132

vi. [1d] and [1e]: [1d] “a receiving section that receives a signal containing data modulated and encoded on a per subband group basis at the communicating party using the modulation parameters and the coding parameters of the parameter information transmitted at the parameter information transmission section;” [1e] “a data obtaining section that demodulates and

	decodes the received signal received at the receiving section on a per subband group basis using the modulation parameters and the coding parameters decided at the parameter deciding section, and obtains the data contained in the received signal”	133
vii.	[1f]: a pattern storage section that stores in advance patterns for selecting subbands constituting the subband groups wherein the parameter deciding section decides the modulation parameters and the coding parameters per subband group comprised of the subbands selected based on the patterns stored in the pattern storage section.....	134
D.	Invalidity	135
1.	Invalidity Overview	135
2.	Respondents Failed to Prove That the Combination of Li (RX-1615), Vijayan (RX-1616), and Hashem (RX-1617) Render Obvious Independent Claim 1 and Dependent Claim 2 of the ’439 Patent.....	136
3.	INVT Failed to Prove Secondary Considerations of Non-Obviousness.	141
IX.	DOMESTIC INDUSTRY REQUIREMENT: ECONOMIC PRONG	141
A.	Legal Standard	141
B.	Economic Prong Overview	144
C.	The Samsung DI Products Are the Proper Relevant “Article”	145
D.	Complainant Has Satisfied the Economic Prong of the Domestic Industry Requirement Under Subsections 337(a)(3)(A) and (B).....	149
1.	Complainant’s Investments in Plant and Equipment Are Significant	149
2.	Complainant’s Investments in Employment of Labor and Capital Are Significant.....	158
E.	Complainant Has Not Satisfied the Economic Prong of the Domestic Industry Requirement Under Subsection 337(a)(3)(C).....	163
X.	RESPONDENTS’ AFFIRMATIVE DEFENSES	164
A.	Overview.....	164
B.	Respondents’ Patent Exhaustion Affirmative Defense Is Not Supported	166
C.	Respondents’ Affirmative Defense of Unclean Hands Defense Is Not Applicable.....	172
D.	Apple’s Estoppel and Waiver Defenses Are Unavailing.....	176
XI.	FINDINGS OF FACT AND CONCLUSIONS OF LAW	179

XII. CONCLUSION AND ORDER 180

ABBREVIATIONS

The following shorthand references to the parties, related U.S. agencies, and related proceedings are used in this Initial Determination:

Complainant or INVT	Complainant INVT SPE LLC
Apple	Respondent Apple Inc.
HTC	Respondents HTC Corporation and HTC America, Inc., collectively
ZTE	Respondents ZTE Corporation and ZTE (USA) Inc., collectively
Respondents	Apple, HTC, and ZTE, collectively
Staff	Office of Unfair Import Investigations
CBP	U.S. Customs and Border Protection
USPTO or PTO	U.S. Patent and Trademark Office
PTAB	Patent Trial and Appeal Board

The following abbreviations for pleadings, exhibits, briefs, transcripts, and Orders are used in this Initial Determination:

Compl.	Complaint
Apple Resp.	Response of Apple to the Notice of Investigation and Complaint Under Section 337 of the Tariff Act of 1930, as Amended
HTC Resp.	Response of HTC to the Notice of Investigation and Complaint Under Section 337 of the Tariff Act of 1930, as Amended
ZTE Resp.	Response of ZTE to the Notice of Investigation and Complaint Under Section 337 of the Tariff Act of 1930, as Amended
CX	Complainant's exhibit
CDX	Complainant's demonstrative exhibit

Public Version

CPX	Complainant’s physical exhibit
CPBr.	Complainant’s Pre-Hearing Brief
CBr.	Complainant’s Initial Post-Hearing Brief
CRBr.	Complainant’s Post-Hearing Reply Brief
CPSt.	Complainant’s Pre-Hearing Statement
JX	Joint exhibit
RX	Respondents’ exhibit
RDX	Respondents’ demonstrative exhibit
RPX	Respondents’ physical exhibit
RPBr.	Respondents’ Pre-Hearing Brief (by all Respondents jointly)
RBr.	Respondents’ Initial Post-Hearing Brief (by all Respondents jointly)
RRBr.	Respondents’ Post-Hearing Reply Brief (by all Respondents jointly)
RPSt.	Respondents’ Pre-Hearing Statement (by all Respondents jointly)
SPBr.	Staff’s Pre-Hearing Brief
SBr.	Staff’s Initial Post-Hearing Brief
SRBr.	Staff’s Post-Hearing Reply Brief
SPSt.	Staff’s Pre-Hearing Statement
Tr.	Evidentiary hearing transcript
Dep. Tr.	Deposition transcript
Markman Order	Order No. 40 (July 15, 2019)
Order Clarifying CC	Order No. 52 (Sept. 13, 2019) Clarifying Claim Construction Underpinning for Denial of Respondents’ Motion for Summary Determination of Non-Infringement and No Technical Domestic Industry

Public Version

COMBr.	Complainant’s Opening <i>Markman</i> Brief
ROMBr.	Respondents’ Opening <i>Markman</i> Brief
SOMBr.	Staff’s Opening <i>Markman</i> Brief
CRMBr.	Complainant’s Reply <i>Markman</i> Brief
RRMBr.	Respondents’ Reply <i>Markman</i> Brief
SRMBr.	Staff’s Reply <i>Markman</i> Brief
Joint CC Chart	Joint Claim Construction Chart (Doc. ID No. 665066 (Dec. 21, 2018))

The following shorthand references to certain products and patents at issue are used in this Initial Determination:

'587 patent	U.S. Patent No. 7,206,587
'590 patent	U.S. Patent No. 6,760,590
Related Patents	'587 patent and '590 patent (the '587 patent is a continuation of application No. 10/089,605, filed on Apr. 1, 2002, now U.S. Patent No. 6,760,590)
'439 patent	U.S. Patent No. 7,848,439
Asserted Patents	'587 patent, '590 patent, and '439 patent, collectively
Apple Accused Products	iPhone 8 A1863, which is representative of: iPad Mini 4 A1550; iPad Pro 10.5 A1709; iPhone 7 A1660; iPhone 7 Plus A1661; iPhone 8 A1863; iPhone 8 Plus A1864; iPhone X A1865; Apple Watch Series 3 A1860; Apple Watch Series 3 A1861; and iPad 9.7” 6th Generation A1954. (Representative Product Stipulation at 1-2 (Doc. ID No. 688512 (Sept. 18, 2019)).). iPhone XS A1920, which is representative of: iPhone 7 A1778; iPhone 7 Plus A1784; iPhone 8 A1905; iPhone 8 Plus A1897; iPhone X A1901; iPhone XR A1984; iPhone XS Max A1921; iPad Pro 11” A2013; iPad Pro 12.9” A2014; iPad Air (2019) A2123; iPad Mini (2019) A2124; Apple Watch Series 4 A1975; and Apple Watch Series 4 A1976. (Representative Product Stipulation at 1-2.).

Public Version

HTC Accused Products

HTC U11, which is representative of: U11 Life; U12+; Exodus 1; and HTC 5G Hub RTX. (Representative Product Stipulation at 2.).

ZTE Accused Products

ZTE Max XL, which is representative of: Boost Max (N9520); Sonata 4G (Z740G/Z740); Grand Memo 2(Z980L); Concord II (Z730); Altair (Z431); Grand S Pro (N9835); Compel (Z830); Zmax (Z970); Grand X Max (Z787); Prelude 2 (Z669); Zinger (Z667T); Altair 2 (Z434); Lever (Z936L); Speed (N9130); Grand X Max+ (Z987); Imperial II (N9101); Paragon (Z753G); Overture 2 (Z813); Sonata 2 (Z755); Maven (Z812); Boost Max+ (N9521); Warp Elite (N9518); Max Duo LTE (Z962BL); Obsidian (Z820); Prestige (N9132); Avid Plus (Z828); Imperial Max (Z963U); Grand X Max 2 (Z988); Axon 7 (A2017U); Midnight Pro (Z828TL); Sonata 3 (Z832); Zmax Grand (Z916BL); Zmax Pro (Z981); Zmax Champ (Z917VL); Zfive L LTE (Z861BL); Warp 7 (N9519); Grand X 4 (Z956); Cymbal-T LTE (Z233V); Fanfare 2 (Z815); Cymbal (Z320); Axon 7 Mini (B2017G/A7S); Cymbal LTE (Z233V); Avid Trio (Z833); Majesty Pro (Z798BL); Blade V8 Pro (Z978); Prestige 2 (N9136); Blade Max 3 (Z986U); Avid 916 (Z916); Jasper (Z718TL); Blade Spark (Z971); and Blade X Max (Z983); Cymbal-G LTE (Z232TL); ZFive 2 LTE (Z837VL); Maven 2 (Z831); Maven 3 (Z835); Blade Z Max (Z982); Max Blue (Z986DL); Blade Vantage (Z839); Tempo X (N9137); Tempo Go (N9137); Avid 828 (Z828); Axon M (Z999); Blade Max 2S (Z6410S); Blade Max View (Z610DL); Quartz Smart Watch (ZW10); Aspect (F555); Avid 4 (Z855); Axon (A1R); Axon 7 Mini.(A7S); Axon Pro (A1P); Blade Force (N9517); Blade X (Z965); Boost Force (N9100); Boost Warp 4G (N9521); Citrine (Z717BL); Cymbal-T (Z353VL); Fanfare 3 (Z852); Grand X 3 (Z959); Majesty Pro (Z799VL); Majesty Pro Plus (Z899VL); Max Duo LTE (Z963BL/Z963VL); Overture 3 (Z851M); Primetime (K92); Stratos (Z819L); Trek 2 HD (K88); ZFive G (Z557BL); ZFive L (Z861BL); ZFive L LTE (Z862VL); and Zmax 2 (Z955). (Representative Product Stipulation at 2-3.).

Accused Products

Apple Accused Products, HTC Accused Products, and ZTE Accused Products, collectively

DI Products

Samsung Galaxy S9, which is representative of: Galaxy S8 SM-G950U; Galaxy S8 SM-G950X; Galaxy S8 Active SM-G892A; Galaxy S8 Active SM-G892U; Galaxy S8 Plus SM-G955U; Galaxy S8 Plus SM-G955X; Galaxy Note8 SM-N950U; Galaxy Note8 SMN950X; Galaxy S9 SM-G960X; Galaxy S9 Plus SM-G965U; Galaxy S9 Plus SM-G965X; Galaxy Note9 SM-N960U; and Galaxy Note9 SM-N960X. (Representative Product Stipulation at 3.).

I. SUMMARY OVERVIEW AND FINDINGS

A. Overview

In its current state, this Investigation involves three (3) Asserted Patents that are owned by a “non-practicing patent assertion entity” or NPAE, Complainant INVT. (*See* Abbreviations, *supra.*) INVT has claimed that the Asserted Patents are standard essential patents or SEPs. SEPs are governed by the European Telecommunications Standards Institute (“ETSI”) which, *inter alia*, are governed by French law, and which create certain obligations for SEPs and for the licensing of SEPS under “fair, reasonable and non-discriminatory” terms, also known by the acronym FRAND.

The Asserted Patents involve 3G and 4LTE communication base station networks that communicate between cell phones or other cellular-configured products. The Accused Products include smartphones, tablets, smart watches, certain computers and other similar devices that are 3G and 4G (also referred to as LTE) compliant and that Respondents Apple, HTC and ZTE manufacture outside the United States, but which they import into and/or sell within the United States. (*See* Representative Product Stipulation at 1-2 (Doc. ID No. 688512 (Sept. 18, 2019); *see also* Section III.A.3, *infra*; Abbreviations, *supra.*) While the Accused Products function using 3G and LTE standards, it is a finding of this initial decision that they do not infringe the Asserted Patents. Additionally, it is a finding of this initial decision that INVT has not proven a violation of Section 337. 19 U.S.C. § 1337.

Among other problems for INVT’s theories of infringement, the initial decision contains a finding that none of the Asserted Patents are standard essential. Additionally, INVT failed to show that the source code in the Accused Products confirms that Apple’s, HTC’s and ZTE’s Accused Products infringe the Asserted Patents. Finally, as Staff has noted, INVT did not show,

Public Version

let alone prove, where the source code for the claimed accused features are to be found in the Accused Products.

Respondents claimed in a somewhat novel theory that if the Accused Products are found to infringe the Asserted Patents and are found to be SEPs, then INVT should be denied a remedy on public interest grounds because INVT allegedly failed to offer the Respondents licenses under FRAND terms. Although this document discusses FRAND briefly under Affirmative Defenses, Section X.D, FRAND will be discussed more thoroughly in a forthcoming document that deals with the public interest and remedy pursuant to 19 C.F.R § 210.42(a)(1)(ii)(A), (B) and (C).

Among other findings of that document that will issue, I have found that even had there been a violation of Section 337, or should the Commission not uphold the findings that there has not been a violation of Section 337, the weight of the evidence supports a finding that INVT did not offer licenses to Respondents Apple, HTC and ZTE on FRAND terms. That said, the remainder of the analysis of the public interest factors and the application of FRAND will follow.

B. Summary Findings

A summary of key findings is contained in Table No. 1:

Table No. 1: Summary of Findings

Products	Patent	Claims	Determination
Accused Products	'587 patent	4	<i>No Violation:</i> Asserted claim 4 of the '587 patent is not invalid but also is not practiced by an Accused Product.
	'590 patent	3, 4	<i>No Violation:</i> Asserted claims 3 and 4 of the '590 patent are not invalid but also are not practiced by

Products	Patent	Claims	Determination
			an Accused Product.
	'439 patent	1, 2	<i>No Violation:</i> Asserted claims 1 and 2 of the '439 patent are not invalid but also are not practiced by an Accused Product.
DI Products	'587 patent	4	<i>Technical DI Not Satisfied:</i> DI Products do not practice claim 4 of the '587 patent.
	'590 patent	3, 4	<i>Technical DI Not Satisfied:</i> DI Products do not practice claims 3 and 4 of the '590 patent.
	'439 patent	1	<i>Technical DI Not Satisfied:</i> DI Products do not practice claim 1 of the '439 patent.
	n/a	n/a	<i>Economic DI Satisfied in the Alternative:</i> if technical DI had been satisfied as alleged by INVT, the economic prong of DI would be satisfied under Sections 337(a)(3)(A) and (a)(3)(B).

II. BACKGROUND

A. Institution and Selected Procedural History

On September 13, 2018, INVT filed a complaint (“Complaint”) under Section 337 of the Tariff Act of 1930, as amended, 19 U.S.C. § 1337, in which it alleges infringement of: claims 3 and 4 of U.S. Patent No. 6,760,590 (“the ’590 patent”); claim 4 of U.S. Patent No. 7,206,587 (“the ’587 patent”); claims 1, 2, and 4 of U.S. Patent No. 7,764,711; claims 1-3 of U.S. Patent No. 7,848,439 (“the ’439 patent”); and claim 16 of U.S. Patent No. 7,339,949. (*See, e.g.,* Compl. at ¶ 1.4 (Doc. ID No. 655702 (Sept. 13, 2018)).).

Public Version

The Commission instituted this Investigation pursuant to subsection (b) of Section 337 of the Tariff Act of 1930, as amended, on October 19, 2018. 83 Fed. Reg. 53105 (Oct. 19, 2018).

The Notice of Investigation (“NOI”) names as complainant: INVT SPE LLC of San Francisco, CA (“Complainant” or “INVT”). *Id.* at 53106. The NOI names as respondents: Apple Inc. of Cupertino, CA (“Apple”); HTC Corporation of Taoyuan City, Taiwan and HTC America, Inc. of Seattle, WA (collectively, “HTC”); and ZTE Corporation of Guangdong Province, China and ZTE (USA) Inc. of Richardson, TX (collectively, “ZTE”, and with Apple and HTC, the “Respondents,” and with Complainant, the “Private Parties”). *Id.* The NOI also names as a party the Office of Unfair Import Investigations (“Commission Investigative Staff” or “Staff”). *Id.*

On November 13, 2018, Respondents separately filed responses to the Complaint and NOI. (Doc. ID No. 661735 (Nov. 13, 2018) (“Apple’s Response”); Doc. ID No. 661757 (Nov. 13, 2018) (“ZTE’s Response”); Doc. ID No. 661734 (Nov. 13, 2018) (“HTC’s Response”).). In its Response, Apple identified twelve (12) affirmative defenses (“Apple’s Affirmative Defenses”). (Apple’s Resp. at 47-56.). In its Response, ZTE identified ten (10) affirmative defenses (“ZTE’s Affirmative Defenses”). (ZTE’s Resp. at 58-62.). In its Response, Apple identified eleven (11) affirmative defenses (“HTC’s Affirmative Defenses”). (HTC’s Resp. at 30-36.).²

² Respondents jointly filed an Initial Post-Hearing Brief in which they identified and discussed only three Affirmative Defenses, all of which were argued during the evidentiary hearing (“Hearing”), although not necessarily in this order: (1) Exhaustion; (2) Unclean Hands; and (3) Estoppel/Waiver. These Affirmative Defenses are discussed in Section X, *infra*. Pursuant to Ground Rule 10.1, Respondents have waived any argument on any other Affirmative Defenses, such as Breach of Non-Disclosure Agreement, which was identified in Respondents’ Pre-Hearing Brief but dropped during the Hearing. (RPBr. at 83-89.). FRAND and Public Interest arguments (some of which are referenced in certain Affirmative Defenses) will be discussed in detail in a forthcoming filing pursuant to 19 C.F.R § 210.42(a)(1)(ii)(A), (B) and (C).

Public Version

On two (2) occasions, an Initial Determination (“ID”) issued granting INVT’s partial termination of this Investigation against Respondents with respect to certain asserted patents and claims, leaving the following patents and claims in this Investigation and subject to this decision: claims 3 and 4 of the ’590 patent; claim 4 of the ’587 patent; and claims 1 and 2 of the ’439 patent. (See Order No. 46 (July 31, 2019); Order No. 20 (Mar. 11, 2019).).

Table No. 2: Asserted Patents and Claims Remaining in This Investigation

Patent No.	Remaining Asserted Claims	Asserted Against
6,760,590	3, 4	All Respondents
7,206,587	4	All Respondents
7,848,439	1, 2	All Respondents

(Order No. 46 at 2 (July 31, 2019).).

On February 28, 2019, the Parties filed a Joint *Markman* Hearing Proposal. (Doc. ID No. 668773 (Feb. 28, 2019).). In the Proposal, INVT and Respondents disagreed over whether a *Markman* hearing would be beneficial, with the former opposing such a hearing and the latter requesting it. (*Id.* at 1-3.). Staff remained neutral. (*Id.* at 3-6.). A *Markman* hearing was held on April 3, 2019. (Doc. ID Nos. 672229 (Apr. 4, 2019) (*Markman* hearing transcript).). On July 15, 2019, a *Markman* Order issued that construed the claim terms in dispute and adopted agreed-upon constructions. (Order No. 14 (“*Markman* Order”) (Mar. 26, 2019).).

INVT filed three (3) motions *in limine* (“MILs”). (Motion Docket Nos. 1138-045 (Aug. 8, 2019), 1138-046 (Aug. 9, 2019), 1138-047 (Aug. 9, 2019).). Respondents filed three (3) MILs. (Motion Docket Nos. 1138-042 (Aug. 8, 2019), 1138-043 (Aug. 8, 2019), 1138-044 (Aug. 8, 2019).).

The identification of INVT’s and Respondents’ MILs and the rulings on their MILs, are summarized in Table Nos. 3 and 4 below.

Table No. 3: INVT’s Three (3) Motions *in Limine*

MIL No.	Issue	Ruling
Motion Docket No. 1138-045, filed on August 8, 2019	Complainant INVT SPE LLC’s Motion <i>in Limine</i> to Preclude Evidence Related to Heather Mewes	Denied: during a telephone conference held on August 27, 2019 (“Aug. 27, 2019, Teleconference”). (Transcript of Aug 27, 2019 Teleconference (“Tel. Tr.”) at 62:25-65:12 (Doc. ID No. 689663 (Sept. 30, 2019))).
Motion Docket No. 1138-046, filed on August 9, 2019	Complainant INVT SPE LLC’s Motion to Accept Complainant INVT’s Motion <i>in Limine</i> to Exclude Evidence and Argument Related to ██████████ Agreements and Undisclosed ██████████ Witness Exhibits Thereto out of Time	<p>Denied-in-part and granted-in-part: (Order No. 51 at 2-3 (Sept. 102, 2019)):</p> <p>Denied: “(a) As previously ordered during the August 27, 2019 Telephone Conference, a non-party ██████████ witness will be permitted to testify during the Hearing with respect to certain ██████████ agreements at issue because a ██████████ was identified on tentative witness lists filed by INVT and Respondents in January 2019....”</p> <p>(b) Denied: “Any ██████████ un-redacted documents that were produced as redacted documents before the close of fact discovery will be allowed to be identified and introduced during the Hearing, subject to appropriate objections.”</p> <p>(c) Granted: “Any other late produced ██████████ documents are precluded.”</p> <p>(d) Granted: ██████████ is precluded because the document was produced far too late; its admission would prejudice all Parties.</p>
Motion Docket No. 1138-047, filed on August 9, 2019	Complainant INVT SPE LLC’s Motion to Accept Complainant INVT’s Motions <i>in Limine</i> to Exclude Undisclosed Intel	Denied: during August 27, 2019 Teleconference. (Aug 27, 2019 Tel. Tr. at 20:214-21:25 (Doc. ID No. 689663 (Sept. 30, 2019))).

Public Version

MIL No.	Issue	Ruling
	Witness and to Preclude Evidence Related to Heather Mewes and Exhibits Thereto Out of Time	

Table No. 4: Respondents’ Three (3) Motions *in Limine*

MIL No.	Issue	Ruling
Motion Docket No. 1138-042, filed on August 8, 2019	Respondents’ Motion <i>in Limine</i> No. 1 to Preclude Reliance on Evidence or Argument Relating to Validity Contentions Withheld During Discovery	Denied: during August 27, 2019 Teleconference. (Aug. 27, 2019 Tel. Tr. at 69:16-19 (Doc. ID No. 689663 (Sept. 30, 2019))).
Motion Docket No. 1138-043, filed on August 8, 2019	Respondents’ Motion <i>in Limine</i> No. 2 to Preclude Exhaustion Arguments Not Raised in Contention Interrogatory Responses	<p>Denied-in-part and granted-in-part: (Order No. 51 at 3.).</p> <p>(a) Granted:</p> <p>“INVT expressly is precluded from relying upon the following, specific late-produced contentions,” in addition to the following:</p> <p>(1) Precluded: INVT’s late argument (and any evidence pertaining thereto) that [REDACTED] sales of components are not covered by the covenant not to assert. INVT’s argument is a contradiction of Ex. 133 to the Complaint.</p> <p>(2) Precluded: INVT’s late argument (and any evidence pertaining thereto) that [REDACTED] chipsets and SoC’s do not substantially embody the asserted claims. This is a contradiction of INVT’s infringement contention.</p> <p>(b) Denied: Not Precluded Provisionally: “Any other ‘late arguments,’ including those provided</p>

Public Version

MIL No.	Issue	Ruling
		for the first time in INVT’s Pre-Hearing Brief, will be admitted provisionally during the Hearing, subject to appropriate objections. It is not clear that other arguments INVT made ‘late’ according to Respondents either in INVT’s Pre-Hearing Brief or in its Opposition to Respondents’ Motion for Summary Determination on Patent Exhaustion, are late or were simply a restatement in another form of INVT’s initial contentions.”
Motion Docket No. 1138-044, filed on August 8, 2019	Respondent Apple Inc.’s Motion <i>in Limine</i> No. 3 to Preclude Reference to the <i>In re</i> [REDACTED]	Denied: during Aug 27, 2019 Teleconference. (Aug.27, 2019 Tel. Tr. at 82:9-16 (Doc. ID No. 689663 (Sept. 30, 2019))).

The evidentiary hearing (“Hearing”) was held on September 12-13, 16-20, and 23, 2019. (Order No. 35 (June 19, 2019)). During or immediately after the Hearing, INVT filed one (1) motion to strike (“MTS”) evidence presented during the Hearing, while Respondents filed five (5) such motions. INVT’s MTS, and the corresponding rulings, are summarized in Table No. 5 below. Respondents’ MTSs, and corresponding rulings, are summarized in Table No. 6 below.

Table No. 5: INVT’s Motions to Strike

Motion	Issue	Ruling
Motion Docket No. 1138-055, filed on	Complainant INVT SPE LLC’s Motion to Strike Dr. Acampora’s ³ Provisional	Denied. (Order No. 56 at 2-3 (Oct. 23, 2019)).

³ When he testified during the Hearing on September 19, 2019, Dr. Anthony Acampora was a Professor of Electrical and Computer Engineering at the University of California, San Diego. (RPSt. at Ex. 1.). Respondents identified Dr. Acampora as an expert to provide testimony about, *inter alia*, non-infringement, the technical prong of the DI requirement, and invalidity of the ’439 patent. (RPSt. at (would be) 2 (document not paginated)).

Public Version

Motion	Issue	Ruling
September 19, 2019	Testimony, Demonstratives, and Related Exhibits in Violation of Order 52	

Table No. 6: Respondents’ Motions to Strike

Motion	Issue	Ruling
Motion Docket No. 1138-052, filed on September 16, 2019	Respondents’ Motion to Strike Dr. Nettleton’s ⁴ Provisional Testimony Offering Previously Undisclosed Opinions and Analysis	Granted. (Order No. 57 at 2-3 (Oct. 23, 2019).). “Respondents’ Motion to Strike Dr. Nettleton’s reference(s) to CX-0470, and Dr. Nettleton’s demonstratives that reference them, and Dr. Nettleton’s Hearing testimony at Tr. at 582:6-585:16, 498:4-501:11, Motion Docket No. 1138-052, is granted. Those pages and lines in the referenced Hearing Transcript are stricken.”
Motion Docket No. 1138-053, filed on September 16, 2019	Respondents’ Motion to Strike Dr. Nettleton’s Provisional Testimony Offering Previously Undisclosed Opinions and Analysis regarding Source Code	Denied. (Order No. 57 at 4-7 (Oct. 23, 2019).).

⁴ Raymond Nettleton wrote his Ph.D. thesis on the use of code-division multiple access (“CDMA”) in cellular communications, “a method of using language in a way that only two people can understand it.” (Tr. (Nettleton) at 503:15-24.). Dr. Nettleton has taught at the university level (e.g., Michigan State) and worked in the industry (e.g., West Advanced Technologies). (*Id.* at 504:23-505:8.). For the last 12 or 13 years, Dr. Nettleton has worked as a testifying expert. (*Id.* at 507:10-14.). Dr. Nettleton was initially called on September 13, 2019, to testify “regarding matters relating to the technical background of the patents asserted in this Investigation; the essentiality of the asserted claims to the 3G and LTE technical standards; the design, structure, function, and operation of the accused products and any article asserted to infringe the asserted patents; the design, structure, function, and operation of domestic industry products, and any research and development asserted to comprise INVT’s domestic industry; the knowledge of a person of ordinary skill in the art; claim construction; and other issues in connection with infringement, validity, the technical prong of the domestic industry requirement, enforceability.” (CPSSt. at 5.).

Public Version

Motion	Issue	Ruling
<p>Motion Docket No. 1138-054, filed on September 17, 2019</p>	<p>Respondents’ Motion to Strike Dr. Vojcic’s⁵ Provisional Testimony Offering Previously Undisclosed Opinions and Analysis</p>	<p><i>Denied-in-part and granted-in-part:</i> (Order No. 57 at 7-9 (Oct. 23, 2019))</p> <p><i>Granted:</i> (a) “In this instance, INVT’s omission, or rather Dr. Vojcic’s omission, is not simply an issue of fitting testimony within the ‘general scope’ of an expert report. EPRE is a specific power concept and characteristic of channel estimating involving downlink power control that can vary depending upon the reference SignalPower. There was a great deal of intense disagreement about whether the Asserted Patents are standard essential (‘SEPs’). The detail is important. Dr. Vojcic should have mentioned/discussed this concept and what it meant in reference to CQI before he chose to discuss it during the Hearing. EPRE is not simply an assemblage of ‘words’ that automatically fall within the ‘scope’ of his report when Dr. Vojcic left this concept out of his expert reports and its relationship to cell-specific reference signals that UE, or user equipment receives. What Dr. Vojcic may or may not have meant by leaving out a discussion of how EPRE cannot be assumed. If EPRE was sufficiently significant to be discussed during the Hearing, then long before the Hearing,</p>

⁵ When he testified during the Hearing on September 16, 2019 and September 23, 2019, Dr. Branimir Vojcic was the President of Xplore Wireless LLC, a telecommunication consulting company and a co-founder, Director, CEO, and CTO of LN2, a startup in the telecommunication industry. (CPSt. at 6, 9; *see also id.* at Ex. B.). INVT identified Dr. Vojcic as an expert to testify about matters relating to the technical background of the patents asserted in this Investigation; the essentiality of the asserted claims to the 3G and LTE technical standards; the design, structure, function, and operation of the accused products and any article asserted to infringe the asserted patents; the design, structure, function, and operation of domestic industry products, and any research and development asserted to comprise INVT’s domestic industry; the knowledge of a person of ordinary skill in the art; claim construction; and other issues in connection with infringement, validity, the technical prong of the domestic industry requirement, enforceability, and/or any other technical issue that may arise.

Public Version

Motion	Issue	Ruling
		<p>Dr. Vojcic should have pointed to EPRE and its relationship to either the 3G or LTE standards as appropriate, in his analysis of CQI. This is not merely an issue that goes to the weight of testimony.</p> <p>Therefore, the foregoing reasons, Respondents Motion, Motion Docket No. 1138-054, is granted in part and denied in part. Accordingly, Dr. Vojcic’s testimony at Hr. Tr. at 795:21-796:16, 815:15816:1 is stricken.”</p> <p>(b) <i>Granted-in part and denied-in part:</i> “INVT may not use the references in CDX-0005C-34, -44 for any purpose. However, because those documents are not evidence, they need not be stricken.”</p>
Motion Docket No. 1138-058, filed on September 24, 2019	Respondents’ Motion to Strike Dr. Nettleton’s Provisional Testimony Offering Previously Undisclosed Opinions and Analysis Regarding Invalidity	<p>Granted. (Order No. 61 at 3 (Feb. 3, 2020).).</p> <p>“Dr. Nettleton's demonstrative slides, CDX-0012.0009-13, the opinions discussed and contained therein, and related testimony at Hr. Tr. 2433:25-2437:19 are also stricken.”</p>
Motion Docket No. 1138-059, filed on September 24, 2019	Respondents’ Motion to Strike Dr. Ryan Sullivan’s Testimony Offering Previously Undisclosed Opinions and Analysis regarding Valuation	<p>Denied. (Order No. 57 at 10-11 (Oct. 23, 2019).).</p>

B. The Parties

1. Complainant INVT SPE LLC

INVT is a limited liability company organized and existing under the laws of the State of Delaware, having its principal place of business in San Francisco, California. (Compl. ¶ 2.1.).

Public Version

INVT has two members, CF INVT Holdings LLC and Inventergy, Inc. (*Id.*; JX-0012 (INVT LLC Agreement) ¶ 3.1 (referencing Schedule 3.1)). CF INVT Holdings LLC is the Managing Member of INVT. (JX-0012 (INVT LLC Agreement) at Preamble, ¶ 7.1.). According to INVT, it is “in the business of investment and licensing to help industry leaders protect their most valuable intellectual property.” (Compl. ¶ 2.2.). In other words, INVT is a non-practicing patent assertion entity (“NPAE”) that monetizes its patent portfolio.⁶

2. Respondent Apple

Apple is a corporation existing under the laws of the State of California, with a principal place of business in Cupertino, California. (RPBr. at 2.). Apple designs, supplies, and markets personal and tablet computers, mobile communication devices, and portable digital music and video players, and sells a variety of related software, services, peripherals, and networking solutions. (*Id.*). Apple employs 90,000 people in the U.S. and works with over 9,000 U.S. suppliers. (*Id.* at 2-3).

3. HTC Respondents

HTC Corporation, organized and existing under the laws of Taiwan R.O.C., has a principal place of business in Taiwan. (RPBr. at 3.). “HTC Corporation is either directly, or

⁶ INVT states that Inventergy previously owned the Asserted Patents. (Compl. ¶ 1.3.). The Asserted Patents were initially assigned to Panasonic Corp. (formerly Matsushita Electric Industrial Co., Ltd.). (JX-0001-0003; JX-0002-0003; JX-0003-0003; JX-0005; JX-0006; JX-0007; JX-0008.). On October 21, 2013, Panasonic assigned the Asserted Patents to Inventergy. (JX-0009C; JX-0010C; JX-0011C.). Investments in Inventergy by Fortress Investment Group (“Fortress”), a hedge fund, enabled Inventergy to enforce its patent portfolio, including the Asserted Patents. (Order No. 26 at 1-2 (Apr. 3, 2019) (requiring INVT’s production of documents for *in camera* review).). However, when Inventergy’s patent monetization strategy [REDACTED] Fortress proposed [REDACTED] (RX-1459C.0001.). On April 27, 2017, Inventergy assigned the Asserted Patents (and many other patents) to INVT. (JX-0013; JX-0005.). Against this backdrop, as INVT states, for purposes of FRAND, the activities of INVT and Inventergy are considered one in the same because INVT stepped into the shoes of Inventergy after INVT took ownership of the Asserted Patents. (CBr. at 16 n.10.).

Public Version

indirectly through one of its subsidiaries, responsible for designing, developing, manufacturing, cellular communication devices that use third-party baseband processors.” (*Id.*). HTC America, Inc. is a corporation organized and existing under the laws of Washington, with a principal place of business in Seattle Washington. (*Id.*). HTC America, Inc. imports cellular communication devices into the United States manufactured by HTC Corporation, and/or sells such cellular communication devices in the United States after importation. (*Id.*).

4. ZTE Respondents

ZTE (USA), Inc., a corporation organized and existing under the laws of New Jersey, is headquartered in Richardson, Texas. (ZTE Resp. at 7.). ZTE (USA) Inc. imports the Accused Devices into the United States, sells the Accused Devices in the United States after importation, is engaged in services related to the importation into the United States of Accused Products, including the marketing and after-sale service of the Accused Products. (ZTE Resp. at 8.). ZTE (USA), Inc. is a subsidiary of ZTE Corporation, a global provider of mobile devices, telecommunication systems, and enterprise solutions, which was founded in 1985. (RPBr. at 3.).

III. JURISDICTION, IMPORTATION, AND STANDING⁷

A. The Commission Has Jurisdiction

To have the authority to decide a case, a court or agency must have both subject matter jurisdiction and jurisdiction over either the parties or the property involved. *See Certain Steel*

⁷ Respondents do not contest that the Commission has (i) personal jurisdiction over the Respondents; (ii) subject matter jurisdiction over the issues set forth in the Notice of Investigation; and (iii) *in rem* jurisdiction over the Accused Products. INVT and Respondents executed Importation Stipulations with respect to importation of the Accused Products. (*See* EDIS Doc Nos. 674030 (ZTE) and 674545 (HTC).) *See also*, the Importation Stipulations between INVT and Apple Inc. that was filed July 24, 2019 in addition to those that INVT signed with ZTE and HTC. (*See* JX-0022 (ZTE); JX-0023 (HTC); JX-0024 (Apple); *see also* RPBr. at 5.). However, Respondents do contest whether INVT has standing. (RBr. at 1.).

Public Version

Rod Treating Apparatus and Components Thereof, Inv. No. 337-TA-97, Comm’n Opinion, 215 U.S.P.Q. 229, 231 (U.S.I.T.C. 1981). For the reasons discussed below, the facts support a finding that the Commission has jurisdiction over this Investigation.

1. The Commission Has Subject Matter Jurisdiction

The Commission has subject matter jurisdiction over this Investigation because INVT alleged that Apple, HTC, and ZTE have violated 19 U.S.C. §1337(a)(1)(B). *See Amgen v. U. S. Int’l Trade Comm’n*, 902 F.2d 1532, 1536 (Fed. Cir. 1990); (Compl. ¶ 1.5.). Respondents do not contest the Commission’s subject matter jurisdiction. (RPBr. at 5.).

2. The Commission Has Personal Jurisdiction

The Commission has personal jurisdiction over Respondents. Respondents do not contest the Commission’s personal jurisdiction over them. (RPBr. at 5 (“Respondents do not contest that the Commission has (i) personal jurisdiction over the Respondents[.]”).). Moreover, Respondents all appeared and responded to the Complaint and NOI, and fully participated in this Investigation, which included participating in discovery and the Hearing. *See, e.g., Certain Microfluidic Devices* (“*Microfluidic Devices*”), Inv. No. 337-TA-1068, Initial Determination, 2018 WL 5279172, at *16 (Sept. 20, 2018); *Certain Windshield Wiper Devices and Components Thereof* (“*Wiper Devices*”), Inv. No. 337-TA-881, Initial Determination at 5 (May 8, 2014) (unreviewed in relevant-part) (Doc. ID No. 534255).

3. The Commission Has *In Rem* Jurisdiction

Section 337(a)(1)(B) applies to the “[t]he importation into the United States, the sale for importation, or the sale within the United States after importation” of articles that infringe a valid and enforceable United States patent.” 19 U.S.C. § 1337(a)(1)(B). A single instance of importation is sufficient to satisfy the importation requirement of Section 337. *Certain Optical*

Public Version

Disc Drives, Components Thereof, and Prods. Containing the Same, Inv. No. 337-TA-897, Order No. 101 at 3 (Sept. 22, 2014) (citations omitted) (EDIS Doc. 543438).

The Private Parties stipulated that the Commission has *in rem* jurisdiction over the Accused Products insofar as each Accused Product was imported into the United States. (JX-0022 (INVT and ZTE Importation Stipulation); JX-0023 (INVT and HTC Importation Stipulation); JX-0024 (INVT and Apple Importation Stipulation)). *See, e.g., Wiper Devices*, Inv. No. 337-TA-881, Initial Determination at 5 (*in rem* jurisdiction exists when importation requirement is satisfied). Staff concurred. (SBr. at 22-23.).

B. INVT Has Standing in the Commission

Jurisdiction also requires standing. *See SiRF Technology, Inc. v. Int'l Trade Comm'n*, 601 F.3d 1319, 1326 (Fed. Cir. 2016) (standing to bring an infringement suit is the same under Commission Rules as it would be in a Federal District Court case); *Certain Optical Disc Drives, Components Thereof and Prods. Containing Same*, Inv. No. 337-TA-897, Opinion Remanding the Investigation at 4 (Jan. 7, 2015). Commission Rule 210.12 requires that intellectual property-based complaints filed by a private complainant “include a showing that at least one complainant is the owner or exclusive licensee of the subject intellectual property.” 19 C.F.R. § 210.12(a)(7).

The Parties raised a dispute over INVT’s standing to file its Complaint. INVT argued that it has standing “because it held all or substantially all right, title, and interest in and to the Asserted Patents.” (CBr. at 14.). In contrast, Respondents and Staff argued that INVT lacked standing because [REDACTED]. (RBr. at 1-2 [REDACTED]). [REDACTED]; *see also* SBr. at 23-25 [REDACTED].

[REDACTED]

[REDACTED]).

On the question of standing, three (3) essential agreements are at issue here: (i) the Agreement Assigning Patent Rights from Inventergy to INVT (“Patent Assignment Agreement”), JX-0013; (ii) the INVT SPE LLC Agreement (“INVT LLC Agreement”), JX-0012; and (iii) the [REDACTED] (“Samsung Patent License Agreement”), JX-0016C.

With respect to the Patent Assignment Agreement, INVT argued that “[t]he Asserted Patents were assigned to INVT on April 27, 2017 through the Patent Assignment Agreement.” (*Id.* at 4 (citing JX-0013 (Patent Assignment Agreement)).)

With respect to the INVT LLC Agreement, Respondents argued that the INVT LLC Agreement grants to CF INVT Holdings LLC certain rights in the Asserted Patents including the “exclusive ability to initiate, direct, terminate, conclude, or negotiate the assignment, sale, or license of any of INVT’s patents, or initiate enforcement, litigation, arbitration, or enforcement.” (RBr. at 1.). Staff joined the premise of Respondents’ argument and argued more precisely that the activities granted to CF INVT Holdings LLC by the INVT LLC Agreement “represent ‘all substantial rights’ in the asserted patents, and the agreement makes clear that these rights were transferred to ... CF INVT Holdings, LLC.” (SBr. at 25.).

With respect to the Samsung Patent License Agreement (JX-0016C), Respondents also contended that the document additionally [REDACTED]

[REDACTED]

[REDACTED]. (RBr. at 2.). However, to the contrary, Staff did not rely on the Samsung Patent License Agreement at all to support its position that INVT lacks standing. (SBr. at 23-25.). For reasons

Public Version

explained below, it is a finding here that the ownership of the Asserted Patents is governed primarily by the Patent Assignment Agreement (JX-0013).

A closer analysis and comparison of the language in each of the three (3) agreements supports a finding that INVT is the sole owner of the Asserted Patents. The Patent Assignment Agreement was executed on April 27, 2017 and states that Inventergy “does hereby: ... SELL, ASSIGN and TRANSFER to ASSIGNEE [INVT] the entire right, title and interest in and to in the patents and patent applications listed,” and proceeds to list the Asserted Patents. (JX-0013 (Patent Assignment Agreement) at 1.). In comparison, the INVT LLC Agreement, also executed on April 27, 2017, states in Section 7.1 that the “Managing Member” CF INVT Holdings LLC:

shall have the exclusive power and authority to *manage* the business, affairs, and assets of the Company [INVT] and to *make all decisions* with respect thereto, including, without limitation, the exclusive power and authority to *make any and all decisions*, in any manner it sees fit, relating to, and shall otherwise fully, solely, absolutely and irrevocably control in all respects, the Patents and any Monetization Activities....

(See JX-0012 (INVT LLC Agreement) at 10 (emphases added).).

However, Section 2.6 of the INVT LLC Agreement grants INVT the “power and authority” to “sue,” “litigate,” and “negotiate, enter into, [and] ... execute ... licenses” (*Id.* at 4-5). The [REDACTED] Samsung Patent License Agreement states that [REDACTED] [REDACTED] (emphasis added). (JX-0016C (Samsung Patent License Agreement) at 16.).

There is no language in any of the agreements that “sells, assigns, transfers” *ownership* of the Asserted Patents to any other party but INVT. Moreover, even if the INVT LLC Agreement or Samsung Patent License Agreement had language sufficient to constitute a valid patent assignment, it would be void compared to the assignment of record under 35 U.S.C. § 261

Public Version

because there is no record that any of these agreements were recorded with the USPTO.⁸

Therefore, ownership of the Asserted Patents remains with INVT, and CF INVT Holdings LLC need not have been joined as a complainant for INVT to have standing.

Respondents and Staff in their arguments appear to confuse a legal “right” with legal “authority.” Respondents and Staff argued, in essence, that the INVT LLC Agreement assigned all or substantially all right, title, and interest in and to the Asserted Patents to CF INVT Holdings LLC. *See Intellectual Property Development, Inc. v. TCI Cablevision of Cal., Inc.*, 248 F.3d 1333, 1346-48 (Fed. Cir. 2001). However, this argument is simply not supported by the language of the three (3) agreements at issue here. The only agreement that “assigns” a “right” in ownership to the Asserted Patents is the Patent Assignment Agreement between Inventergy and INVT. The INVT LLC Agreement merely grants “exclusive power and *authority to manage...and to make all decisions...*” (JX-0012 (INVT LLC Agreement) at 10 (emphases added)). The assignment of ownership of the Asserted Patents to INVT, and the grant of management and decision-making authority to CF INVT Holdings LLC do not contradict one another and represent a rather straightforward legal framework: as the assignee, INVT exclusively holds the *right* to sue, but as the Managing Member, CF INVT Holdings LLC exclusively holds the power to *decide* to exercise INVT’s right to sue. In other words, while INVT cannot exercise their right to sue without first consulting CF INVT Holdings LLC, a subsequent infringement lawsuit approved by CF INVT Holdings LLC must still be in the name of INVT. Indeed, that appears to be the exact situation here.

⁸ “An interest that constitutes an assignment, grant or conveyance shall be void as against any subsequent purchaser...unless it is recorded in the Patent and Trademark Office within three months from its date.” 35 U.S.C. § 261.

Public Version

INVT provided extensive post-hearing briefing on authorities expressly holding that such a management entity, such as CF INVT Holdings LLC, would explicitly *lack* standing in such a situation. (CBr. at 11-12 (citations omitted)). By contrast, neither Respondents nor Staff cited any binding authority that requires a management entity to join as a named complainant to a patent infringement case where the patent assignee is already a named complainant.

Respondents relied upon *State Contracting & Eng'g Corp. v. Condotte Am., Inc.*, 346 F.3d 1057, 1062 (Fed. Cir. 2003) (“*State Contracting*”) to support their position that INVT lacks standing. However, Respondents’ reliance is misplaced. In *State Contracting*, defendants alleged that the plaintiff (State Contracting) lacked standing because the language of assignment executed to transfer the asserted patents from a prior entity (State Paving) to State Contracting was incomplete, and State Paving was not joined as a plaintiff. (*Id.* at 1062.). Thus, the situation in *State Contracting* is different from the situation in this case, as are the seminal agreements. The INVT LLC Agreement did not serve to assign or transfer patent *ownership* from INVT to CF INVT Holdings LLC. Indeed, INVT executed the Patent Assignment Agreement with Inventergy on the same day in order to obtain patent ownership from Inventergy. Rather, the INVT LLC Agreement served only to grant decision-making power and authority to the Managing Member, CF INVT Holdings LLC.

Moreover, in *State Contracting*, the Federal Circuit held that the plaintiff had standing because the language⁹ of the assignment agreement had “the effect of conveying full legal title in the patents to State Contracting.” *State Contracting*, 346 F.3d at 1062. The operative language

⁹ In *State Contracting*, the assignment agreement specified that State Paving “sells, assigns, and transfers” to State Contracting the “entire right title and interest in the inventions...and subject matter disclosed in [the asserted patents].” *State Contracting*, 346 F.3d at 1062.

Public Version

of the assignment in *State Contracting* nearly mirrors the operative language of the Patent Assignment Agreement here. (See JX-0013 (Patent Assignment Agreement) at 1.). As such, any agreement having *less* specific language about patent rights and ownership would accordingly carry less weight than the Patent Assignment Agreement here. Any argument that the *general* management authority to “make all decisions” in the INVT LLC Agreement is more substantial than the *specific* assignment of patent “right to sue” in the Patent Assignment Agreement is simply nonsensical.

Furthermore, if the theory Respondents and Staff advanced were true, CF INVT Holdings LLC could presumably license its rights to the Asserted Patents on its own accord as opposed to on behalf of INVT. Yet, the INVT LLC Agreement does not appear to support such a transfer of rights. Instead, the INVT LLC Agreement states that CF INVT Holdings has the power “to manage the business, affairs, and assets of the company and to make all decisions with respect thereto.” (JX-0012 (INVT LLC Agreement) at 10.). Section 7.2 of the INVT LLC Agreement states that CF INVT Holdings LLC can delegate its powers to officers of INVT. (*Id.* at 11.). The INVT LLC Agreement gives CF INVT Holdings LLC “exclusive power and authority” over the operations of INVT, including the use of INVT’s patent assets to achieve INVT’s business goals. That is authority to extend to CF INVT Holdings LLC the authority to make decisions acting outside of its role as Managing Member of INVT.

Thus, the CF INVT Holdings LLC Agreement does not deprive INVT of all or substantially all right, title, and interest in and to the Asserted Patents. Instead, the Agreement concentrates authority over such “right, title, and interest” within INVT and, in particular, with INVT’s Managing Member.

Respondents advanced a second argument for INVT’s lack of standing based upon the

Public Version

Samsung Patent License Agreement. (RBr. at 2.). However, Respondents' second argument also falls flat. Respondents contended that INVT's rights are also limited by [REDACTED]

[REDACTED]. (*Id.*). The Samsung Patent License Agreement [REDACTED] (JX-0016C (Samsung Patent License Agreement) at 16.). According to Respondents, the Samsung Patent License Agreement thus deprives INVT of substantially all right, title, and interest in and to the Asserted Patents such that INVT lacks standing here.¹⁰ (RBr. at 2.).

Respondents' second argument is inconsistent with Federal Circuit precedent. *See Vaupel Textilmaschinen KG v. Meccanica Euro Italia S.P.A. ("Vaupel")*, 944 F.2d 870, 875 (Fed. Cir. 1991) (sublicensing veto power did not impact patent owner's standing because it was a "minor derogation from the grant of rights" and "did not substantially interfere with the full use ... of the exclusive rights under the patent"). In *Vaupel*, a patent licensing agreement gave the licensee the status of assignee, including standing to bring an infringement action. (*Id.* at 875-76.). That was so notwithstanding: (1) retention by the assignor (the inventor) of the right to veto sublicensing by the assignee; and (2) provisions limiting the agreement's scope to the United States. (*Id.*).

Vaupel is instructive here. Like the licensee in *Vaupel*, under the Samsung Patent

¹⁰ It bears noting that Respondents' standing arguments are inconsistent. If INVT had relinquished substantially all right, title, and interest in and to the Asserted Patents to CF INVT Holdings LLC in the INVT LLC Agreement dated April 27, 2017, INVT presumably would not have been within its rights to license the Asserted Patents to Samsung in the Samsung Patent License Agreement dated [REDACTED]. In other words, Respondents can make their standing arguments in the alternative but not together.

Public Version

License Agreement between INVT and Samsung, INVT retained most, but not all, of its rights¹¹ related to the Asserted Patents. There is no indication that INVT abdicated its right to bring an infringement action against the Respondents. In fact, the Samsung Patent License Agreement contemplates that [REDACTED] [REDACTED]. (JX-0016C (Samsung Patent License Agreement at ¶ 3.3.)). [REDACTED], as was the case in *Vaupel*. Instead, INVT agreed to something arguably less onerous, namely that [REDACTED] [REDACTED]. (*Id.* ¶ 6.2) (emphasis added).)

Based on the interpretation of the various agreements discussed, it is a finding of this decision that INVT did not relinquish all or substantially all right, title, and interest in and to the Asserted Patents. Consequently, it is a finding that INVT has standing in this Investigation.

IV. THE ASSERTED PATENTS

A. Overview of the '587 and '590 Patents

The '590 and '587 patents share the same specification because the '587 patent issued from a continuation of the application that issued as the '590 patent. (JX-0002 ('587 Patent) at 1.). The shared specification of the '590 and '587 patents recognizes that, “[i]n a cellular communication system, one base station performs radio communication with a plurality of communication terminals simultaneously.” (*Id.* at 1:15-17.). Initially, “the base station transmits a pilot signal to each communication terminal. Each communication terminal estimates the downlink channel quality using a CIR (desired carrier to interference ratio) based on the pilot

¹¹ For example, INVT [REDACTED]

Public Version

signal, etc., and finds a transmission rate at which communication is possible.” (*Id.* at 1:30-35.). “[B]ased on the transmission rate at which communication is possible, each communication terminal selects a communication mode, which is a combination of packet length, coding method, and modulation method, and transmits a data rate control [referenced *infra* a “DRC”] signal that indicating communication mode to the base station.” (*Id.* at 1:35-41.).

The DRC signal is important because, as shown below in Figure 1, “[g]enerally, taking improvement of system transmission efficiency into consideration, communication resources are allocated with priority to the communication terminal that has the best downlink channel quality—that is to say, the communication terminal that transmits the highest-numbered DRC signal.” (*Id.* at 1:62-67.). Also, “if the communication mode determined by a communication terminal is received erroneously by the base station, there will be an interval during which time-divided communication resources are not used, and downlink throughput falls.” (*Id.* at 2:29-33.). “[T]he communication terminal cannot demodulate or decode the data.” (*Id.* at 2:21-22.).

Figure 1: Figure 1 of the '590 and '587 Patents

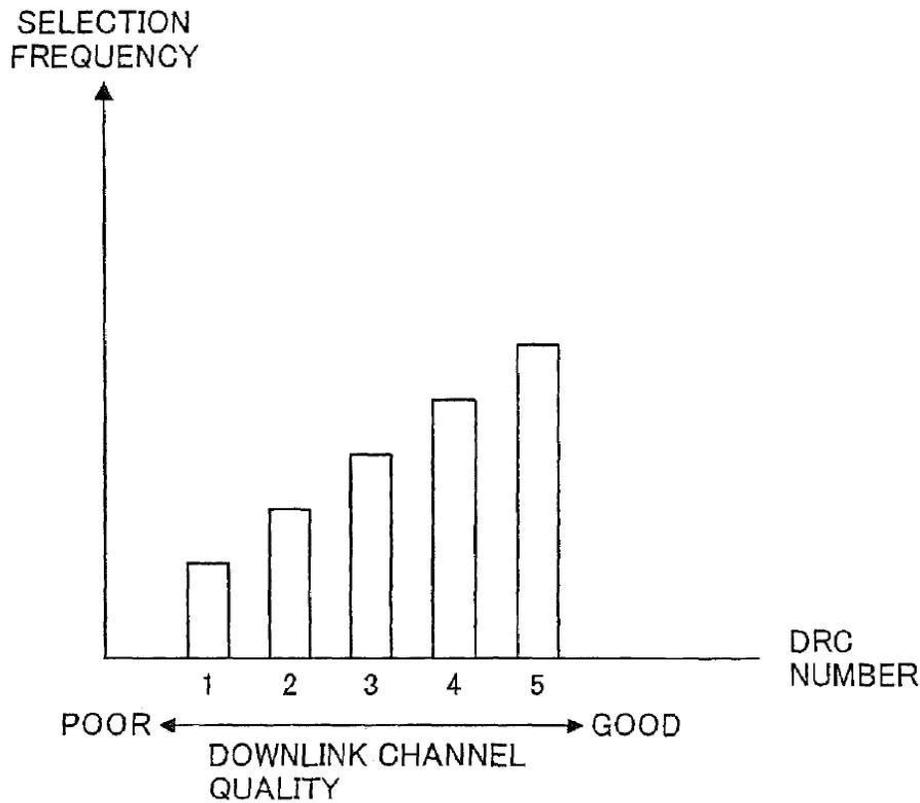

(*Id.* at Fig. 1.).

To guard against such a problem as described in the preceding paragraph from occurring, the '590 and '587 patents disclose encoding the channel quality information to reduce the likelihood of a base station receiving erroneous channel quality information from a communication terminal. (*Id.* at 2:44-52; 20:4-9.). For example, the '590 and '587 patents recognize that, in terms of error protection, some bits are more important than others in a channel quality reading. (*Id.* at 19:39-54.). “If a CIR value is indicated by a value with a decimal fraction (such as 8.7 dB) ... the amount of change per unit of the integer [bit] is 1 dB, while the amount of change per unit of the fractional [bit] is 0.1 dB[.]” (*Id.* at 19:42-46.). This means that, “if an integer part is received erroneously by a base station, the degree of error is large compared

with the case where a fractional part is received erroneously[.]” (*Id.* at 19:49-51.). In other words, in terms of error protection, the integer bit is more “significant” than the fractional bit.

The ’590 and ’587 patents disclose various embodiments that purportedly reduce the likelihood of a base station receiving erroneous channel quality information. For example, in one embodiment for a CIR value of 8.7 dB, “[t]he 6-bit coding section 1203 converts the value output from the upper digit information generation section 1201 (here, ‘8’) to a 6-bit code word,” while the “4-bit coding section 1204 converts the value output from the lower digit information generation-section 1202 (here, ‘7’) to a 4-bit code word,” “assum[ing] that the number of bits that can be used to indicate a CIR value is ten.” (*Id.* at 2:35-50.). In other words, the integer gets encoded with more precision.

B. Overview of ’439 Patent

The ’439 patent relates to an orthogonal¹² frequency division multiplexing (OFDM) system. (JXM-0005 (’439 Patent) at 1:12-14.). The ’439 patent describes such a system adapting to changing channel conditions by modifying the modulation and coding parameters based on the estimated channel quality, a technique known as adaptive modulation and coding (referenced, *infra*, as AMC). (*Id.* at 1:34-40.). To reduce interference, “OFDM¹³ systems transmit high-speed data using a large number of subcarriers that are orthogonal[.]” (*Id.* at 1:19-21.). As shown below in Figure 2, in conventional OFDM systems, “all of the subcarriers on the

¹² Dr. Stephen Wicker, an expert for Respondents, addressed the concept of orthogonality in his book, *Error Control Systems for Digital Communication and Storage*: “A Hadamard matrix of order n is an $(n \times n)$ matrix of + 1s and - 1s such that any pair of distinct rows is orthogonal (i.e., their inner product is zero).” (RX-1766.0145.).

¹³ “OFDM technology theory is transmitting high-speed data using a large number of subcarriers that are orthogonal, and data rates of the subcarriers are relatively low. Compared to a typical frequency division multiplexing system, orthogonality of a sub-carrier in OFDM improves spectral efficiency of the system.” (JX-0003 (’439 patent) at 1:18-24.).

OFDM frequency domain are divided into several subbands,” totaling N in number. (*Id.* at 2:19-21.).

Figure 2: Figure 2 of the '439 Patent

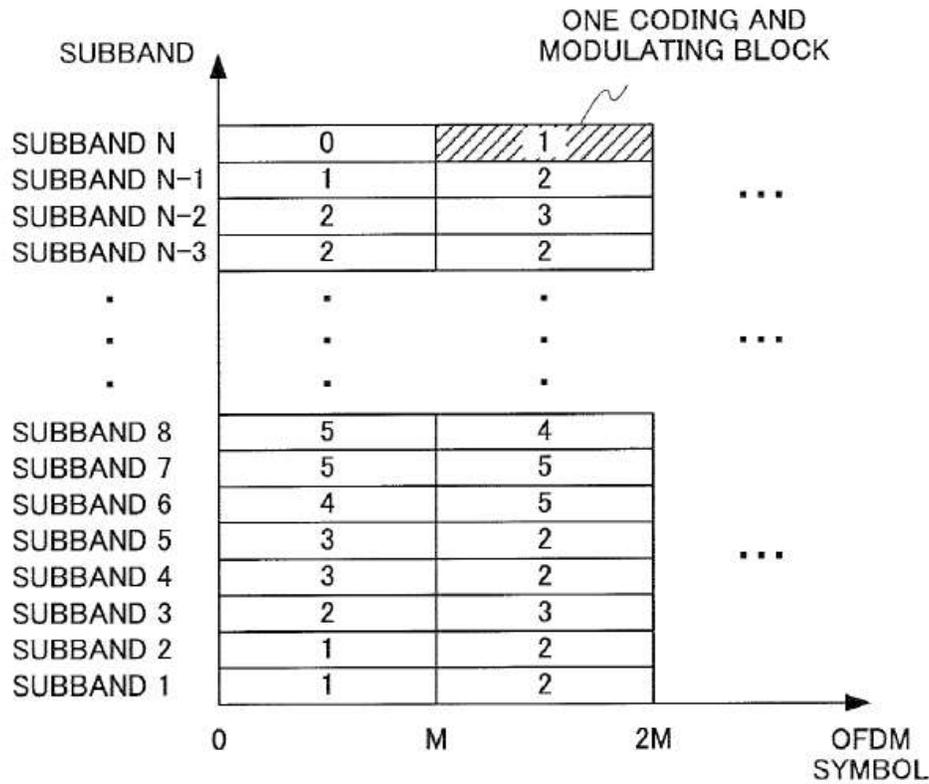

(*Id.* at Fig. 2.).

“Currently [in the prior art], as an adaptive configuration, AMC in OFDM is divided into ... AMC based on subcarriers and AMC based on subbands.” (*Id.* at 2:2-4.). According to the '439 patent, “AMC based on subcarriers is very difficult to be implemented, and, in addition, has the problem that feedback overhead is too large.” (*Id.* at 2:8-11.). “Compared to subcarrier adaptivity, the adaptive method using independent coding of subbands ... is able to effectively reduce the difficulty of implementation of adaptivity and is able to effectively reduce feedback overhead of the system. However, even in this kind of method, there is the drawback that it is

Public Version

not possible to effectively utilize diversity performance between the subbands.” (*Id.* at 2:56-63.).

The '439 patent purports to solve the problem described above. Specifically, the '439 patent proposes “combining all of the subbands on a frequency domain of a subcarrier communication system based on a fixed rule ... to give several subband groups, and then selecting modulation and coding parameters for use during joint coding with respect to *each subband group.*” (*Id.* at 5:40-44 (emphasis added)). In other words, a device selects a single set of modulation and coding parameters for each subband group, and then uses those parameters to decode information received on those subbands. (*Id.* at 5:32-44.). Another way of framing the “invention” is that the '439 patent extends AMC based on subcarriers and subbands as found in the prior art to AMC based on subband groups.

Figure 3 below depicts three (3) different ways of combining subbands to form subband groups. The first way “shows an example of combining neighboring subbands.” (*Id.* at 10:38-39.). The second way shows “shows an example of combining subbands spaced at intervals.” (*Id.* at 10:55-56.). The third way “is an example of combining all of the subbands.” (*Id.* at 10:66-67.).

Figure 3: Figures 8 -10 of the '439 Patent Showing Formation of Subband Groups

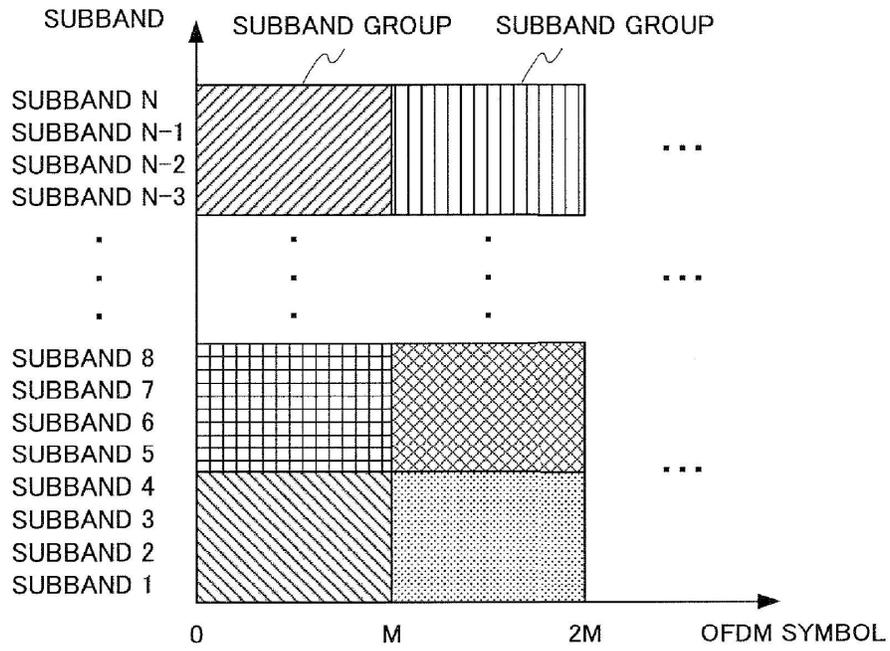

FIG.8

(*Id.*, Figs. 8-10.).

V. THE PRODUCTS AT ISSUE

The Accused Products comprise certain personal electronic devices that are compliant with the LTE and/or 3G 3GPP specifications, and which enable LTE and/or 3G data transfer and communications.¹⁴ (NOI at 53105.). As shown below in Figure 4, the Accused Products include LTE- and 3G-compliant cellular phones, tablet computers, and smartwatches. (Compl. ¶ 1.1.). The Parties stipulated to the use of Representative Products. (*See* Representative Product Stipulation at 1-2 (Doc. ID No. 688512 (Sept. 18, 2019)) (identifying both “representative” and “represented” Accused Products for each Respondent).).

¹⁴ Both 3G, the third generation of wireless mobile telecommunications technology, and 4G or 4LTE, i.e. the fourth generation, can transmit (e.g., upload and download) data. (Compl. ¶ 4.10.). Data are used for applications such as connecting to the Internet, streaming videos, email, and at times, for voice calls (e.g., Voice over LTE or “VoLTE”). (*Id.*). 3G technologies for transmitting data include the Universal Mobile Telecommunications System (“UMTS”) standard. (*Id.*). UMTS includes Wideband Code Division Multiple Access (“WCDMA”), High Speed Packet Access (“HSPA”), and HSPA+ standards. HSPA+ is an advancement on HSPA, and as such, incorporates and builds upon the full HSPA standard. 4G technologies for transmitting data include Long Term Evolution (LTE) and Long Term Evolution-Advanced (“LTE-A,” also referred to as “LTE+”) standards. (*Id.*). LTE+ is an advancement on LTE, and as such, incorporates and builds upon the full LTE standard. (*Id.*). These industry-developed standards are administered by the European Telecommunications Standards Institute (“ETSI”). (*Id.* ¶ 4.12.). ETSI (which is discussed briefly in Section VII.A.1) is one of six (6) standards-setting organizations that have formed the Third Generation Platform Partnership (“3GPP”), which sets standards for mobile wireless carrier technology, including for the LTE and 3G standards in this Investigation, which are themselves separate standards. (*Id.*).

Figure 4: Respondents’ Depiction of Accused Products

- Apple, HTC, and ZTE products that are compatible with the 3G and LTE standards
 - User equipment including smartphones, tablets, and watches



(RDX-0005C.0029 (introduced during the testimony of Dr. Wicker)).¹⁵

A. Apple’s Accused Products

“Apple and INVT stipulate that any finding by the ALJ regarding infringement or non-infringement of the Asserted Patents by the **Representative Product iPhone 8 A1863** shall apply to the following Accused Apple Products: iPad Mini 4 A1550; iPad Pro 10.5 A1709; iPhone 7 A1660; iPhone 7 Plus A1661; iPhone 8 A1863; iPhone 8 Plus A1864; iPhone X A1865; Apple Watch Series 3 A1860; Apple Watch Series 3 A1861; iPad 9.7” 6th Generation A1954.” (Representative Product Stipulation ¶ 2.). An exemplary Apple Accused Product is shown below in Figure 5.

“Apple and INVT stipulate that any finding by the ALJ regarding infringement or non-

¹⁵ Stephen B. Wicker, PhD initially testified at the Hearing on September 18, 2019, as Respondents’ technical expert for the ’587 and ’590 patents. At that time, Dr. Wicker was a professor of electrical and computer engineering at Cornell University in Ithaca, New York, with expertise in telecommunications, primarily wireless communications. (Tr. (Wicker) at 1433:1-10.). With respect to the ’587 and ’590 patents, Respondents expected Dr. Wicker to testify about non-infringement of the Accused Products, domestic industry technical prong, invalidity over the prior art, and knowledge and level of ordinary skill in the art at the time of the alleged invention. (RPSt. at 3.).

Public Version

infringement of the Asserted Patents by the **Representative Product iPhone XS A1920** shall apply to the following Accused Apple Products: iPhone 7 A1778; iPhone 7 Plus A1784; iPhone 8 A1905; iPhone 8 Plus A1897; iPhone X A1901; iPhone XR A1984; iPhone XS Max A1921; iPad Pro 11” A2013; iPad Pro 12.9” A2014; iPad Air (2019) A2123; iPad Mini (2019) A2124; Apple Watch Series 4 A1975; and the Apple Watch Series 4 A1976.” (*Id.* ¶ 3.).

Figure 5: Photograph of Exemplary Apple Accused Product (iPhone X (Model No. A1865))



(Compl., Ex. 126.).

B. HTC’s Accused Products

“HTC and INVT stipulate that any finding by the ALJ regarding infringement or non-infringement of the Asserted Patents by the **Representative Product HTC U11** shall apply to the following Accused HTC Products: U11 Life; U12+; Exodus 1; and the HTC 5G Hub RTX.” (Representative Product Stipulation ¶ 4.). An exemplary HTC Accused Product is shown below in Figure 6.

Figure 6: Photograph of Exemplary HTC Accused Product (HTC U11)



(Compl., Ex. 127.).

C. ZTE's Accused Products

“ZTE and INVT stipulate that any finding by the ALJ regarding infringement or non-infringement of the Asserted Patents by the **Representative Product ZTE Max XL** shall apply to the following Accused ZTE Products: Boost Max (N9520); Sonata 4G (Z740G/Z740); Grand Memo 2(Z980L); Concord II (Z730); Altair (Z431); Grand S Pro (N9835); Compel (Z830); Zmax (Z970); Grand X Max (Z787); Prelude 2 (Z669); Zinger (Z667T); Altair 2 (Z434); Lever

Public Version

(Z936L); Speed (N9130); Grand X Max+ (Z987); Imperial II (N9101); Paragon (Z753G); Overture 2 (Z813); Sonata 2 (Z755); Maven (Z812); Boost Max+ (N9521); Warp Elite (N9518); Max Duo LTE (Z962BL); Obsidian (Z820); Prestige (N9132); Avid Plus (Z828); Imperial Max (Z963U); Grand X Max 2 (Z988); Axon 7 (A2017U); Midnight Pro (Z828TL); Sonata 3 (Z832); Zmax Grand (Z916BL); Zmax Pro (Z981); Zmax Champ (Z917VL); Zfive L LTE (Z861BL); Warp 7 (N9519); Grand X 4 (Z956); Cymbal-T LTE (Z233V); Fanfare 2 (Z815); Cymbal (Z320); Axon 7 Mini (B2017G/A7S); Cymbal LTE (Z233V); Avid Trio (Z833); Majesty Pro (Z798BL); Blade V8 Pro (Z978); Prestige 2 (N9136); Blade Max 3 (Z986U); Avid 916 (Z916); Jasper (Z718TL); Blade Spark (Z971); Blade X Max (Z983); Cymbal-G LTE (Z232TL); ZFive 2 LTE (Z837VL); Maven 2 (Z831); Maven 3 (Z835); Blade Z Max (Z982); Max Blue (Z986DL); Blade Vantage (Z839); Tempo X (N9137); Tempo Go (N9137); Avid 828 (Z828); Axon M (Z999); Blade Max 2S (Z6410S); Blade Max View (Z610DL); Quartz Smart Watch (ZW10); Aspect (F555); Avid 4 (Z855); Axon (A1R); Axon 7 Mini.(A7S); Axon Pro (A1P); Blade Force (N9517); Blade X (Z965); Boost Force (N9100); Boost Warp 4G (N9521); Citrine (Z717BL); Cymbal-T (Z353VL); Fanfare 3 (Z852); Grand X 3 (Z959); Majesty Pro (Z799VL); Majesty Pro Plus (Z899VL); Max Duo LTE (Z963BL/Z963VL); Overture 3 (Z851M); Primetime (K92); Stratos (Z819L); Trek 2 HD (K88); ZFive G (Z557BL); ZFive L (Z861BL); ZFive L LTE (Z862VL); and Zmax 2 (Z955).” (Representative Product Stipulation ¶ 5.). An exemplary ZTE Accused Product is shown below in Figure 7.

Figure 7: Photograph of Exemplary ZTE Accused Product (MAX XL (Model No. N9650))



(Compl., Ex. 128.).

D. INVT's Domestic Industry Products

INVT's economic domestic industry is based on the domestic activities and investments related to certain domestic industry products such as the Samsung Galaxy smartphones and

Public Version

tablets (“DI Products”) of INVT’s licensee, Samsung Electronics America (“Samsung”).¹⁶ Mr. Timothy Sheppard, Samsung’s Vice President of Supply Chain and Logistics, testified that: (1) [REDACTED] Samsung are devoted to the technical aspects of Samsung’s mobile devices in the U.S.; and (2) Samsung’s investments in Galaxy products in the U.S. As discussed in the economic prong of the domestic industry, Section IX below, Samsung has invested [REDACTED] [REDACTED] in domestic activities that support its Galaxy products. (See CDX-0007C.0002-3; CX-0187C; CX-0188C; CX-0191C; CX-0192C; CX-0196C; Tr. (Sheppard) at 1363:17-1364:15, 1370:8-1371:6, 1373:13-1376:8; Tr. (Joshua Lathrop)¹⁷ at 1763:5-1765:5, 1766:5-1782:20.).

¹⁶ The Commission has held that “the domestic industry inquiry under Section 337 is not limited to the activities of the patent holder, but also involved the activities of any licensees.” *Certain Variable Speed Wind Turbines and Components Thereof*, Inv. No. 337-TA-376, USITC Pub. 3072, Comm’n Op. on Remand at 7 (Nov. 1997) (internal citations omitted); *Certain Prods. Having Laminated Packaging and Components Thereof*, Inv. No. 337-TA-874, Comm’n Op. at 15 (Sept. 3, 2013) (“a licensor may rely upon a licensee’s domestic activities and investments”) (other citations omitted). Moreover, Commission decisions have held that the economic prong of the domestic industry requirement can “be established where a complainant bases its claim exclusively on the activities of a contractor/licensee.” *Certain Male Prophylactic Devices*, Inv. No. 337-TA-546, Order No. 22 at 7 (Mar. 15, 2006) (citing *Certain Methods of Making Carbonated Candy Prods.*, Inv. No. 337-TA-992, ID at 142 (Dec. 8, 1989) (unreviewed in-relevant-part) (finding that existence of a domestic industry based on a long-term, domestic production of candy by a contractor/licensee using the patented process); *Certain Silicon-on-Insulator Wafers*, Inv. No. 337-TA-1025, ID at 16 (Feb. 8, 2017) (unreviewed) (finding that economic domestic industry found where a non-practicing entity relied solely upon the investments of its licensee); see also Commission Rule 210.12; 19 C.F.R. § 210.12(a)(7). Rule 210.12(a)(9)(iii)-(iv) requires “an identification of each licensee under each involved U.S. patent” as well as “a copy of each license agreement(if any) for each involved U.S. patent that Complainant relies upon . . . to support its contention that a domestic industry as defined in section 337(a)(3) exists or is in the process of being established as a result of the domestic activities of one or more licensees.” 19 C.F.R. § 210.12(a)(9)(iii)-(iv). The non-exclusive patent license and settlement agreement (“Samsung License”) between INVT and Samsung Electronics Co. Ltd. (“SEC”) is dated January 15, 2018 and is attached as Confidential Exhibit 134 to the Complaint. (See also CX-0460C; JX-0016C.). SEA is a licensed affiliate of SEC. (CX-0184C.0001; CX-0460C.0006.).

¹⁷ When he testified during the Hearing on September 19, 2019, Mr. Joshua Lathrop was the Director of Berkeley Research Group, LLC. (CPSt. at Ex. D.). Complainant identified Mr. Lathrop as an expert to testify about the economic and financial analysis of Complainant’s domestic industry, and to rebut the testimony of Respondents’ expert and/or fact witnesses. (*Id.* at 7.).

Public Version

“Respondents and INVT stipulate that for purposes relevant to the Asserted Patents any finding by the ALJ regarding domestic industry—technical prong of the Representative Product Samsung Galaxy S9 shall apply to the following Domestic Industry Products: Galaxy S8 SM-G950U; Galaxy S8 SM-G950X; Galaxy S8 Active SM-G892A; Galaxy S8 Active SM-G892U; Galaxy S8 Plus SM-G955U; Galaxy S8 Plus SM-G955X; Galaxy Note8 SM-N950U; Galaxy Note8 SMN950X; Galaxy S9 SM-G960X; Galaxy S9 Plus SM-G965U; Galaxy S9 Plus SM-G965X; Galaxy Note9 SM-N960U; Galaxy Note9 SM-N960X.” (Representative Product Stipulation ¶ 6.). An exemplary DI Product is shown below in Figure 8.

Figure 8: Photograph of Exemplary DI Product (Samsung Galaxy S9 (Model No. SM-G960U))



(Compl., Ex. 132.).

VI. PERSON OF ORDINARY SKILL IN THE ART¹⁸

The *Markman* Order adopted this definition for a “person of ordinary skill in the art,” as proposed by INVT and Staff. Respondents did not oppose the proposed definition:

a person skilled in the art would at least have both a bachelor’s degree in Electrical Engineering or an equivalent field and three years of experience in wireless

¹⁸ The legal standard for the level of a person of ordinary skill in the art can be found in the *Markman* Order. (See *Markman* Order at 19-20.). None of the definitions proposed were dispositive of any issue.

communications or an MSc degree in Electrical Engineering or an equivalent field and one year of experience in wireless communications.

(*Markman* Order at 8-9 (“INVT proposed a definition for a person of ordinary skill in the art. ... Staff agreed with the definition. Respondents did not offer a definition ... Finding no opposition from Respondents, this Order adopts INVT and Staff’s definition[.]”).).

VII. U.S. PATENT NOS. 7,206,587 & 6,760,590

A. INVT Failed to Prove That Claim 4 of the ’587 Patent and Claims 3 and 4 of the ’590 Patent Are Essential to the 3G and LTE Standards

Whether the Asserted Patents are standard essential or SEPs, turns on whether claims 3 and 4 of the ’590 patent and claim 4 of the ’587 patent read on the 3G and LTE standards, as INVT asserted and argued, albeit unsuccessfully given the evidence. (CBr. at 48-60.). As discussed below, these claims are not standard essential because their “encodes the information” limitations fail to read on the 3G and LTE encoding standards. Staff concurred. (SBr. at 28-41.).

1. Legal Standard of “Essentiality” for Standard Essential Patents

Under the ETSI¹⁹ IPR²⁰ Policy, dated October 8, 2018, “essential” means that it is:

not possible on technical (but not commercial) grounds, taking into account normal technical practice and the state of the art generally available at the time of standardization to make, sell, lease, otherwise dispose of, repair, use or operate EQUIPMENT or METHODS which comply with a STANDARD without infringing that IPR.

(CX-0280.0043.).

Where an accused product complies with a given standard, a patent owner can prove infringement by showing that the asserted patent claims read on required portions of the standard, such that implementing the standard necessarily meets the elements of the claim. *See*,

¹⁹ “ETSI [is] the European Telecommunications Standards Institute, which began at the GSM 2G standard, and eventually started working on the 3G standard, which was then taken up by an international committee called 3GPP.” (Tr. (Nettleton) at 506:5-9.). .

²⁰ IPR stands for “Intellectual Property Rights.” (CX-0280.0005.).

e.g., Optis Wireless Tech., LLC v. Huawei Tech. Co., Ltd., 2018 U.S. Dist. LEXIS 115100, at *4 (E.D. Tex. July 11, 2018) (infringement may be shown by showing that: “(1) the standard necessarily meets the elements of the claim, (2) the accused product complies with the standard, and therefore (3) the accused product meets the claim”).

1. Essentiality Analysis

Claims 3 and 4 of the '590 patent require “a coder that encodes the information such that the upper digit is assigned a larger number of bits than the lower digit.” (JX-0001 ('590 Patent), cls. 3-4.). Likewise, claim 4 of the '587 patent requires “the coding device encodes the information such that the most significant bit of the plurality of bits is less susceptible to errors in a propagation path than other bits of the plurality of bits.” (JX-0002 ('587 Patent), cl. 4.).

The *Markman* Order treated the “encodes the information” language in claim 4 of the '587 patent as a means-plus-function term²¹ that is limited to the disclosed structure, specifically “element 1101 of Fig. 15, as discussed in column 20, line 28 to column 21, line 10, in the context of disclosed Embodiment 6, and equivalents thereof.” (*Markman* Order at 22-23.).²² That was because the “encodes the information” language in claim 4 of the '587 patent lacked “structural mooring with respect to how the encoding takes place ‘such that the most significant bit of the plurality of bits is less susceptible to errors in a propagation path than other bits of the plurality of bits.’” (*Id.* at 25.). Moreover, the term “less susceptible to errors in a propagation path” was found in the *Markman* Order to be “open-ended and relative, not tied to structure.” (*Id.*).

²¹ “An element in a claim for a combination may be expressed as a means or step for performing a specified function without the recital of structure, material, or acts in support thereof, and such claim shall be construed to cover the corresponding structure, material, or acts described in the specification and equivalents thereof.” 35 U.S.C. § 112 ¶ 6.

²² The *Markman* Order found that Respondents did not prove by clear and convincing evidence that the “encodes the information” language in claim 4 of the '587 patent is indefinite. (*Id.* at 22-23.).

Public Version

INVT attempted to distinguish the “encodes the information” limitations of the asserted claims of the ’587 and ’590 patents. INVT asserted and argued that “[a]s compared to the ’590 Patent, which only requires more bits of the code word be ‘assigned’ to an ‘upper digit,’” the ’587 Patent “requires unequal error protection, such that the MSB is better protected than other bits.” (CBr. at 40.). According to INVT, “evidence presented at the hearing establishes that both the 3G and LTE standard render the MSB less susceptible to errors.” (*Id.* at 41 (citing CX-0470-0002)).

INVT is mistaken. The *Markman* Order linked the respective “encodes the information” limitations to Embodiment 6 disclosed in the shared specification of the ’587 and ’590 patents, shown below in Figure 9. For the ’587 patent, the *Markman* Order confined the open-ended, structure-deficient “encodes the information” limitation to the structure disclosed in Embodiment 6, and equivalents thereof. (*Markman* Order at 24.).

For the ’590 patent, the *Markman* Order observed that Embodiment 6 “sounds much like” what the “encodes the information” limitation requires because, in that limitation, “the upper digit is assigned a larger number of bits than the lower digit.” (*Id.* at 25-26.). Thus, what Embodiment 6 of the shared specification discloses in terms of an encoding technique is highly relevant to, if not largely dispositive of, the prevailing issue here: that is, whether CGI encoding techniques required by the 3G and LTE standards necessarily satisfy the separate but similar-in-scope “encodes the information” limitations found in the ’587 and ’590 patents.

Figure 9: Figure 15 of the '587 and '590 Patents Depicting Embodiment 6

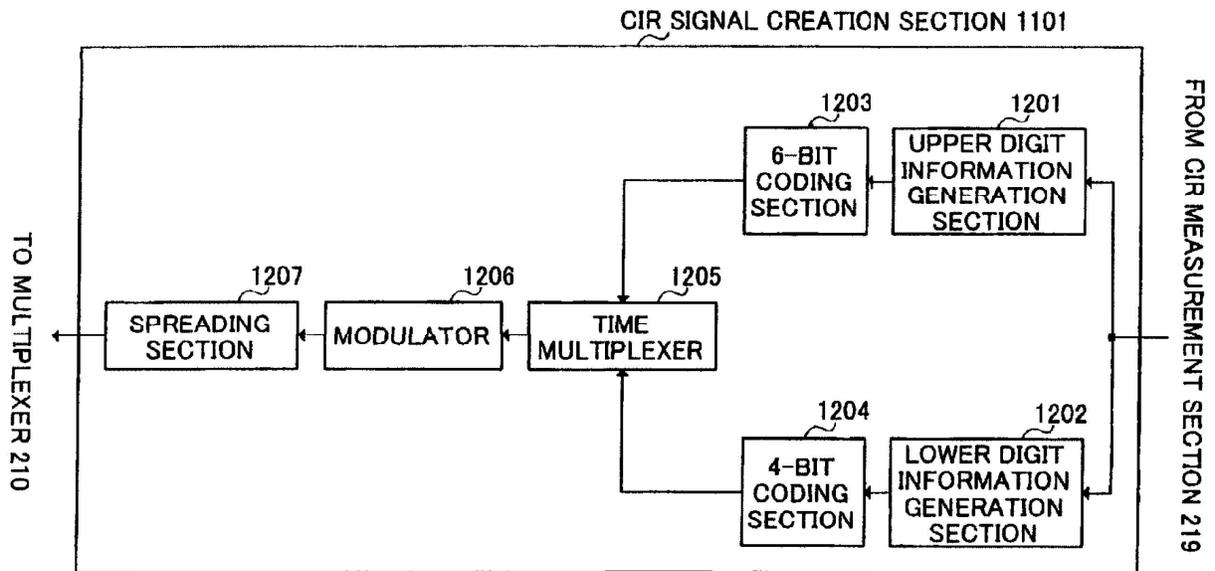

(JX-0001 ('590 Patent) at Fig. 15; JX-0002 ('587 Patent) at Fig. 15).

What the shared specification teaches about Embodiment 6 is very instructive:

In the 6-bit coding section 1203, the value of the upper digit in the CIR value (here, “8”) is converted to a 6-bit code word, and the value of the lower digit in the CIR value (here, “7”) is converted to a 4-bit code word.

As the number of different code words that can be represented by 6 bits is 2^6 , and the number of different code words that can be represented by 4 bits is 2^4 , the code word minimum distance between code words can be made larger for code words represented by 6 bits. Therefore, a code word represented by 6 bits is less susceptible to being mistaken for another code word than a code word represented by 4 bits. That is to say, in this embodiment, the value of the upper digit of a CIR value is less susceptible to errors.

(JX-0001 ('590 Patent) at 21:7-20.).

In other words, given that each upper or lower digit is drawn from a range of only ten (10) numbers (0 → 9), encoding the upper digit with six bits and mapping each of the ten (10) possible upper digit numbers to one of sixty-four (64) possible code words allows the space between code words, and thus error protection, to be greater for the upper digit than for the lower

digit, where each of the ten (10) possible numbers is mapped to one of only sixteen (16) possible code words. (*See id.*)

The shared specification of the '587 and '590 patents provides flexibility in terms of the number of bits used to encode each digit, so long as more bits are used to encode the upper digit relative to the lower digit. (*Id.* at 21:38-41 (“as long as the number of bits of the code word corresponding to the upper digit value is greater than the number of bits of the code word corresponding to the lower digit value, there are no particular limitations on these numbers of bits.”).)

Figure 10: INVT’s Depiction of Embodiment 6 of the '587 and '590 Patents

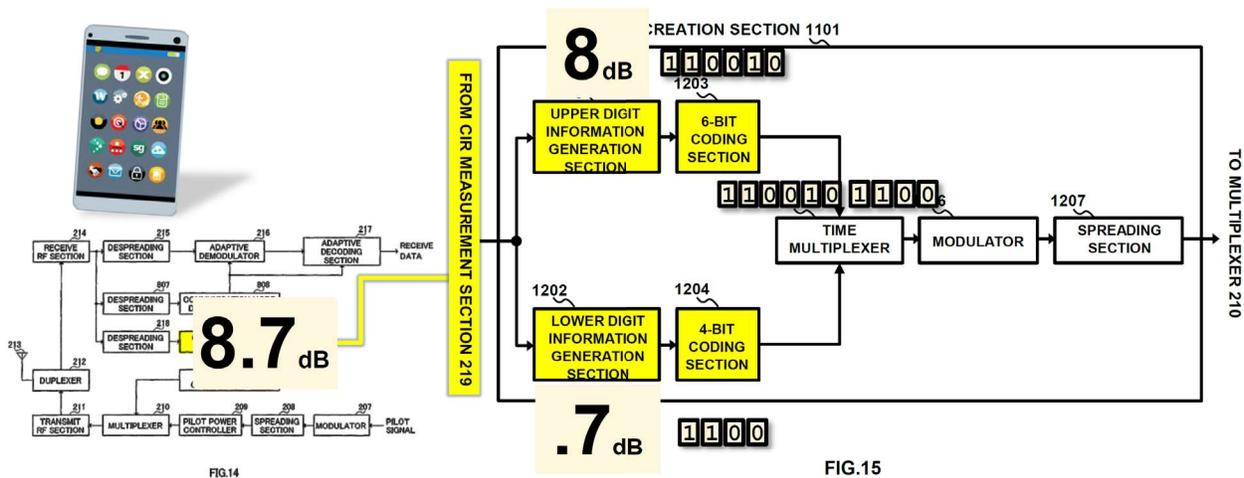

(CDX-0003C.0015 (introduced during the testimony of Dr. Wicker).)

As depicted in Figure 10 above, what the shared specification of the '587 and '590 patents teaches, in a nutshell, is separate encoding mathematics for an upper CGI digit, on the one hand, and a lower CGI digit, on the other hand. What the specification does not teach is that *individual bits* contained in an encoding (e.g., 1100101100) of a CGI value (e.g., 8.7) represent a mathematical blending of information provided by upper digit (e.g., 8) and lower digit (e.g., 7) of the initial CQI value. Instead, the opposite is true, insofar as “110010”

Public Version

represents only the “8” and “1100” represents only the 7 in the example provided above. This was confirmed by INVT’s expert, Dr. Nettleton:

Q. Okay. You would agree with me there is no disclosure in the ’590 or ’587 Patents, whatsoever, where the information of the upper digit could be assigned to bits that represent the lower digit, correct?

A. I don’t recall anything of that kind.

(Tr. (Nettleton) at 687:4-20 (citing and playing video clip of Tr. (Nettleton Dep.) at 171:15-258).).

In other words, in an encoding of a CGI value (e.g., 8.7), one set of bits is “assigned” to the upper digit and a distinct set of bits is assigned to the lower digit. (*See* JX-0001 (’590 Patent) at 21:7-20, Fig. 15.). There is no overlap between the bits assigned to the upper digit and the bits assigned to the lower digit. (*See id.*). INVT cites no evidence to the contrary from the intrinsic or extrinsic record.

Another way of saying this is that Figure 15 and corresponding Embodiment 6 teach mathematical sequestration of an MSB, on the one hand, and remaining bits, on the other hand, for the purposes of encoding. (*Id.* at 19:34-21:42.). For example, in Figure 10 above, upper digit “8” (or its binary form, 1000) is encoded into a six-bit codeword without any information pertaining to lower digit “7” (or its binary form, 0111). (*See id.*). Likewise, lower digit “7” is encoded into a four-bit codeword without any information pertaining to upper digit “8.” (*See id.*). The code words corresponding to the upper and lower digits are then concatenated, not blended. (*Id.* at 20:55-62 (“The time multiplexer 1205, by storing the 6-bit code word in the first half of a slot and storing the 4-bit code word in the following latter half of the slot, performs time multiplexing of the code word for the integer part of the CIR value (that is, the code word corresponding to the value of the upper digit) and the code word for the fractional part of the CIR

Public Version

value (that is, the code word corresponding to the value of the lower digit).”).

None of the information pertaining to lower digit “7” gets incorporated into the six-bit encoding, “110010.” Likewise, none of the information pertaining to upper digit “8” gets incorporated into the four-bit encoding, “110010.” The separate mathematics condition holds. That said, Respondents are mistaken that the ’590 and ’587 patents teach “using two separate coding paths to achieve its unequal error protection.” (RRBr. at 9; Tr. (Wicker) at 1525:4-1527:17 (3G and LTE standards require a single encoding operation not separate encoding operations).).

Building upon the exemplary embodiment of Figure 15, INVT demonstrated that, mathematically speaking, using two matrices (e.g., 6 x 4 for the upper digit and 4 x 4 for the lower digit, as shown below in Figure 11) yields the same result as using a single, special “block diagonal” matrix, also shown below in Figure 11. (CBr. at 66.). Respondents’ technical expert, Dr. Wicker, appeared to agree. (Tr. (Wicker) at 1612:12-1613:15 (“Q. And that would just mean, as I’m showing here in slide 37, you put the 6 X 4 in the upper left, 4 X 4 in the lower right, and you could use one coding matrix to do the whole process, right? A. Yes, you could.... You’d have to change the structure.... In other words, it’s not done the same way [as in the ’578/’590 patents]. But the result would be the same.”).).

Respondents’ argument that the asserted claims require “two coding paths” or “two separate coding sections” amounts to limiting the asserted claims to a single disclosed embodiment, which is disfavored. (RRBr. at 25 (emphasis in original); *Teleflex, Inc. v. Ficosa N. Am. Corp.*, 299 F.3d 1313, 1327 (Fed. Cir. 2002) (“[e]ven when the specification describes only a single embodiment, the claims of the patent will not be read restrictively unless the patentee has demonstrated a clear intention to limit the claim scope using ‘words or expressions

of manifest exclusion or restriction.”). Respondents’ argument also constitutes a conflation of two things conveyed by Figure 15 of the ’587/’590 patents: the required “separate math” concept and the optional separate-path, separate-calculation approach for implementing that concept.

Figure 11: INVT’s Depiction of Two Ways to Practice Embodiment 6, With (upper diagram) and Without (lower diagram) Using Two Separate Coding Paths

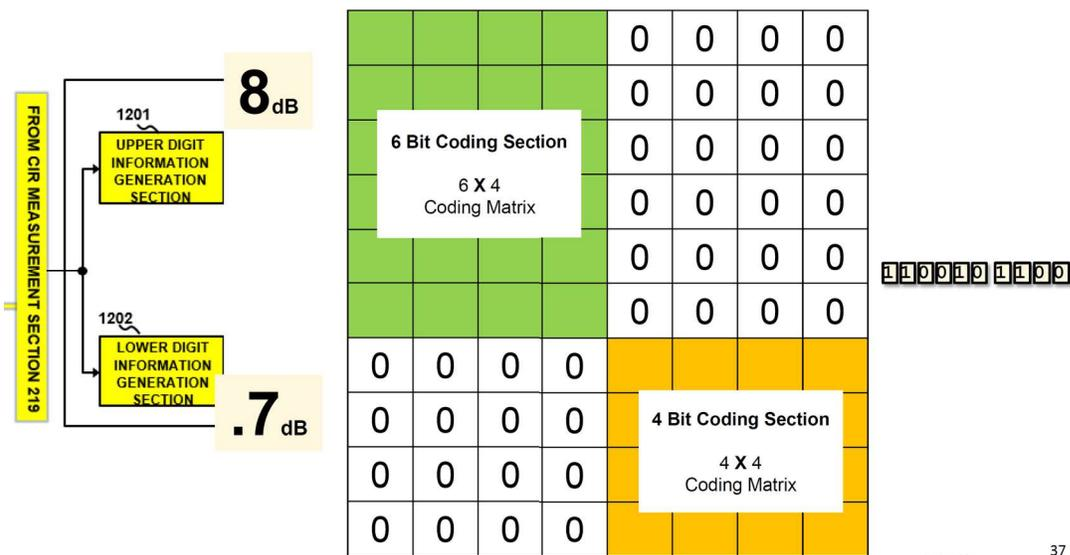
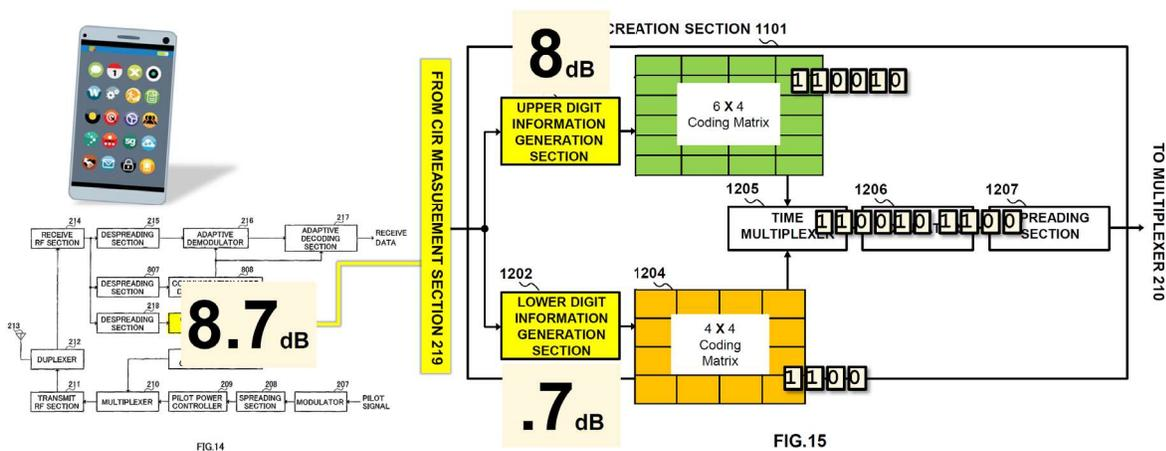

(CDX-0008C at 36-37 (introduced during the cross examination of Dr. Wicker).).

In sum, based on the explanations and testimony, the asserted claims of the ’590 and ’587

Public Version

patents do not require encoding of CGI bits by separate paths or calculations, as Respondents argued. This is because Figure 11 demonstrates that the “separate math” encoding condition of the ’587/’590 patents can be satisfied by the use of: (i) two encoding matrices (one for the MSB and one for the less significant bits) and two separate encoding paths (upper diagram); or, alternately, (ii) one, special “block diagonal” matrix and one encoding path (lower diagram).²³ Comparing these two (2) alternatives, the encoding math is nearly identical, and the outcome is the same, as Dr. Wicker acknowledged. (Tr. (Wicker) at 1612:12-1613:15.).

Nothing in the ’587/’590 patents’ shared specification expressly forecloses the second embodiment, and the patentee has not demonstrated a clear intention to limit the scope of the asserted claims to the first embodiment using the “words or expressions of manifest exclusion or restriction” required by *Teleflex*.

However, the ’590 and ’587 patents *do not* teach or cover all single-path or single-calculation encoding techniques. For example, the ’590 and ’587 patents do not teach that *individual bits* contained in a CGI encoding can represent a mathematical blending of information provided by both the most significant digit, on the one hand, and less significant digits of the initial CQI value, on the other hand. Instead, the math must be separate. Staff summarized this concept eloquently: “information of the upper digit is assigned to codeword bits that are separate and distinct from the codeword bits which are assigned to the information of the lower digit (that is, assignment in the patents always occurs such that the information of the upper digit is not assigned to any codeword bits that are assigned to the lower digit).” (SBr. at 32-33.).

²³ Staff did not explicitly address this latter “diagonal matrix” issue.

Against this backdrop, it is clear that the CGI encoding of the 3G and LTE standards function in a fundamentally different way from the CGI encoding of the asserted claims.

It is immediately apparent from Figures 12 (3G) and 13 (LTE) below that the 3G and LTE standards do not use “block diagonal” matrices to encode CGI values. Consequently, it is significant that both experts agreed that the MSB and the less significant bits of a CGI value are used in a blended fashion to calculate one or more bits of the resulting CGI encoding. (Tr. (Nettleton) at 747:8-748:12 (explaining that the least significant bit “is involved” in the mathematical operations for each bit); Tr. (Wicker) at 1480:4-1481:3 (“all the bits are encoded into the same 20-bit codeword”).). As Dr. Wicker explained, no CGI bit is singled out and “assigned more code word bits than another.” (Tr. (Wicker) at 1472:9-18; *see also id.* at 1480:23-1481:9; RDX-0005C.0037.).

Figure 12: Respondents’ Depiction of How CGI Values are Encoded Pursuant to the 3G Standard

Accused 3G Encoding Scheme

Table 14: Basis sequences for (20,5) code

i	M _{i,0}	M _{i,1}	M _{i,2}	M _{i,3}	M _{i,4}
0	1	0	0	0	1
1	0	1	0	0	1
2	1	1	0	0	1
3	0	0	1	0	1
4	1	0	1	0	1
5	0	1	1	0	1
6	1	1	1	0	1
7	0	0	0	1	1
8	1	0	0	1	1
9	0	1	0	1	1
10	1	1	0	1	1
11	0	0	1	1	1
12	1	0	1	1	1
13	0	1	1	1	1
14	1	1	1	1	1
15	0	0	0	0	1
16	0	0	0	0	1
17	0	0	0	0	1
18	0	0	0	0	1
19	0	0	0	0	1

$$b_i = \sum_{n=0}^4 (a_n \times M_{i,n}) \text{ mod } 2$$

where $i = 0, \dots, 19$.

The channel quality information bits are a_0, a_1, a_2, a_3, a_4 (where a_0 is LSB and a_4 is MSB).

RX-1607.68 (TS 25.212 v5.1.0 § 4.7.1.2)

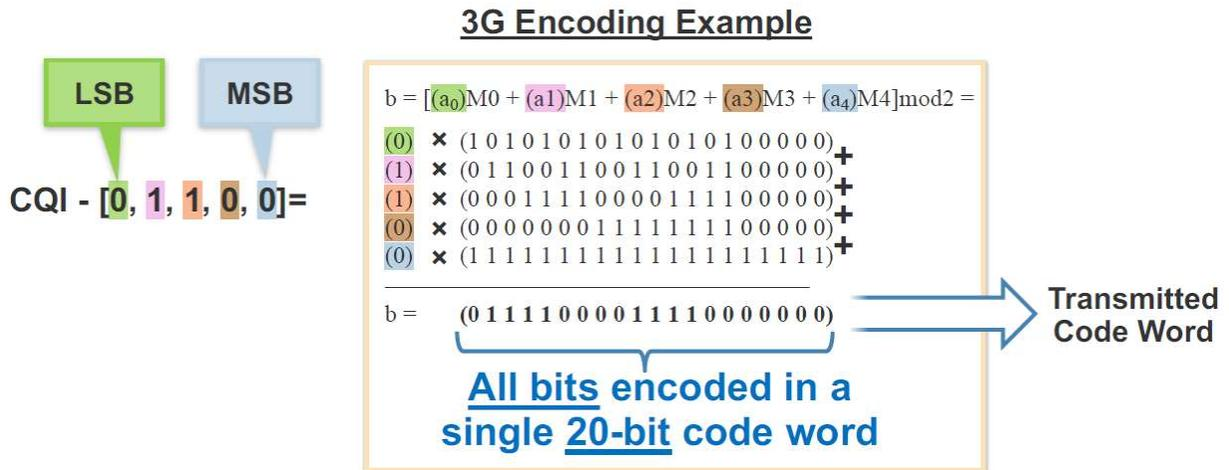

(RDX-0005C at 52, 54 (introduced during the cross examination of Dr. Wicker).).

The LTE standard, for instance, takes an initial CQI value of four (4) bits and “maps it to a 20-bit code word.” (*Id.*). As shown below in Figure 13, in the LTE standard encoding operation, each CQI “bit is multiplied by its associated column,” which is a full “20 [coefficients].” (Tr. (Wicker) at 1478:1-1479:11, 1476:16-1477:17; RDX-0005C.0036; Tr. (Nettleton) at 693:2-10.). The multiplication of each CQI bit by each column (or basis sequence) produces “intermediate values.” (RDX-0005C.0036; Tr. (Wicker) at 1478:1-1479:11.). The first bit of the output code word *b* is calculated by adding the intermediate values (0 + 1 + 0 + 0), which were created by multiplying each CQI bit by a coefficient in the matrix, and performing a modulo 2 operation on the sum. (Tr. (Wicker) at 1479:12-21; RDX-0005C.0036; Tr. (Nettleton) at 701:4-8.).

Accordingly, the first bit of the output code word *b* is calculated using each of the CQI bits in a mathematical calculation or, stated another way, by blending information from most and less significant bits using math. (*Id.*).

Figure 13: Respondents' Depiction of How CGI Values are Encoded Pursuant to the LTE Standard

**Alleged Upper Digit
20-Bit Basis Sequence**

**Alleged Lower Digit
20-Bit Basis Sequence**

CQI = [a₁ a₂ a₃ a₄]

Table 5.2.3.3-1 Basis sequences for (20, A) code

i	M ₁₀	M ₁₁	M ₁₂	M ₁₃	M ₁₄	M ₁₅	M ₁₆	M ₁₇	M ₁₈	M ₁₉	M ₂₀	M ₂₁	M ₂₂
0	1	1	0	0	0	0	0	0	0	0	1	1	0
1	1	1	1	0	0	0	0	0	0	1	1	1	0
2	1	0	0	1	0	0	1	0	1	1	1	1	1
3	1	0	1	1	0	0	0	0	1	0	1	1	1
4	1	1	1	1	0	0	0	1	0	0	1	1	1
5	1	1	0	0	1	0	1	1	1	0	1	1	1
6	1	0	1	0	1	0	1	0	1	1	1	1	1
7	1	0	0	1	1	0	0	1	1	0	1	1	1
8	1	1	0	1	1	0	0	1	0	1	1	1	1
9	1	0	1	1	1	0	1	0	0	1	1	1	1
10	1	0	1	0	0	1	1	1	0	1	1	1	1
11	1	1	1	0	0	1	1	0	1	0	1	1	1
12	1	0	0	1	0	1	0	1	1	1	1	1	1
13	1	1	0	1	0	1	0	1	0	1	1	1	1
14	1	0	0	0	1	1	0	1	0	0	1	0	1
15	1	1	0	0	1	1	1	1	0	1	1	0	1
16	1	1	1	0	1	1	1	0	0	1	0	1	1
17	1	0	0	1	1	1	0	0	1	0	0	1	1
18	1	1	0	1	1	1	1	1	0	0	0	0	0
19	1	0	0	0	0	1	1	0	0	0	0	0	0

$$b_i = \sum_{n=0}^{A-1} (a_n \cdot M_{i,n}) \text{ mod } 2 \text{ where } i = 0, 1, 2, \dots, B-1.$$

RX-1517.32

RX-1517.32

LTE Encoding Example

$$b = [(a_0)M_0 + (a_1)M_1 + (a_2)M_2 + (a_3)M_3] \text{ mod } 2 =$$

CQI = 6
 [0 1 1 0]
 a₀ a₁ a₂ a₃

(0) X	(1 1 1 1 1 1 1 1 1 1 1 1 1 1 1 1 1 1 1 1)	=	00000000000000000000	+
(1) X	(1 1 0 0 1 1 0 0 1 0 0 1 0 1 0 1 1 0 1 0)	=	11001100100101011010	+
(1) X	(0 1 0 1 1 1 0 1 0 0 1 1 1 0 0 0 0 1 0 0 0)	=	01011010011100001000	+
(0) X	(0 0 1 1 1 0 0 1 1 1 0 0 1 1 0 0 0 1 1 0)	=	00000000000000000000	+

b = (10010110111001010010)

All bits encoded in a single 20-bit code word

(RDX-0005C at 35-36 (introduced during the cross examination of Dr. Wicker).).

Finally, contrary to INVT's position, Dr. Wicker's explanation with respect to why the 3G and LTE standards do not have a coding structure that is equivalent to the structure disclosed

Public Version

in element 1101 of Figure 15 of the '587/'590 patents is compelling.²⁴ (Tr. (Wicker) at 1525:23-1527:17.). By contrast, Dr. Nettleton's opinion on this issue is absent. (SBr. at 40 ("Dr. Nettleton did not opine on whether the standard requires a structure that is equivalent under 35 U.S.C. § 112, para. 6, and as such, was precluded from offering an opinion regarding equivalent structure. In light of the foregoing, Complainant has not met its burden of showing that asserted claim 4 of the '587 Patent is essential to the asserted standards, as the standards do not show—much less require—the claimed encoding structure for the reasons presented above.")).

"Infringement under the doctrine of equivalents may be found when the accused device contains an 'insubstantial' change from the claimed invention.... Whether equivalency exists may be determined based on ... the 'triple identity' test, namely, whether the element of the accused device 'performs substantially the same function in substantially the same way to obtain the same result.'" *TIP Sys., LLC v. Phillips & Brooks/Gladwin, Inc.*, 529 F.3d 1364, 1376-77 (Fed. Cir. 2008) (citations omitted).

The essential inquiry here is whether "the accused product or process contain elements identical or equivalent to each claimed element of the patented invention[.]" (*Id.*). They do not here because of the markedly different way in which the 3G and LTE standards encode CGI information as compared to element 1101 of Figure 15 of the '587/'590 patents.²⁵

Same Function. As compared to the error protection scheme that the '587 and '590

²⁴ The *Markman* Order treated the "encodes the information" language in claim 4 of the '587 patent as a means-plus-function term that is limited to the disclosed structure, specifically "element 1101 of Fig. 15, as discussed in column 20, line 28 to column 21, line 10, in the context of disclosed Embodiment 6, and equivalents thereof." (*Markman* Order at 22-23 (emphasis added)).

²⁵ This remains true even if, as INVT argued, the structure of Figure 15 corresponding to the means-plus-function language of claim 4 of the '587 patent is limited to "coding sections 1203 and 1204 as described at col. 20, ll. 42-50, and col. 21, ll. 30-37." (CBr. at 48.).

Public Version

patents teach, the 3G and LTE standards perform substantially the same function. Both the approach taught by the '587 and '590 patents, on the one hand, and the 3G and LTE standards, on the other hand, perform the function of “encoding the information to obtain a code word” where “the information ... is generated in association with ... downlink channel quality.” (See JX-0002 ('587 patent), cl. 4.).

Same Result. Also, as discussed above, the weight of the evidence supports a finding that the approach that the '587 and '590 patents teach, and the approaches that the 3G and LTE standards require, obtain the same result. That is, the '587 and '590 patents and the 3G and LTE standards both provide more error protection to certain bits of a CGI value (i.e., MSB) as compared to other bits (i.e., LSB) of that CGI value (e.g., with respect to a value of 8.7, all of the above provide more protection for bits associated with 8 (the MSB) than for bits associated with 7, the LSB).

Different Way. However, what distinguishes the 3G and LTE standards from the '587 and '590 patents is that the former encode CGI values in a very different way as compared to the technique taught in the '587 and '590 patents. As Dr. Wicker explained, supported by the evidence, the accused 3G and LTE standards do not perform separate and distinct encodings of bits or subsets of bits within a CGI value. (Tr. (Wicker) at 1525:23-1526:7; RDX-0005C.0063-65.). As Dr. Wicker explained, the 3G and LTE standards cannot use different code word lengths to provide more error protection (more code word minimum distance, for example) for one subset of bits vis-à-vis another subset of bits within a CGI value, as was done for the upper and lower digits shown in Figure 15 of the '587 and '590 patents. (*Id.*).

In the 3G and LTE standards, the information corresponding to the “upper digit” or MSB is not reflected exclusively in code word bits that are separate and distinct from the code word

Public Version

bits corresponding to the information from less significant bits. Instead, the 3G and LTE standards encode all the bits of a CGI value in a blended fashion within a single 20-bit code word.²⁶ (Tr. (Wicker) at 1525:23-1526:7; RDX-0005C.0063.). Consequently, as Dr. Wicker persuasively explained, all code words in the 3G and LTE standards have the same code word minimum distance. (Tr. (Wicker) at 1484:19-1500:23, 505:12-1516:23; RX-1766.0255; RDX-0005C.0040.). By contrast, the '587 and '590 patents describe disparate codeword minimum distances such that more distance (and thus error protection) is provided to encodings of an upper digit versus a lower digit within a CGI value. (JX-0001 ('590 Patent) at 21:7-20.) (“As the number of different code words that can be represented by 6 bits is 2^6 , and the number of different code words that can be represented by 4 bits is 2^4 , the code word minimum distance between code words can be made larger for code words represented by 6 bits.”). Disparate codeword minimum distances provided to encodings of an upper versus lower digit within a CGI value are antithetical to the 3G and LTE standards.

Dr. Wicker’s analysis is corroborated by his own textbook, “Error control systems for digital communication and storage,” which teaches that linear block codes (like the accused codes in the 3G and LTE standards) all have the same codeword minimum distance. (RX-

²⁶ During the Hearing, Dr. Nettleton attempted to manufacture an infringement argument by referring to the numbers in the 3G and LTE encoding matrices as “coefficients” and not “bits.” (Tr. (Nettleton) at 565:1-16 (“Well, if you look back at that funny-looking formula, it’s pretty obvious that these are not bits. That’s confusing, because they take on the values 0 and 1. But what they are in fact is coefficients, because the output of that sigma-shaped thing, the output of that summation can range from 0 to 5, and that’s clearly not a binary number. So these are coefficients, not bits.”).). This argument is a red herring. Whether called coefficients, bits, entries, or numbers, all of which appear to be apt descriptions of the contents of the 3G and LTE encoding matrices, the configuration of those coefficients, bits, entries, or numbers is such that they are not arranged in a special, diagonal matrix and, consequently, the MSB and less significant bits of a CGI value are used in a blended fashion to calculate one or more bits of the resulting CGI encoding. (Tr. (Nettleton) at 747:8-748:12; Tr. (Wicker) at 1480:4-1481:3.). In other words, the separate mathematical condition explained herein is not satisfied.

1766.0255; Tr. (Wicker) at 1484:14-1485:13; RDX-0005C.0040.). Dr. Wicker’s opinions on this issue are unrebutted because Dr. Nettleton did not analyze infringement of claim 4 of the ’587 patent under the *Markman* constructions for that claim. (Tr. (Nettleton) at 503:7-637:1.).

For the reasons stated above, INVT has failed to prove that claims 3 and 4 of the ’590 patent and claim 4 of the ’587 patent are essential to the 3G and LTE standards. Moreover, because Dr. Nettleton did not provide an analysis of the infringement of claim 4 of the ’590 patent, INVT has waived argument on this issue under Ground Rule 10.1.

B. INVT Failed to Prove That the Accused Products Satisfy Claims 3 and 4 of the ’590 patent and Claim 4 of the ’587 Patent

1. Infringement Overview

INVT accused Apple, HTC, and ZTE of directly infringing claims 3 and 4 of the ’590 patent and claim 4 of the ’587 patent, the limitations of which are listed below in Table Nos. 7 and 8.²⁷ (CBr. at 11.). Respondents and Staff dispute this accusation. (RRBr. at 8-32; SBr. at 41-42.). For the reasons set forth below, INVT has failed to prove by a preponderance of the evidence that the Accused Products satisfy these claims.

Table No. 7: Limitations of Claims 3 and 4 of the ’590 Patent (with disputed limitations underlined)

Claim 3	
3[pre]	A communication terminal apparatus comprising:
3[a]	<u>a measurer that measures a downlink channel quality and outputs information that is generated in association with said downlink channel quality and composed of a plurality of digits including an upper digit and an [sic] lower digit;</u>
3[b]	a coder that encodes the information <u>such that the upper digit is assigned a larger number of bits than the lower digit;</u> and

²⁷ INVT did not assert or argue that the Respondents infringed indirectly or under the Doctrine of Equivalents. Therefore, INVT waived argument on this issue under Ground Rules 7.2 and 10.1.

Public Version

Claim 3	
3[c]	a transmitter that transmits the encoded information to a base station apparatus.
Claim 4	
4	The communication terminal apparatus according to claim 3, wherein the upper digit contains a most significant bit of the information.

(JX-0001 ('590 Patent), cls. 3-4.).

Table No. 8: Limitations of Claim 4 of the '587 Patent (with disputed limitations underlined)

Claim 4	
4[pre]	A communication terminal apparatus comprising:
4[a]	<u>a measuring device that measures reception quality of a pilot signal to output information having a plurality of bits that indicate the measured reception quality;</u>
4[b]	a coding device that encodes the information to obtain a code word; and
4[c]	a transmitter that transmits the code word, wherein:
4[d]	the coding device encodes the information <u>such that the most significant bit of the plurality of bits is less susceptible to errors in a propagation path than other bits of the plurality of bits.</u>

(JX-0002 ('587 Patent), cl. 4.).

As an initial matter, Respondents disputed whether the Accused Products satisfy only two (2) elements of claims 3 and 4 of the '590 patent and claim 4 of the '587 patent.²⁸ The first and most important dispute is whether the Accused Products satisfy the “encodes the information” limitations. (CBr. at 40 (“the key dispute regarding infringement ... is whether the matrices used

²⁸ As a result, Respondents waived argument with respect to any other limitations recited in these claims under Ground Rule 10.1. Specifically, Respondents waived argument on the preamble and the transmitter limitation of claim 3 of the '590 patent, the MSB upper digit limitation added by claim 4 of the '590 patent, and the preamble, coding device, and transmitter limitations of the '587 patents.

by the 3G and/or LTE standards for encoding channel quality information meet the ‘assigned’ claim limitation”) (addressing ’590 patent); *see also id.* at 41 (“[t]he key dispute as to infringement ... is whether the ‘coding device’ claim element, as construed by the ALJ, is satisfied by the 3G and/or LTE CQI encoding schemes”) (addressing ’587 patent).).

That dispute was resolved above in Respondents’ favor. That is because Respondents conceded that their products “encode[] the information” as set forth in the 3G and LTE standards. (Tr. (Respondents’ Opening) at 29:22-25; Tr. (Wicker) at 1520:3-12.). As explained above, INVT has failed to prove by a preponderance of the evidence that the LTE and 3G standards practiced by the Accused Products satisfy the “encodes the information” limitations.

Additionally, Respondents contended that “INVT has failed to prove that the accused 3G and LTE standards necessarily require the claimed ‘measurer’ / ‘measuring device’.” (RRBr. at 34.). Yet, the weight of evidence proves that, contrary to Respondents’ position, the Accused Products practice the “measurer” / “measuring device” limitations, at least some of the time. (*See, e.g.*, Tr. (William Mangione-Smith)²⁹ at 1033:5-19; Tr. (Nettleton) at 527:12-528:13, 530:22-531:18, 535:11-16, 539:1-541:4; CX-1561C (Zhang Dep. Tr.) at 121:6-8.).

2. Infringement Legal Standard

“Determination of infringement is a two-step process which consists of determining the

²⁹ When he testified at the Hearing on September 16, 2019, Dr. William Mangione-Smith worked for Phase Two, a consulting company he started to provide expert witness advice in the context of patent litigation. (Tr. (Mangione-Smith) at 927:7-10.). Dr. Mangione-Smith received bachelor’s, master’s and doctorate degrees in computer engineering from the University of Michigan. (*Id.* at 924:17-21.). Dr. Mangione-Smith was called by INVT to testify as an expert “regarding matters relating to the design, structure, function, and operation, including with respect to the operation of source code, of the accused products and any article asserted to infringe the asserted patents; the design, structure, function, and operation, including with respect to the operation of source code, of domestic industry products, and any research and development asserted to comprise INVT’s domestic industry; and other issues in connection with infringement the technical prong of the domestic industry requirement, and/or any other technical issue that may arise.” (CPSt. at 6-7.).

scope of the asserted claim (claim construction) and then comparing the accused product . . . to the claim as construed.” *Certain Sucralose, Sweeteners Containing Sucralose, and Related Intermediate Compounds Thereof*, Inv. No. 337-TA-604, Comm’n Opinion at 36 (U.S.I.T.C., April 28, 2009) (citing *Litton Sys., Inc. v. Honeywell, Inc.*, 140 F.3d 1449, 1454 (Fed. Cir. 1998)).

An accused device literally infringes a patent claim if it contains each limitation recited in the claim exactly. *Litton*, 140 F.3d at 1454. Each patent claim element or limitation is considered material and essential. *London v. Carson Pirie Scott & Co.*, 946 F.2d 1534, 1538 (Fed. Cir. 1991). In a Section 337 investigation, the complainant bears the burden of proving infringement of the asserted patent claims by a preponderance of the evidence. *Enercon GmbH v. Int’l Trade Comm’n*, 151 F.3d 1376, 1384 (Fed. Cir. 1998). If any claim limitation is absent, there is no literal infringement of that claim as a matter of law. *Bayer AG v. Elan Pharm. Research Corp.*, 212 F.3d 1241, 1247 (Fed. Cir. 2000).

3. INVT Failed to Prove That the “Encodes the Information” Limitations of Claims 3 and 4 of the ’590 Patent and Claim 4 of the ’587 Patent Are Satisfied by the Accused Products

As addressed above, the Accused Products, all of which comply with the 3G and LTE standards, perform encoding of channel quality information in a fundamentally different way than that required in the asserted claims or described in the shared specifications of the ’590 and ’587 patents.

Specifically, the 3G and/or LTE-compliant Accused Products use coding matrices to generate an encoded 20-bit CQI value from an initial CQI value (5 bits in 3G, 4 bits in LTE), where certain bits of the encoded 20-bit CQI value contain information from a most significant bit (“MSB”) of the initial CQI value, on the one hand, and the remaining bits of the initial CQI

Public Version

value, on the other hand. (Tr. (Nettleton) at 747:8-748:12; *accord*, Tr. (Wicker) at 1472:9-18, 1480:4-1481: RDX-0005C.0037.). In other words, certain bits contained in the encoded 20-bit CQI value represent a mathematical blending of information provided by bits in the initial CQI value. In other words, there is not a mathematical sequestration of a most significant bit or MSB, on the one hand, and the remaining bits, on the other hand, for the purposes of encoding. (*Id.*).

Nevertheless, INVT unsuccessfully argued that the CGI encoding matrices that the 3G and LTE standards require provide more error protection for the MSB than they do for less significant bits. As INVT explained, this is because all “1s” columns, as highlighted in Figure 14 below for the CGI encoding matrix are used in the 3G standard. (CBr. at 62-63.). This issue is material, and thus worthy of attention, only in the alternative. That alternative would arise only if the 112 ¶ 6 claim construction of “a coding device that encodes the information to obtain a code word” were to be rejected on review. In that situation, claim 4 of the ’587 patent would not be limited to Figure 15 and Embodiment 6 of the shared specification of the ’587/’590 patents. In that case, at least in theory, claim 4 could be broad enough to cover any CGI encoding technique for which “the most significant bit of the plurality of bits is less susceptible to errors in a propagation path than other bits of the plurality of bits.” (JX-0002 (’587 Patent), cl. 4.).

Figure 14: CGI Encoding Matrix Required by 3G Standard Highlighted to Show That Only the MSB Has a Corresponding Column ($M_{i,4}$) of all “1s”

TS 25.212 v.5.1.0 (CX-0058-0067-68)

4.7.1.2 Channel coding for HS-DPCCH channel quality information

The channel quality information is coded using a (20,5) code. The code words of the (20,5) code are a linear combination of the 5 basis sequences denoted $M_{i,j}$, defined in the table below.

Table 14: Basis sequences for (20,5) code

i	$M_{i,0}$	$M_{i,1}$	$M_{i,2}$	$M_{i,3}$	$M_{i,4}$
0	1	0	0	0	1
1	0	1	0	0	1
2	1	1	0	0	1
3	0	0	1	0	1
4	1	0	1	0	1
5	0	1	1	0	1
6	1	1	1	0	1
7	0	0	0	1	1
8	1	0	0	1	1
9	0	1	0	1	1
10	1	1	0	1	1
11	0	0	1	1	1
12	1	0	1	1	1
13	0	1	1	1	1
14	1	1	1	1	1
15	0	0	0	0	1
16	0	0	0	0	1
17	0	0	0	0	1
18	0	0	0	0	1
19	0	0	0	0	1

(CDX-0003.0078 (introduced during the testimony of Dr. Nettleton).).

INVT is correct that the weight of the evidence proves that the CGI encoding matrix that the 3G standard requires appears to provide more error protection for the MSB than it does for less significant bits. As shown in Figures 15 through 17 below, in the 3G standard, for the base station to incorrectly decode the most significant bit or MSB, the base station would have to interpret 12 or 20 bits erroneously, depending on the code word. (Tr. (Wicker) at 1602:12-21, 1603:17-1604:12.). To incorrectly decode any less significant bit, the base station would need to interpret only 8 bits erroneously. (*Id.* at 1602:22-1603:16.).

Figure 15: Chart from Dr. Wicker’s Expert Report Modified by INVT to Show that the Difference Between 3G Encodings of Two CGI Values that Differ Only in Terms of Most Significant Bit Is 12 or 20 Bits, as Measured by Actual Code Word Distance

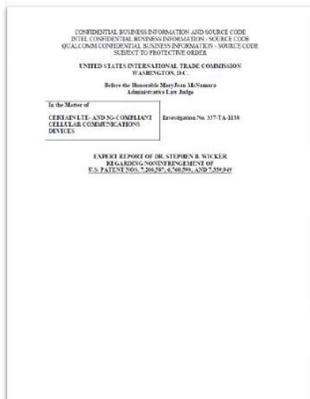

Wicker Reb. Rep. at 100.

As there are five basis elements, the corresponding binary code has 32 code words, all of which

Code word Number	Code word	Information Block	Weight
1	(000000000000000000000000)	00000	0
2	(111111111111111111111111)	00001	20
3	(0000000111111111000000)	00010	8
4	(1111111000000000111111)	00011	12
5	(0001111000011110000000)	00100	8
6	(1110000111100001111111)	00101	12
7	(0001111111110000000000)	00110	8
8	(1110000000011111111111)	00111	12
9	(0110011001100110000000)	01000	8
10	(1001100110011001111111)	01001	12
11	(0110011110011000000000)	01010	8
12	(1001100001100111111111)	01011	12
13	(0111100001110000000000)	01100	8
14	(1000011110000111111111)	01101	12
15	(0111001100001100000000)	01110	8
16	(1000011001110011111111)	01111	12
17	(1010101010101010100000)	10000	8
18	(0101010101010101011111)	10001	12
19	(1010101101010100000000)	10010	8
20	(0101010010101011111111)	10011	12
21	(1011010010110100000000)	10100	8
22	(0100101101001011111111)	10101	12
23	(1011010101001010000000)	10110	8
24	(0100101010110101111111)	10111	12
25	(1100110011001100000000)	11000	8
26	(0011001100110011111111)	11001	12
27	(1100110100110010000000)	11010	8
28	(0011001011001101111111)	11011	12
29	(1101001011010010000000)	11100	8
30	(0010110100101101111111)	11101	12
31	(1101001100101100000000)	11110	8
32	(0010110011010011111111)	11111	12

As there are five basis elements, the corresponding binary code has 32 code words, all of which

Code word Number	Code word	Information Block	Weight
1	(000000000000000000000000)	00000	0
2	(111111111111111111111111)	00001	20
3	(0000000111111111000000)	00010	8
4	(1111111000000000111111)	00011	12
5	(0001111000011110000000)	00100	8
6	(1110000111100001111111)	00101	12
7	(0001111111110000000000)	00110	8
8	(1110000000011111111111)	00111	12
9	(0110011001100110000000)	01000	8
10	(1001100110011001111111)	01001	12
11	(0110011110011000000000)	01010	8
12	(1001100001100111111111)	01011	12
13	(0111100001110000000000)	01100	8
14	(1000011110000111111111)	01101	12
15	(0111001100001100000000)	01110	8
16	(1000011001110011111111)	01111	12
17	(1010101010101010100000)	10000	8
18	(0101010101010101011111)	10001	12
19	(1010101101010100000000)	10010	8
20	(0101010010101011111111)	10011	12
21	(1011010010110100000000)	10100	8
22	(0100101101001011111111)	10101	12
23	(1011010101001010000000)	10110	8
24	(0100101010110101111111)	10111	12
25	(1100110011001100000000)	11000	8
26	(0011001100110011111111)	11001	12
27	(1100110100110010000000)	11010	8
28	(0011001011001101111111)	11011	12
29	(1101001011010010000000)	11100	8
30	(0010110100101101111111)	11101	12
31	(1101001100101100000000)	11110	8
32	(0010110011010011111111)	11111	12

Wicker Reb. Rep. at 100.

(CDX-0008C.0010-11 (introduced during the cross examination of Dr. Wicker)).

Figure 16: Chart from Dr. Wicker’s Expert Report Modified by INVT to Show that the Difference Between 3G Encodings of Two CGI Values that Differ Only in Terms of Least Significant Bit Is 8 Bits, as Measured by Actual Code Word Distance

As there are five basis elements, the corresponding binary code has 32 code words, all of which

Code word Number	Code word	Information Block	Weight
1	(000000000000000000000000)	00000	0
2	(111111111111111111111111)	00001	20
3	(0000000111111110000000)	00010	8
4	(1111111000000001111111)	00011	12
5	(0001111000011110000000)	00100	8
6	(1110000111100001111111)	00101	12
7	(0001111111100000000000)	00110	8
8	(1110000000011111111111)	00111	12
9	(0110011001100110000000)	01000	8
10	(1001100110011001111111)	01001	12
11	(0110011110011000000000)	01010	8
12	(1001100001100111111111)	01011	12
13	(0111100001111000000000)	01100	8
14	(1000011110000111111111)	01101	12
15	(0111100110000110000000)	01110	8
16	(1000011001111001111111)	01111	12
17	(1010101010101010100000)	10000	8
18	(0101010101010101011111)	10001	12
19	(1010101101010100000000)	10010	8
20	(0101010010101011111111)	10011	12
21	(1011010010110100000000)	10100	8
22	(0100101101001011111111)	10101	12
23	(1011010101001010000000)	10110	8
24	(0100101010110101111111)	10111	12
25	(1100110011001100000000)	11000	8
26	(0011001100110011111111)	11001	12
27	(1100110100110010000000)	11010	8
28	(0011001011001101111111)	11011	12
29	(1101001011010010000000)	11100	8
30	(0010110100101101111111)	11101	12
31	(1101001100101100000000)	11110	8
32	(0010110011010011111111)	11111	12

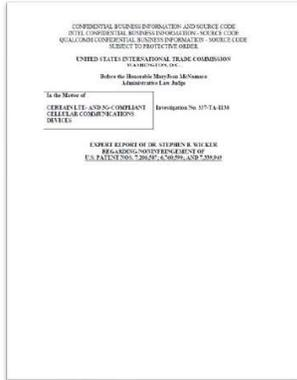

Wicker Reb. Rep. at 99-100.

14	(1000011110000111111111)	01101	12
30	(0010110100101101111111)	11101	12

(CDX-0008.0078 (introduced during the cross examination of Dr. Wicker).).

Figure 17: INVT’s Depiction of Side-by-Side Comparison Showing Enhanced Error Protection Provided by the 3G Standard for Changes in Most Significant Bit Versus Changes in Least Significant Bit, as Measured by Code Word Distance

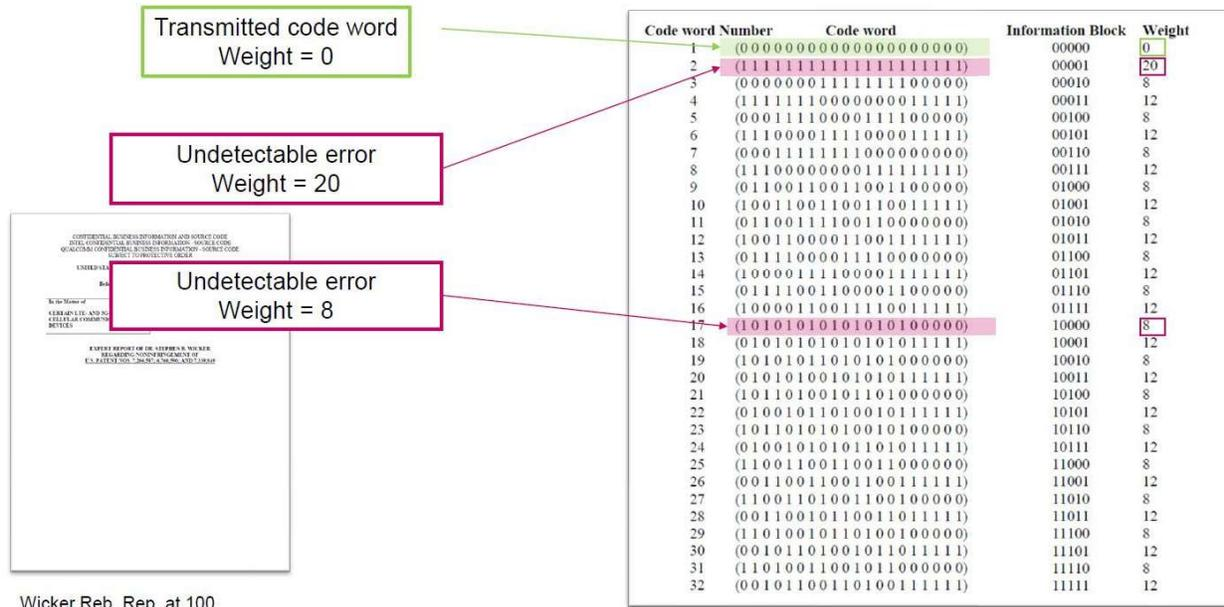

(CDX-0008.0024 (introduced during the cross examination of Dr. Wicker).).

INVT offered evidence that this protective effect is caused by multiplying the MSB bit by a coefficient of “1” in every single row of the encoding matrix, which is done in not only the 3G standard but also the LTE standard, as shown above in Figures 13 ($M_{i,4}$ column for 3G) and 13 ($M_{i,0}$ column for LTE). Specifically, as shown below in Figure 18, Panasonic, the original owner of the ’587 and ’590 Patents, submitted a proposal to ETSI, the creators of the LTE standard. (CX-0470.0002; Tr. (Wicker) at 1608:22-1609:10.). Panasonic’s proposed mapping the MSB to the all “1” column because “the all ‘1’ column provides some improvement on the error rate performance for the bit that is applied to that column.” (*Id.*). The creators of the LTE standard adopted Panasonic’s proposal, although it is unclear whether they agreed with Panasonic’s error-protection reasoning. (CX-0058.0068; Tr. (Wicker) at 1609:11-16.).

Figure 18: Panasonic’s Proposal to ETSI to Map the MSB to the All “1” Column of the LTE CGI Encoding Matrix to Increase Error Protection

TSG-RAN WG1 Meeting #52, CQI Coding over PUCCH (CX-0470-0001-0002)

CX-0470

SGPP TSG-RAN WG1 Meeting #52
15-16 February 2006 in Soriano, Italy

Source: Panasonic
Title: CQI coding over PUCCH
Agenda Item: 6.2
Document for: Discussion and Decision

1 Introduction

In RAN1 #10a as well as in 5GPP, a CQI coding table and structure has been agreed [1], including a mapping table to obtain the mapped bit from the CQI information bits. According to the definition of the current structure, the MSB of the CQI information bits is mapped to the bit that is applied to the all “1” column of the CGI encoding matrix. However, the current formula implies that the CQI information bit a_0 , representing the CQI index LSB, is applied to the column $M_{i_{in}}$ containing all “1”’s.

2 Discussion

According to [1], the working assumption for LTE is:

$$x_i = \sum_{j=0}^{N-1} (a_j \cdot 2^j) \cdot 2^{i \cdot 2}$$

where $i = 0, \dots, 15$

Table 1. Bit assignment for all PUCCH CQI coding for LTE

Q	0	1	2	3	4	5	6	7	8	9	10	11	12	13	14	15
0	0	0	0	0	0	0	0	0	0	0	0	0	0	0	0	0
1	0	0	0	0	0	0	0	0	0	0	0	0	0	0	0	0
2	0	0	0	0	0	0	0	0	0	0	0	0	0	0	0	0
3	0	0	0	0	0	0	0	0	0	0	0	0	0	0	0	0
4	0	0	0	0	0	0	0	0	0	0	0	0	0	0	0	0
5	0	0	0	0	0	0	0	0	0	0	0	0	0	0	0	0
6	0	0	0	0	0	0	0	0	0	0	0	0	0	0	0	0
7	0	0	0	0	0	0	0	0	0	0	0	0	0	0	0	0
8	0	0	0	0	0	0	0	0	0	0	0	0	0	0	0	0
9	0	0	0	0	0	0	0	0	0	0	0	0	0	0	0	0
10	0	0	0	0	0	0	0	0	0	0	0	0	0	0	0	0
11	0	0	0	0	0	0	0	0	0	0	0	0	0	0	0	0
12	0	0	0	0	0	0	0	0	0	0	0	0	0	0	0	0
13	0	0	0	0	0	0	0	0	0	0	0	0	0	0	0	0
14	0	0	0	0	0	0	0	0	0	0	0	0	0	0	0	0
15	0	0	0	0	0	0	0	0	0	0	0	0	0	0	0	0

3 Proposal

We propose that the most important CQI bit should be mapped to the all “1” column. Therefore we think that it is easiest if we correct the definition such that a_0 represents the CQI MSB and a_{19} represents the CQI LSB.

4 References

[1] 3GPP TS 36.213, “W1 Forward on PUCCH CQI coding”, 3GPP TSG-RAN WG1 Meeting #52a, Soriano, Spain, 14-16 January 2006.
[2] 3GPP TS 36.213 (2007-11), “Multiplexing and channel coding (FDD) Release 7”

TSG-RAN WG1 Meeting #52, CQI Coding over PUCCH (CX-0470-0002)

CX-0470

Title: CQI coding over PUCCH

According to the chairman notes, Table 1 has been agreed “with column $M_{i,5}$ moved before all other columns.”

In our understanding, the motivation to move column $M_{i,5}$ is motivated by the fact that the all “1” column provides some improvement on the error rate performance for the bit that is applied to that column. However the current formula implies that the CQI information bit a_0 , representing the CQI index LSB, is applied to the column $M_{i_{in}}$ containing all “1”’s.

Consequently we propose that for LTE the most important bit should be mapped to the all “1” column, i.e. it should be the CQI information MSB. Therefore we think that it is easiest if we correct the definition such that a_0 represents the CQI MSB and a_{19} represents the CQI LSB.

3 Proposal

We propose that the most important CQI bit should be mapped to the all “1” column. Therefore we think that it is easiest if we correct the definition such that a_0 represents the CQI MSB and a_{19} represents the CQI LSB.

4 References

[1] 3GPP TS 36.213, “W1 Forward on PUCCH CQI coding”, 3GPP TSG-RAN WG1 Meeting #52a, Soriano, Spain, 14-16 January 2006.
[2] 3GPP TS 36.213 (2007-11), “Multiplexing and channel coding (FDD) Release 7”

(CDX-0003C.0094-95 (excerpted from Dr. Nettleton’s stricken demonstrative slides to omit Dr. Nettleton’s opinions on this issue, while preserving factual information lifted from the face of CX-0470, which was not stricken).).

Respondents’ arguments to the contrary are unavailing. As shown below in Figure 19,

during direct examination, Dr. Wicker focused on the minimum code word distance metric of error protection and provided un rebutted testimony that the CGI code words used in the 3G and LTE standards all have a minimum code word distance of eight (8). (Tr. (Wicker) at 1484:19-1500:23, 1505:12-1516:23; RDX-0005.0049-50, 55-56.). Minimum code word distance is the smallest number of different bits between one valid code word and all of the other valid code words. (Tr. (Wicker) at 1486:1-6.). “Minimum distance tells us how much noise has to occur before we mistake one code word for another.” (Tr. (Wicker) at 1569:6-8.).

Figure 19: Respondents’ Depiction of 3G and LTE Codewords Having a Uniform Minimum Code Word Distance of “8”

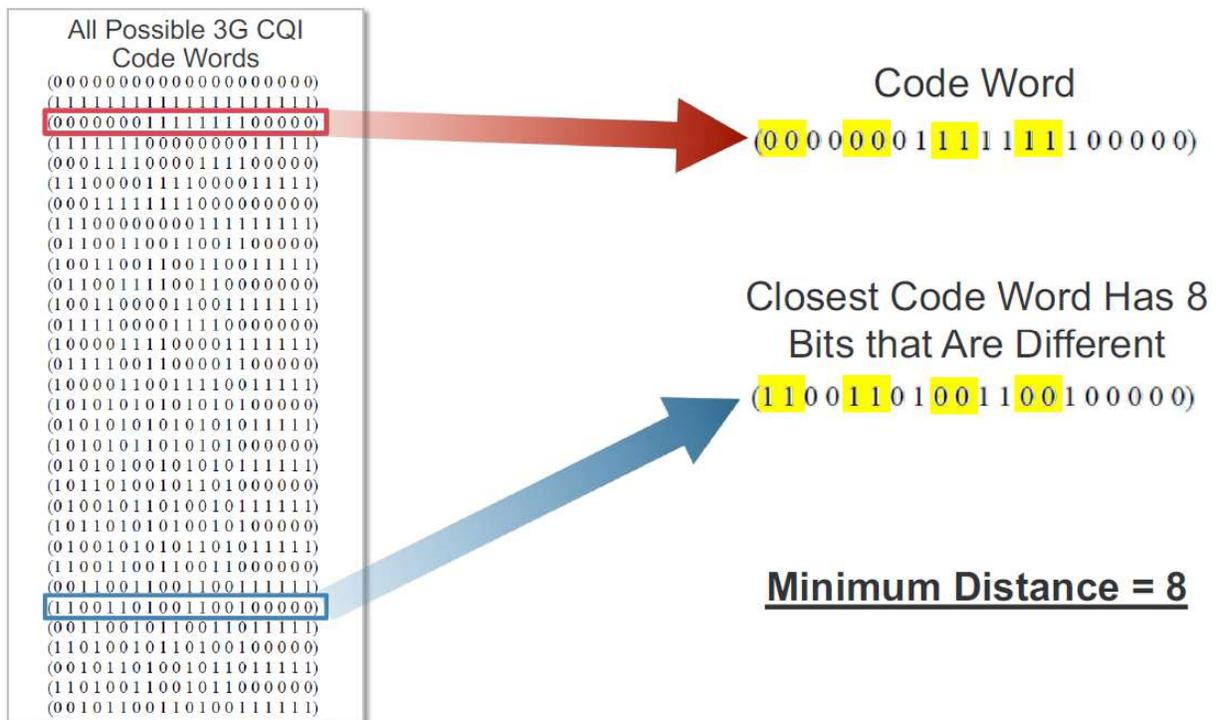

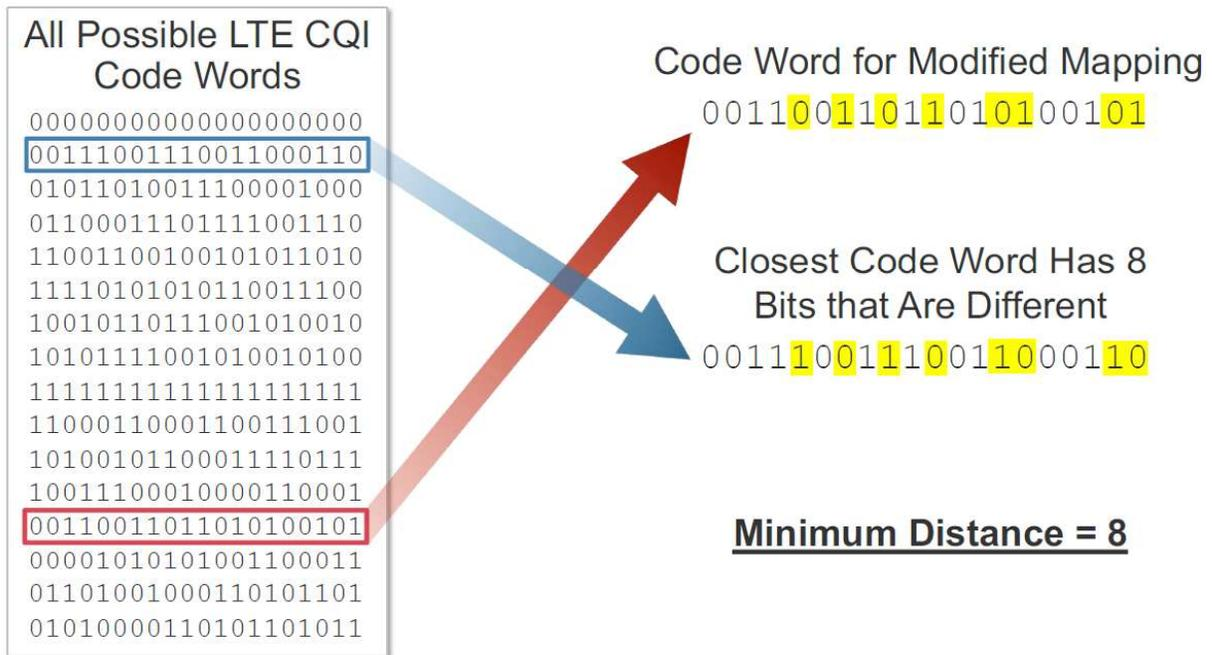

(RDX-0005.0050, 56 (introduced during the testimony of Dr. Wicker).).

While minimum code word distance appears to indicate error protection of code words as a whole, it appears that minimum code word distance is not necessarily a reliable indicator of the relative protection an encoding matrix affords certain encoded bits (e.g., MSB) over others (e.g., less significant bits). Dr. Nettleton testified that claim 4 of the '587 patent “has to do with actual distances, not minimum distances.” (Tr. (Nettleton) at 761:2-6.). For example, for the 3G and LTE matrices, it takes errors in no fewer than 8 bits to mistake one code word for another (a valid code word for a false code word). However, what is left unspecified with minimum code word distance is the likelihood of the false code word causing a large misreading of the CGI value (e.g., 8.7 v. 2.7) or a small misreading of that value (e.g., 8.7 v. 8.2).

Respondents argued, without evidence, that in a hypothetical, thorough statistical analysis of the likelihood of every potential error, that large and small deviations are equally likely.

(RRBr. at 15 (“And Dr. Wicker concluded that all the code words in the 3G and LTE standards

have the same code word minimum distance, which conclusively proves the 3G and LTE standards use equal error protection.”).).

However, with respect to error protection for intra-codeword MSBs versus less significant bits, evidence presented above suggests the opposite. In the context of 3G, for the base station to incorrectly decode a MSB, the station would have to interpret 12 or 20 bits erroneously, depending on the codeword sent by user equipment. (Tr. (Wicker) at 1602:12-21, 1603:17- 1604:12.). To incorrectly decode a least significant bit (“LSB”), the base station would need to interpret only 8 bits erroneously. (*Id.* at 1602:22-1603:16.).

Based on the testimony and the weight of the evidence, INVT failed to prove that the “encodes the information” limitations of claims 3 and 4 of the ’590 Patent and claim 4 of the ’587 patent are satisfied by the Accused Products. However, in the alternative, in the event that the 112 ¶ 6 claim construction of “a coding device that encodes the information to obtain a code word” in claim 4 of the ’587 patent is rejected on review such that the limitation covers any CGI encoding technique for which “the most significant bit of the plurality of bits is less susceptible to errors in a propagation path than other bits of the plurality of bits,” INVT would have proven by a preponderance of the evidence that this limitation is essential to the 3G and LTE standards.

4. INVT Has Proven Only That Certain Limitations of Claims 3 and 4 of the ’590 Patent and Claim 4 of the ’587 Patent Are Satisfied by the Accused Products and Are Essential to the 3G and LTE Standards

- a) Preamble. ’590 patent, cl. 3[pre]: A communication terminal apparatus comprising / ’587 patent, cl. 4[pre]: A communication terminal apparatus comprising**

The 3G and LTE standards require a communication terminal apparatus. (CX-0060.0038 (referring to user equipment or “UE”); CX-0067.0034 (same); Tr. (Nettleton) at 526:2-12.). Dr. Nettleton testified that a smartphone is one example of a UE. (Tr. (Nettleton) at 524:14-24;

Public Version

526:2-12.). Dr. Wicker also acknowledged that the 3G and LTE standards require hardware and software capable of performing the claimed coding. (Tr. (Wicker) at 1543:1-3.).

In post-Hearing briefing, Respondents did not contest that the Accused Products satisfy this limitation. (See RRBr. at 5-36.). Thus, Respondents have waived argument on this issue pursuant to Ground Rule 10.1.

For these reasons, INVT has proven by a preponderance of evidence that the Accused Products satisfy the preambles of claim 3 of the '590 patent and claim 4 of the '587 patent.

- b) **Measurer. '590 patent, cl. 3[a]: a measurer that measures a downlink channel quality and outputs information that is generated in association with said downlink channel quality and composed of a plurality of digits including an upper digit and a lower digit / '590 patent, cl. 4: The communication terminal apparatus according to claim 3, wherein the upper digit contains a most significant bit of the information / '587 patent, cl. 4[a]: a measuring device that measures reception quality of a pilot signal to output information having a plurality of bits that indicate the measured reception quality**

There is no dispute that the Accused Products practice the LTE and 3G standards. (Tr. (Respondents' Opening) at 29:22-25; Tr. (Wicker) at 1520:3-12.). However, according to Respondents, INVT failed to prove that the Accused Products definitively satisfy the claimed "measurer" / "measuring device" limitations of the asserted claims. (RRBr. at 34.). Staff disagreed. (See SBr. at 28 n.7.). According to Staff, INVT met its burden of proof by establishing that the 3G and LTE standards require the measurement of a pilot signal. (See *id.*). However, Respondents argued that "INVT and its experts never linked those measurements to the calculation of CQI, which is required by the claims." (RRBr. at 34.). Based upon the analysis that follows, it is finding that INVT and Staff's arguments are correct. INVT has proven by a preponderance of the evidence that the Accused Products satisfy the claimed "measurer" /

Public Version

“measuring device” limitations. While INVT’s evidentiary showing on these limitations could have been more robust and direct in nature, the evidence in its totality, even that which was indirect, was sufficient. Circumstantial evidence can be used to prove direct infringement. *Liquid Dynamics Corp. v. Vaughan Co.*, 449 F.3d 1209, 1219 (Fed. Cir. 2006).

The *Markman* Order construed “a measurer that ...” from claims 3 and 4 of the ’590 patent and “a measuring device that ...” from claim 4 of the ’587 patent. (*Markman* Order at 14-16.). Based upon those constructions, claim 4 of the ’587 patent requires “hardware and/or software that measures reception quality of a pilot signal to output information having a plurality of bits that indicate the measured reception quality.” Claims 3 and 4 of the ’590 patent requires “hardware and/or software that measures a downlink channel quality and outputs information that is generated in association with said downlink channel quality.” (*Id.* at 14–16.).

Respondents’ arguments amount to an exercise in “gotcha” litigation. Instead of undermining INVT’s evidence, Respondents quibbled with INVT’s quantum of proof. (RRBr. at 33-36.). Respondents also argued that “INVT chose to rely on the theory that the accused standards require a ‘measurer’ / ‘measuring device[,]’” without addressing the sections of INVT’s post-hearing briefing (or the evidence) in which INVT mapped the measurer and measuring device limitations directly to evidence (including source code) of how the Accused Products operate.

For example, using an iPhone 8 with a [REDACTED] that complies with 3G, Dr. Mangione-Smith, one of INVT’s experts who analyzed source code, testified that, [REDACTED]
[REDACTED]
[REDACTED]. (Tr. (Mangione-Smith) at 934:4-22; CPX-0048C at ll. 5867-5942.). Dr. Mangione-Smith also testified that the

Public Version

X16 modem in the iPhone 8 contains LTE software [REDACTED]. (Tr. (Mangione-Smith) at 945:13-16; CPX-0054C at l. 154.). According to Dr. Mangione-Smith, [REDACTED]
[REDACTED]
[REDACTED]. (Tr. (Mangione-Smith) at 945:17-946:15; CPX-0054C at ll. 481-490; *see id.*, CPX-0054C at 34; CBr. at 70-76, 82-85.).

By contrast, Respondents' expert, Dr. Wicker, who had examined the 3G and LTE standards and the operation of the Accused Products (including source code), remained largely silent about the presence of CQI measuring functionality in the Accused Products. Instead, Respondents and Dr. Wicker focused on the metes and bounds of INVT's expert reports:

Q. Okay. And then the next question is, this goes back to the measuring device and the coder, do I understand correctly that because the Complainant ... did not exactly show what the measuring device was, you yourself then didn't offer an opinion on that since they didn't actually point to a measuring device or where it existed?

A. That's right, Your Honor. I can't say whether they didn't point at something so I could say well you're right or your wrong. And so my opinion is that he they didn't point at a measurer.

Q. Right, but you didn't do your own evaluation ... by looking at the accused products to determine what the measurer is?

A. No, Your Honor I did not do that.

(Tr. (Judge McNamara in a colloquy with Dr. Wicker) at 1664:5-24; *see also* Tr. (Benjamin Goldberg)³⁰ at 1965:7-13 [REDACTED]
[REDACTED].

Dr. Wicker even suggested that it was theoretically possible for the Accused Products to

³⁰ When he testified during the Hearing on September 19, 2019, Benjamin F. Goldberg was "a tenured associate professor of computer science at New York University" and "the director of the graduate program in computer science at New York University." (Tr. (Goldberg) at 1951:9-12.). Respondents called Dr. Goldberg as a technical expert to testify about "the operation of source code for the Accused Products and the Domestic Industry Products as it relates to all asserted patents." (RPSt. at 2.).

Public Version

measure channel quality without practicing one of the asserted claims. (Tr. (Wicker) at 1530:14-15 (3G and LTE standards “don’t specify a particular measurer”), 1530:19-1531:9 (“blind estimation” and “retransmission counting” alternatives to using a “measurer” to generate CQI value)). However, because neither Respondents nor their experts offered evidence with respect to the feasibility of their CGI measurement alternatives in the context of the Accused Products, Dr. Wicker’s alternatives are accorded little weight in the evidentiary analysis presented. (See Tr. (Wicker) at 1530:19-1531:17, 1662:22-1664:4.).

In sum, INVT satisfied its burden of proving by a preponderance of the evidence that the Accused Products possess the claimed measurer and measuring device.

For 3G, the TS 25.215 specification³¹ requires that the UE be capable of measuring the received signal power of the common pilot channel. (CX-0061.0008; Tr. (Nettleton) at 529:23-530:4.). Dr. Wicker conceded this. (Tr. (Wicker) at 1530:13-14.). Additionally, the TS 25.214 standard requires that a UE report a “channel quality indicator” (CQI) to the base station. (CX-0060.0038; Tr. (Nettleton) at 527:12-528:1.). The 3G standard requires that the CQI value be determined by the UE “[b]ased on an unrestricted observation interval.” (CX-0060.0038.). As Dr. Nettleton explained, “the manufacturer has to decide what the interval is, but the point is that you look at the measurement over a period of time.” (Tr. (Nettleton) at 528:7-9.). As shown below in Figure 20, TS 25.214 also requires that “[f]or the purposes of CQI reporting, the UE shall assume a total received HS-PDSCH power of $PHSPDSCH = PCPICH + \Gamma + \Delta$ in dB,”

³¹ This specification is version 3.1.1, entitled “3rd Generation Partnership Project; Technical Specification Group Radio Access Network; Physical Layer – Measurements (FDD),” and dated December 1999. (CX-0061.0002.).

where PCPICH is the measured power of the common pilot channel. (CX-0060.0038-39.). The TS 25.212 specification³² requires that the CQI value consists of a plurality of digits, denoted in the standard as “a0, a1, a2, a3, a4 (where a0 is LSB [least significant bit] and a4 is MSB [most significant bit]).” (CX-0058.0068; Tr. (Nettleton) at 524:3-7.).

Figure 20: In 3G, Linking CQI Calculation to Measured Power of Pilot Channel

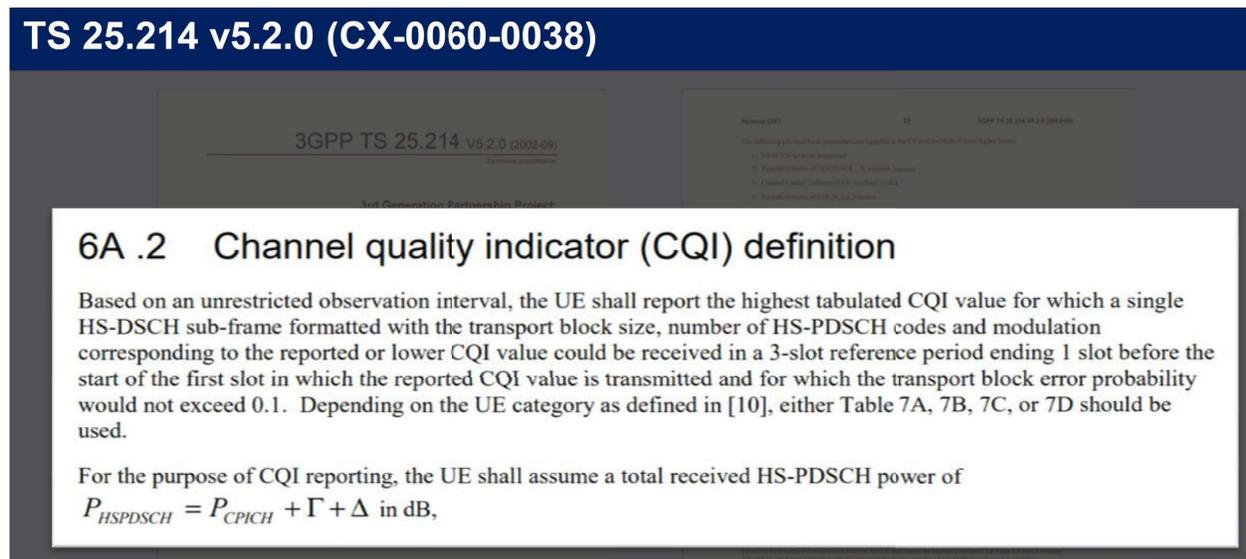

(CDX-003.0024 (introduced during the testimony of Dr. Nettleton).).

For LTE, the TS 36.214 specification³³ requires that the UE be capable of measuring the reference signal received power based on measurements of cell-specific reference signals. (CX-0070.0008; Tr. (Nettleton) at 541:14-542:2.). The TS 36.133 specification³⁴ requires that “[t]he

³² This specification is version 5.1.0, entitled “3rd Generation Partnership Project; Technical Specification Group Radio Access Network; Multiplexing and channel coding (FDD),” and dated June 2002. (CX-0058.0002.).

³³ This specification is version 8.3.0, entitled “3rd Generation Partnership Project; Technical Specification Group Radio Access Network; Evolved Universal Terrestrial Radio Access (E-UTRA); Physical Layer – Measurements,” and dated May 2008. (CX-0070.0002.).

³⁴ This specification is version 8.4.0, entitled “3rd Generation Partnership Project; Technical Specification Group Radio Access Network; Evolved Universal Terrestrial Radio Access (E-UTRA); Requirements for support of radio resource management,” and dated December 2008. (CX-0062.0002.).

Public Version

UE shall monitor the downlink link quality based on the cell-specific reference signal in order to detect the downlink radio link quality of the serving cell.” (CX-0062.0034.). The UE must also “output information generated in association with said downlink channel quality” in the form of a CQI value, as required by the TS 36.213 specification.³⁵ (CX-0067.0034.). As shown below in Figure 21, the LTE CQI value is determined by the UE “[b]ased on an unrestricted observation interval.” (*Id.*). Dr. Nettleton tied these two requirements together. He testified that the UE must contain a measurer that measures downlink channel quality and outputs information that is generated in association with said downlink channel quality (the CQI value). (Tr. (Nettleton) 539:1-541:4.). The TS 36.212 specification³⁶ requires the CQI value to consist of a plurality of digits denoted in the standard as “a0 , a1 , a2 , a3,..., aA-1 with a0 corresponding to the first bit of the first field in each of the tables . . . and aA-1 corresponding to the last bit in the last field in each of the tables. The first bit of each field corresponds to MSB [most significant bit] and the last bit LSB [least significant bit].” (CX-0065.0034; Tr. (Nettleton) at 545:24-546:25.).

³⁵ This specification is version 8.3.0, entitled “3rd Generation Partnership Project; Technical Specification Group Radio Access Network; Evolved Universal Terrestrial Radio Access (E-UTRA); Physical Layer Procedures,” and dated May 2008. (CX-0067.0002.).

³⁶ This specification is version 8.3.0, entitled “3rd Generation Partnership Project; Technical Specification Group Radio Access Network; Evolved Universal Terrestrial Radio Access (E-UTRA); Multiplexing and channel coding,” and dated May 2008. (CX-0065.0002.).

Figure 21: In LTE, Linking CQI Calculation to Measured Power of Reference Signal

TS 36.213 v8.3.0 (CX-0067-0034)

3GPP TS 36.213 v8.3.0 (2009-05)
3rd Generation Partnership Project

7.2.3 Channel quality indicator (CQI) definition

The number of entries in the CQI table for a single TX antenna = 16 as given by Table 7.2.3-1.

A single CQI index corresponds to an index pointing to a value in the CQI table. The CQI index is defined in terms of a channel coding rate value and modulation scheme (QPSK, 16QAM, 64QAM),

Based on an unrestricted observation interval in time and frequency, the UE shall report the highest tabulated CQI index for which a single PDSCH sub-frame with a transport format (modulation and coding rate) and number of REs corresponding to the reported or lower CQI index that could be received in a 2-slot downlink subframe aligned, reference period ending z slots before the start of the first slot in which the reported CQI index is transmitted and for which the transport block error probability would not exceed 0.1.

CQI	Modulation	Coding rate (R)	Modulation and coding scheme (MCS)
1	QPSK	1/4	QPSK 1/4
2	QPSK	1/3	QPSK 1/3
3	QPSK	1/2	QPSK 1/2
4	QPSK	2/3	QPSK 2/3
5	16QAM	1/4	16QAM 1/4
6	16QAM	1/3	16QAM 1/3
7	16QAM	1/2	16QAM 1/2
8	16QAM	2/3	16QAM 2/3
9	64QAM	1/4	64QAM 1/4
10	64QAM	1/3	64QAM 1/3
11	64QAM	1/2	64QAM 1/2
12	64QAM	2/3	64QAM 2/3
13	64QAM	3/4	64QAM 3/4
14	64QAM	4/5	64QAM 4/5
15	64QAM	5/6	64QAM 5/6

(CDX-003.0044 (introduced during the testimony of Dr. Nettleton)).

Respondents conceded in the alternative that INVT provided evidence that the Accused Products contain the pilot signal measurement: “Even if the accused standards require a pilot signal and describe measuring that pilot signal[.]” (RRBr. at 34.). Nevertheless, Respondents continued to argue that “INVT and its experts never linked those measurements to the calculation of CQI, which is required by the claims.... Mere measurement in and of itself is not enough—the measurements have to be used to calculate the output CQI information.” (*Id.*). Yet, Dr. Mangione-Smith appeared to connect these dots based upon his review of the source code associated with the Accused Products:

Q. So, Dr. Mangione-Smith, I’ll give you a moment to read this, and if you could explain to me where and I’m not asking you to go into details but what I’m looking for is where you performed the interaction of the hardware, between the hardware on the UE and the software code on the UE.

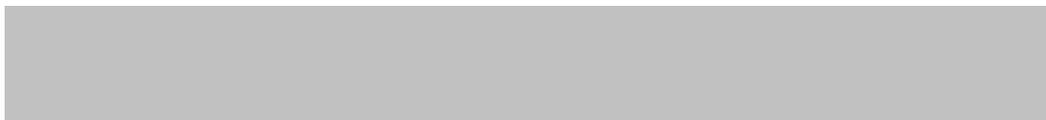

[REDACTED]

(Tr. (Mangione-Smith) at 1033:5-19; *see also* Tr. (Nettleton) at 527:12-528:13, 530:22-531:18, 535:11-16, 539:1-541:4.).

[REDACTED]

[REDACTED]. (CX-1561C (Wei Zhang Dep. Tr.)³⁷ at 121:6-8 [REDACTED]
[REDACTED]).

Based upon a preponderance of evidence as described above, including Dr. Nettleton’s interpretation of that evidence from the perspective of one of ordinary skill in the art, and Respondents’ lack of rebuttal evidence, INVT has proven that the Accused Products satisfy the claimed measurer and measuring device limitations of the asserted claims.

a) Transmitter. ’590 patent, cl. 3[c]: a transmitter that transmits the encoded information to a base station apparatus / ’587 patent, cl. 4[c]: a transmitter that transmits the code word

The claimed “transmitter” limitations are essential to the 3G and LTE standards. Both the 3G and LTE standards require that the encoded CQI value be transmitted. (CX-0060.0038; CX-0067.0034; Tr. (Nettleton) at 590:3-592:13.).

In post-hearing briefing, Respondents did not contest that the Accused Products satisfy these limitations. (*See* RRBr. at 5-36.). Thus, Respondents have waived argument on this issue pursuant to Ground Rule 10.1.

For these reasons, INVT has proven by a preponderance of evidence that the Accused Products satisfy the “transmitter” limitations of claims 3 and 4 of the ’590 patent and claim 4 of the ’587 patent.

³⁷ Wei Zhang is a “Software Engineer at Apple. Mr. Zhang is knowledgeable about the functionality of Apple’s Accused Products.” (RPSt. at 4.). Mr. Zhang’s deposition was taken on January 18, 2019. (CX-1561C at Cover.).

Public Version

However, INVT has failed to prove by a preponderance of the evidence that the Accused Products satisfy claims 3 and 4 of the '590 patent and claim 4 of the '587 patent. Specifically, INVT failed to prove by a preponderance of evidence that the Accused Products meet the “encodes the information” limitations of these claims. In the Accused Products practicing the 3G and LTE standards, information associated with the upper digit or MSB is not assigned exclusively to codeword bits that are separate and distinct from the code word bits that correspond to information associated with a lower digit or less significant bit, as required by the '587/'590 patents. (*See* JX-0001 ('590 patent) at 19:34-21:42.).

C. INVT Failed to Prove Technical Domestic Industry for the '587/'590 Patents

1. Technical Domestic Industry Legal Standard

The domestic industry requirement consists of a “technical prong” and an “economic prong.” *See, e.g., Certain Elec. Devices, Including Wireless Commc'n Devices, Portable Music & Data Processing Devices, & Tablet Computs.*, Inv. No. 337-TA-794, Order No. 88, 2012 WL 2484219, at *3 (June 6, 2012); *Certain Unified Commc'ns Sys., Prods. Used with Such Sys., and Components Thereof*, Inv. No. 337-TA-598, Order No. 9 at 2 (Sept. 5, 2007) (“*Communications Systems*”). A complainant satisfies the “technical prong” of the domestic industry requirement when it proves that its activities relate to an article “protected by the patent.” *See Commc'ns Sys.*, Order No. 9 at 2.

A complainant in a patent-based Section 337 investigation must demonstrate that it is practicing or exploiting the patents at issue. *See* 19 U.S.C. § 1337(a)(2) and (3); *Certain Microsphere Adhesives, Process for Making Same, and Prods. Containing Same, Including Self-Stick Repositionable Notes*, Inv. No. 337-TA-366, Comm'n Op. at 8, Pub. No. 2949 (U.S.I.T.C. Jan. 16, 1996) (“*Microsphere Adhesives*”). “In order to satisfy the technical prong of the

Public Version

domestic industry requirement, it is sufficient to show that the domestic industry practices any claim of that patent, not necessarily an asserted claim of that patent.” *Certain Ammonium Octamolybdate Isomers* (“Certain Isomers”), Inv. No. 337-TA-477, Comm’n Op. at 55 (U.S.I.T.C. Jan. 5, 2004).

The test for claim coverage for purposes of the technical prong of the domestic industry requirement is the same as that for infringement. *Certain Doxorubicin and Preparations Containing Same*, Inv. No. 337-TA-300, Initial Determination at 109, 1990 WL 710463 (U.S.I.T.C. May 21, 1990), *aff’d*, Views of the Commission at 22 (October 31, 1990) (“Doxorubicin”). “First, the claims of the patent are construed. Second, the complainant’s article or process is examined to determine whether it falls within the scope of the claims.” *Id.* The technical prong of the domestic industry can be satisfied either literally or under the doctrine of equivalents. *Certain Dynamic Sequential Gradient Devices and Component Parts Thereof*, Inv. No. 337-TA-335, Initial Determination at 44, Pub. No. 2575 (U.S.I.T.C. Nov. 1992).

“[T]o satisfy the technical prong with regard to a method claim, it must be shown the method is in fact practiced by someone.” *Certain Elec. Devices, Including Mobile Phones and Tablet Computs., and Components Thereof*, Inv. No. 337-TA-847, 2013 WL 5822559, at *131 n.33 (U.S.I.T.C. Sept. 23, 2013) (“Electronic Devices”).

2. Technical Domestic Industry Analysis

For the ’587 and ’590 patents, Respondents made exactly the same arguments with respect to INVT’s DI Products, that they do not satisfy the technical domestic industry requirement, as they did for non-infringement. Respondents added nothing new that was specifically geared to INVT’s DI Products to explain why they do not satisfy the technical domestic industry requirement. (RRBr. at 36.). There was no dispute that the DI Products,

which incorporate the same [REDACTED] components as many of the Respondents' Accused Products, operate, in relevant part, the same way as the Accused Products. (CBr. at 87; RRB. at 36.). As INVT's expert Dr. Nettleton conceded, and Respondents and Staff agreed, for the '587 and '590 patents, the technical prong of domestic industry should rise and fall with infringement by the Accused Products. (Tr. (Nettleton) at 651:25-15; RRB. at 36; SBr. at 43.).

Consequently, for the '587 and '590 patents, INVT failed to prove the technical prong of domestic industry for the same reasons that INVT failed to prove infringement.

D. Respondents Failed to Prove Invalidity of the Asserted Claims

Respondents argued that claim 4 of the '587 patent and claims 3 and 4 of the '590 patent are obvious³⁸ over: (1) PCT App. No. PCT/US98/23428 ("Padovani") (RX-1618) and EP 0680157B1 ("Seshadri") (RX-1635); (2) Padovani and U.S. Patent No. 6,470,470 ("Jarvinen") (RX-1640); (3) Padovani and U.S. Patent No. 5,502,744 ("Marshall") (RX-1630); and (4) the Applicant's Admitted Prior Art ("AAPA")³⁹ and the TS 25.212 v3.2.0 specification⁴⁰ (RX-1606).⁴¹

³⁸ Respondents did not raise anticipation as a ground for invalidity.

³⁹ AAPA is prior art identified and discussed in the shared specification of the '587/'590 patents, particularly the "Background Art" section of that specification. (RBr. at 18.).

⁴⁰ This specification is version 3.2.0, entitled "Universal Mobile Telecommunications System (UMTS); Multiplexing and channel coding (FDD)," and dated March 2000. (CX-1606.0002.).

⁴¹ Dr. Nettleton conceded that, during *inter partes* review ("IPR"), the Patent Trial and Appeal Board ("PTAB") did not consider the prior art combinations that Respondents use here for invalidity. (Tr. (Nettleton) at 2461:1-2462:6.). Specifically, although Padovani was discussed in prior IPRs targeting the '587 and '590 patents, in those IPRs, the combination of Padovani with Seshadri, Marshall, or Jarvinen was not considered by the PTAB. (*Id.*; see also CX-1534 (for '587 patent, Mar. 5, 2019 decision denying institution), CX-1535 (for '587 patent, Feb. 19, 2019 decision denying institution).). Moreover, the combination of AAPA and TS 25.212 V3.2.0 reference was not considered by the PTAB. (*Id.*).

1. Obviousness Overview

The dispute between the Parties here appears to be limited and discreet. INVT disputed only: (1) whether Respondents' prior art combinations disclose the "encodes the information" limitations of claim 4 of the '587 patent and claims 3 and 4 of the '590 patent; and (2) whether a person of ordinary skill in the art would be motivated to make, and have a reasonable expectation of success in making, Respondents' combinations. (CRBr. at 6-9).⁴²

For the reasons set forth below, Respondents have not proven by clear and convincing evidence that the type of error protection that the '587 and '590 patents teach was obvious. Staff agreed. (SBr. at 43-55.).

2. Obviousness Legal Standard

Under 35 U.S.C. § 103(a), a patent is valid unless "the differences between the subject matter sought to be patented and the prior art are such that the subject matter as a whole would have been obvious at the time the invention was made" to a person having ordinary skill in the art. 35 U.S.C. § 103(a). The ultimate question of obviousness is a question of law, but "it is well understood that there are factual issues underlying the ultimate obviousness decision."

Richardson-Vicks, 122 F.3d 1476, 1479 (Fed. Cir. 1997) (citing *Graham v. John Deere Co. of Kansas City*, 383 U.S. 1, 17 (1966)).

After claim construction, "[t]he second step in an obviousness inquiry is to determine whether the claimed invention would have been obvious as a legal matter, based on underlying

⁴² "Jarvinen cannot disclose the claimed 'coder' or 'coding device' as it does not disclose encoding the claimed 'information' relating to channel quality. ... Marshall does not 'encode' information at all. Instead, it protects information by employing different modulation schemes ... Seshadri discloses yet another voice data encoder, and therefore does not disclose the claimed "coder" or "coding device" ... Respondents take an encoding scheme from one context, TFCI, and apply it in a separate and distinct context, the DRC message discussed in the background of the patents." (CRBr. at 6-9.).

Public Version

factual inquiries including: (1) the scope and content of the prior art, (2) the level of ordinary skill in the art, (3) the differences between the claimed invention and the prior art, and (4) secondary considerations of non-obviousness.” *Smiths Indus. Med. Sys., Inc. v. Vital Signs, Inc.*, 183 F.3d 1347, 1354 (Fed. Cir. 1999) (citing *Graham*, 383 U.S. at 17). The existence of secondary considerations of non-obviousness does not control the obviousness determination; a court must consider “the totality of the evidence” before reaching a decision on obviousness. *Richardson-Vicks*, 122 F.3d at 1483. “Relevant secondary considerations include commercial success, long-felt but unsolved needs, failure of others, and unexpected results.” *Allergan, Inc. v. Sandoz Inc.*, 726 F.3d 1286, 1291 (Fed. Cir. 2013) (citing *KSR Int’l Co. v. Teleflex Inc.*, 550 U.S. 389, 399 (2007)) (other citations omitted).

The Supreme Court clarified the obviousness inquiry in *KSR*. The Supreme Court said:

When a work is available in one field of endeavor, design incentives and other market forces can prompt variations of it, either in the same field or a different one. If a person of ordinary skill can implement a predictable variation, § 103 likely bars its patentability. For the same reason, if a technique has been used to improve one device, and a person of ordinary skill in the art would recognize that it would improve similar devices in the same way, using the technique is obvious unless its actual application is beyond his or her skill. *Sakraida* and *Anderson’s-Black Rock* are illustrative—a court must ask whether the improvement is more than the predictable use of prior art elements according to their established functions.

Following these principles may be more difficult in other cases than it is here because the claimed subject matter may involve more than the simple substitution of one known element for another or the mere application of a known technique to a piece of prior art ready for the improvement. Often, it will be necessary for a court to look to interrelated teachings of multiple patents; the effects of demands known to the design community or present in the marketplace; and the background knowledge possessed by a person having ordinary skill in the art, all in order to determine whether there was an apparent reason to combine the known elements in the fashion claimed by the patent at issue. To facilitate review, this analysis should be made explicit.

* * *

The obviousness analysis cannot be confined by a formalistic conception of the words teaching, suggestion, and motivation, or by overemphasis on the importance

of published articles and the explicit content of issued patents. The diversity of inventive pursuits and of modern technology counsels against limiting the analysis in this way. In many fields it may be that there is little discussion of obvious techniques or combinations, and it often may be the case that market demand, rather than scientific literature, will drive design trends. Granting patent protection to advances that would occur in the ordinary course without real innovation retards progress and may, in the case of patents combining previously known elements, deprive prior inventions of their value or utility.

KSR, 550 U.S. at 417-19.

The Federal Circuit has since held that when a patent challenger contends that a patent is invalid for obviousness based on a combination of several prior art references, “the burden falls on the patent challenger to show by clear and convincing evidence that a person of ordinary skill in the art would have had reason to attempt to make the composition or device, or carry out the claimed process, and would have had a reasonable expectation of success in doing so.”

PharmaStem Therapeutics, Inc. v. ViaCell, Inc., 491 F.3d 1342, 1360 (Fed. Cir. 2007) (citations omitted).

The TSM⁴³ test, flexibly applied, merely assures that the obviousness test proceeds on the basis of evidence--teachings, suggestions (a tellingly broad term), or motivations (an equally broad term)--that arise before the time of invention as the statute requires. As *KSR* requires, those teachings, suggestions, or motivations need not always be written references but may be found within the knowledge and creativity of ordinarily skilled artisans.

Ortho-McNeil Pharm., Inc. v. Mylan Labs., Inc., 520 F.3d 1358, 1365 (Fed. Cir. 2008).

3. Prior Art Background: Padovani and AAPA

Three (3) concepts broadly permeate the asserted claims: (1) measuring; (2) encoding; and (3) transmitting. Dr. Nettleton, Respondents’ expert, conceded that the claimed measuring and transmitting were concepts and functions known in the prior art. (Tr. (Nettleton) at 2443:7-

⁴³ TSM is an acronym that stands for teaching, suggestion, motivation.

Public Version

13, 2445:10-18.). Dr. Nettleton also conceded that encoding channel quality information was known in the prior art, as taught in Padovani. (Tr. (Nettleton) at 2440:7-19, 2442:7-10, 2447:5-7, 2448:2-5.). Dr. Wicker and Dr. Nettleton agreed that, as is evident from Respondents' selection of prior art references pertaining to speech encoding, unequal error protection⁴⁴ was also known in the speech encoding prior art. (RX-1635 ("Seshadri"); (RX-1640 ("Jarvinen"); RX-1630 ("Marshall"); see Tr. (Nettleton) at 2449:14-16; Tr. (Wicker) at 1554:15-1555:7.). However, as discussed in more detail below, it appears that unequal error protection was not present in the prior art in the context of the '587/590 patent's specific application of unequal error protection: encoding channel quality information. (See JX-0001 ('590 patent) at 19:34-21:42.).).

In addition to the three (3) prior art references identified by Respondents, the "Background Art" section of the shared '587/'590 patent specification discusses what was known in the art at that time, which Respondents have coined "Applicant's Admitted Prior Art" or "AAPA." (JX-0002 ('587 Patent) at 1:15-2:33.). For example, the "Background Art" section states that a "communication terminal [that] estimates the downlink channel quality using a CIR (desired carrier to interference ratio) based on the pilot signal" was well known in the prior art. (*Id.* at 1:31-35.). The '587 and '590 patents' shared specification also explains that it was well

⁴⁴ This refers to unequal error protection as taught by the '587/'590 patents, whereby a most significant bit (MSB) is encoded with more bits than is a least significant bit (LSB). (See JX-0001 ('590 patent) at 19:34-21:42.).).

Public Version

known for communication terminals⁴⁵ to use the estimated downlink channel⁴⁶ quality to select a communication mode and transmit that mode to the base station in a DRC, or data rate control, message.⁴⁷ (*Id.* at 1:35–41.). The communication mode that a DRC message sends corresponds to “a combination of packet length, coding method, and modulation method.” (*Id.*). It was well-known for DRC signals to be “represented by numbers from 1 to N, with a higher number indicating a proportionally better downlink channel quality.” (*Id.* at 1:53–56.).

Padovani is a patent application that was published on May 14, 1999, and is prior art under pre-AIA 35 U.S.C. § 102(b).⁴⁸ (RX-1618 (Padovani) at Cover.). Padovani describes a

⁴⁵ “In a cellular communication system, one base station performs radio communication with a plurality of communication terminals simultaneously, and therefore, as demand has increased in recent years, so has the need for higher transmission efficiency.” (JX-0001 (’590 patent) at 1:14-19.). There is no dispute among the Parties that the Accused Products, including smartphones, tablets, and smart watches, are “communication terminal[s]” as that term was used in the ’587/’590 patent specification.

⁴⁶ In LTE and 3G systems, data is downloaded from a base station to a UE via a downlink channel. (Tr. (Nettleton) at 510:2-511:22.).

⁴⁷ By way of reminder, “each communication terminal selects a communication mode, which is a combination of packet length, coding method, and modulation method, and transmits a data rate control (referred to as ‘DRC’) signal indicating the communication mode to the base station.” (JX-0002 (’587 Patent) at 1:35-41.).

⁴⁸ Prior to the America Invents Act (“AIA”), 35 U.S.C. § 102(e), (f), (g)(1) and (g)(2) read, in relevant part: “A person shall be entitled to a patent unless—
(e) the invention was described in (1) an application for patent, published under section 122(b), by another filed in the United States before the invention by the applicant for patent or (2) a patent granted on an application for patent by another filed in the United States before the invention by the applicant for patent, except that an international application filed under the treaty defined in section 351(a) shall have the effects for the purposes of this subsection of an application filed in the United States only if the international application designated the United States and was published under Article 21(2) of such treaty in the English language; or
(f) he did not himself invent the subject matter sought to be patented, or
(g)(1) during the course of the an interference conducted under section 135 or section 291, another inventor involved therein establishes, to the extent permitted in section 104, that before such person’s invention thereof the invention was made by such other inventor and not abandoned, suppressed, or concealed, or
(g)(2) before such person’s invention thereof, the invention was made in this country by another inventor who had not abandoned, suppressed, or concealed it. In determining priority of invention under this

Public Version

spread spectrum CDMA⁴⁹ communication system where a mobile station transmits to a base station a data request message containing an indication of forward link channel quality. (*Id.* at Abstract, 9:8-10:6.). Padovani was assigned initially to Qualcomm Incorporated (“Qualcomm”). (*Id.* at Cover.).

Padovani discloses the measuring limitations of the asserted claims, as shown below in Figure 22. As Dr. Nettleton explained, Padovani discloses “measuring signal-to-noise-and-interference ratio for a forward link pilot signal.” (Tr. (Nettleton) at 2443:7-13, 2445:10-18; *see also* Tr. (Wicker) at 1545:23-1547:6.). Padovani states that “the mobile station measures the signal-to-noise-and-interference ratio (C/I) of the forward link signals (e.g., the forward link pilot signals)[.]” (RX-1618 (Padovani) at 7:34-36; *see also id.* at 5:34–38, 9:11–14, 9:34–37, Fig. 5.).

subsection, there shall be considered not only the respective dates of conception and reduction to practice of the invention, but also the reasonable diligence of one who was first to conceive and last to reduce to practice, from a time prior to conception by the other.”

Post-AIA, 102(e) is now in 102(a)(2); 102(f) and (g) are included in 102(a)(1). 35 U.S.C. § 102(a)(1) and (2) read as follows: “(a) A person shall be entitled to a patent unless—
(1) the claimed invention was patented, described in a printed publication, or in public use, on sale, or otherwise available to the public before the effective filing date of the claimed invention; or
(2) the claimed invention was described in a patent issued under section 151, or in an application for patent published or deemed published under section 122(b), in which the patent or application, as the case may be, names another inventor and was effectively filed before the effective filing date of the claimed invention.”

⁴⁹ Dr. Nettleton described CDMA as “a method of using language in a way that only two people can understand it. So if by analogy, if you have a whole bunch of people with international backgrounds and they are milling around and obviously it condenses into a situation where two people are talking to each other in their own language, a lot of other people are talking to each other in the same room in different languages, but the people with that specific language can filter that out because it just sounds like noise to them. In the case of CDMA it's not a language, it's a sequence of 1's and 0's, called a code, and each of the codes is unique to a conversation so that they can be kept separate.” (Tr. (Nettleton) at 503:22-504:14.).

Figure 22: Respondents' Depiction of Padovani Disclosing the Measuring Limitations

'587 Patent Claim 4

4. A communication terminal apparatus comprising:
a measuring device that measures reception quality of a pilot signal to output information having a plurality of bits that indicate the measured reception quality;
a coding device that encodes the information to obtain a code word; and
a transmitter that transmits the code word, wherein:
the coding device encodes the information such that the most significant bit of the plurality of bits is less susceptible to errors in a propagation path than other bits of the plurality of bits.

'590 Patent Claim 3

3. A communication terminal apparatus comprising:
a measurer that measures a downlink channel quality and outputs information that is generated in association with said downlink channel quality and composed of a plurality of digits including an upper digit and a lower digit
a coder that encodes the information such that the upper digit is assigned a larger number of bits than the lower digit; and
a transmitter that transmits the encoded information to a base station apparatus.

Padovani

forward and reverse link capacity in the data communication system. Upon receipt of the paging messages from one or more base stations, the mobile station measures the signal-to-noise-and-interference ratio (C/I) of the forward link signals (e.g. the forward link pilot signals) at every time slots and selects the best base station using a set of parameters which can comprise the present and previous C/I measurements. In the exemplary

RX-1618.7

list of base stations in communication with the mobile station. Specifically, the mobile station measures the signal-to-noise-and-interference ratio (C/I) of the forward link pilot from the base stations in the active set, as received at the mobile station. If the received pilot signal is above a predetermined

RX-1618.11

(RDX-0005C.0093 (introduced during the testimony of Steven Wicker)).

Padovani discloses the transmitting limitations of the asserted claims, as shown below in Figure 23. Padovani teaches a data request (or DRC) message that indicates “actual measurement of the quality of the downlink channel based on the reception of pilot signals.” (Tr. (Wicker) at 1547:7-22; *see also* Tr. (Nettleton) at 2446:19-2447:4; RDX-0005C.0095; RX-1618 (Padovani) at 12:6-9.). For example, Padovani explains:

The mobile station then identifies the best base station and transmits to the selected base station a data request message 5 (hereinafter referred to as the DRC message) on the data request channel (hereinafter referred to as the DRC channel). The DRC message can contain the requested data rate or, alternatively, an indication of the quality of the forward link channel (e.g., the C/I measurement itself, the bit-error-rate, or the packet-error-rate).

(RX-1618 (Padovani) at 10:3-9.).

Figure 23: Respondents’ Depiction of Padovani Disclosing the Transmitting Limitations

'587 Patent Claim 4

4. A communication terminal apparatus comprising:
 a measuring device that measures reception quality of a pilot signal to output information having a plurality of bits that indicate the measured reception quality;
 a coding device that encodes the information to obtain a code word; and
 a transmitter that transmits the code word, wherein:
 the coding device encodes the information such that the most significant bit of the plurality of bits is less susceptible to errors in a propagation path than other bits of the plurality of bits.

'590 Patent Claim 3

3. A communication terminal apparatus comprising:
 a measurer that measures a downlink channel quality and outputs information that is generated in association with said downlink channel quality and composed of a plurality of digits including an upper digit and a lower digit;
 a coder that encodes the information such that the upper digit is assigned a larger number of bits than the lower digit; and
 a transmitter that transmits the encoded information to a base station apparatus.

on the largest C/I measurement. The mobile station then identifies the best base station and transmits to the selected base station a data request message (hereinafter referred to as the DRC message) on the data request channel (hereinafter referred to as the DRC channel). The DRC message can contain the requested data rate or, alternatively, an indication of the quality of the forward link channel (e.g., the C/I measurement itself, the bit-error-rate, or the packet-error-rate). In the exemplary embodiment, the mobile station can

RX-1618.12

The exemplary block diagram of the pilot/DRC channel is shown in FIG. 6. The DRC message is provided to DRC encoder 626 which encodes the message in accordance with a predetermined coding format. Coding of the

RX-1618.47

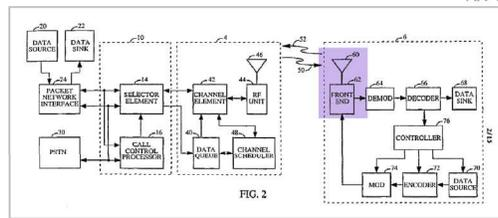

RX-1618.60

(RDX-0005C.0098 (introduced during the testimony of Dr. Wicker)).

Padovani discloses encoding a data rate control (DRC) message, as shown below in Figure 24. For example, Padovani explains that the “DRC message is provided to [a] DRC encoder 626 which encodes the message in accordance with a predetermined coding format.” (RX-1618 (Padovani) at 47:16-17; Tr. (Wicker) at 1544:9-18.). Both experts, Dr. Nettleton and Dr. Wicker, agreed that the coding of the DRC message is “important since the error probability of the DRC message needs to be sufficiently low because incorrect forward link data rate determination impacts the system throughput performance.” (RX-1618 (Padovani) at 47:17–20; Tr. (Nettleton) at 2448:15-21; Tr. (Wicker) at 1549:3-10.).

combine their obviousness analysis of Padovani with three secondary references that purportedly feature unequal encoding. (RBr. at 7 (“the only aspect of the “coding device” / “coder” limitation that Padovani does not expressly disclose is that the encoding scheme used to encode the DRC message is an unequal one”).).

The analyses that follow focus on the presence or absence of such unequal encoding in the prior art combinations that Respondents identified. The analyses also explain whether a person of ordinary skill in the art would have had the motivation to make, and a reasonable expectation of success in making, Respondents’ proposed prior art combinations in order to invalidate the ’587 and ’590 patents. Ultimately, Respondents’ prior art, whether alone or in combination, do not succeed.

4. The Asserted Claims Are Not Obvious Over Padovani and Seshadri

Seshadri was published on November 2, 1995, and is prior art under pre-AIA 35 U.S.C. § 102(b). (RX-1635 (Seshadri) at Cover.). Seshadri discloses two portions of data “having differing levels [of] significance relative to each other.” (*Id.* at [0010]; Tr. (Wicker) at 1549:22-1550:13.). As shown below in Figure 25, Seshadri applies varying error protection to these portions to improve system capacity and signal quality. (RX-1635 (Seshadri) at [0010], Fig. 6; Tr. (Wicker) at 1549:22-1550:13.).

Figure 25: Respondents' Comparison of the Unequal Encoding Schemes Taught in the '587/'590 Patents (left) and Seshadri (right)

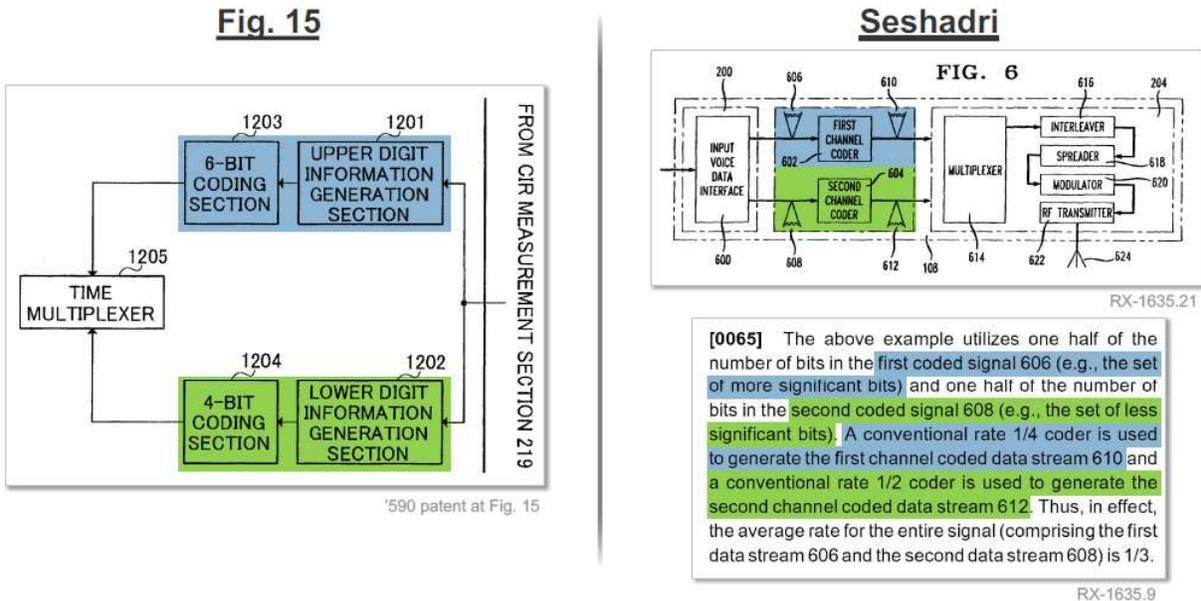

(RDX-0005C.0103 (introduced during the testimony of Dr. Wicker).).

Figure 6 of Seshadri shows data separated into two streams, each of which is “a series of bits.” (Tr. (Nettleton) at 2451:12-2452:1; RX-1635 (Seshadri) at Fig. 6.). As Dr. Nettleton explained, “the most significant bits are sent to the first channel encoder.” (Tr. (Nettleton) at 2452:2-5.). The “least significant bits are sent to the second channel encoder 604.” (*Id.* at 2452:6-9.). The first channel coder outputs four bits for every one bit encoded, while the second channel coder outputs only two bits for every one bit encoded. (*Id.* at 2452:10-23; Tr. (Wicker) at 1550:20-1551:24; RX-1635 (Seshadri) at 9, 21.). Thus, Seshadri teaches unequal error protection of the type claimed in the '587 and '590 patents. That is, Seshadri teaches for purposes of encoding, the mathematical sequestration or separation of a most significant bit (MSB) from the remaining bits. In other words, the encoding of each stream in Seshadri is separate, not blended.

Public Version

However, Respondents' combination of Padovani and Seshadri is contrary to settled law with respect to obviousness. As discussed below, the '587 and '590 patents and Padovani, and Seshadri do not address the same problem. *See Innovention Toys, LLC v. MGA Entertainment, Inc.*, 637 F.3d 1314, 1321 (Fed. Cir. 2011) (if a reference does not relate to the same problem as the problem faced by the inventor, the reference is not proper). Similarly, the '587 and '590 patents and Padovani, on the one hand, and Seshadri, on the other hand, are not analogous art. *See In re Bigio*, 381 F.3d 1320, 1325, 72 USPQ2d 1209, 1212 (Fed. Cir. 2004) (A prior art reference must be analogous art to the claimed invention.).).

As Dr. Wicker explained, Padovani discloses using a rate (8,4) cyclic redundancy check ("CRC")⁵⁰ block encoder to encode a DRC message. (RX-1618 (Padovani) at 47:20-22; Tr. (Wicker) at 1545:9-12.). By contrast, Dr. Nettleton testified that Seshadri discloses a voice data encoder (or vocoder). (Tr. (Nettleton) at 2427:15-2428:14.). Dr. Nettleton explained that the "output of a vocoder is a continuous stream of data representing user data, whereas DRC or anything like it is a very short control message." (Tr. (Nettleton) 2428:11-14.). Moreover, speech encoding is an "arcane area" and a "specialized discipline." (*Id.* at 2426:23-2427:5.). Dr. Nettleton was clear about this disconnect: "there's no nexus between them. I don't understand why anyone trying to solve the block coding problem would turn to voice coding for a solution." (*Id.* at 2428:15-21.).

In rebuttal, Respondents demonstrated at least a tenuous technological nexus between Padovani and Seshadri. Seshadri and Padovani each seek, broadly, to improve the same 2G cellular IS-95 standard. (Tr. (Nettleton) at 2453:14-25 (confirming that Seshadri and Padovani is

⁵⁰ CRC is a "means of detecting errors," but "does not correct errors" or "provide unequal error protection." (Tr. (Nettleton) at 2422:24-2423:4.).

Public Version

directed to spread spectrum communication systems), 2454:1-4, 2455:7-10.). Seshardi and Padovani are directed, again broadly, to improving the efficiency of a CDMA system. (Tr. (Nettleton) at 2455:11-2456:10; RX-1618 (Padovani) at 7 (“The present invention improves the efficiency of a CDMA system”); RX-1635 (Seshadri) at 4 (the present invention “utilizes channel bandwidth in a more efficient manner” and “affords greater system capacity”).). Seshadri even cites a paper written by Padovani. (Tr. (Nettleton) at 2456:24-2457:4; RX-1635 (Seshadri) at 1.).

However, such a “broad strokes” comparisons or combination of two (2) pieces of prior art is not sufficiently specific to suggest obviousness over the Asserted Claims. Respondents have failed to prove by clear and convincing evidence that the technological nexus between Padovani and Seshadri is strong enough for a person of ordinary skill in the art to be motivated to combine them to achieve the unequal DRC encoding scheme found in the asserted claims.

Dr. Nettleton presented compelling reasons why the combination is problematic. In response, based on Padovani’s disclosure that encoding the DRC message is “important,” Dr. Wicker opined that a person of ordinary skill in the art would have been motivated to consider other well-known error control techniques suitable for encoding a DRC message that ensured low error probability without requiring substantial additional bandwidth. (Tr. (Wicker) at 1552:12-20.). Yet, Dr. Wicker undermined his own argument by admitting that Seshadri does not “refer to CQI [or DRC] values” and “refers more generally to values where some bits are more important than other bits.” (*Id.* at 1640:4-9.). Also, in reference to Padovani, Dr. Wicker appears to have engaged in impermissible hindsight or, at the very least, casual speculation and inference. He explained: a person of ordinary skill in the art “would have looked and said, well, it looks like some of these data bits [in Padovani] are more important than others.” (Tr. (Wicker)

at 1554:11-13); *see In re NTP, Inc.*, 654 F.3d 1279, 1299 (Fed. Cir. 2011) (the patent-in-suit may not be used “as a guide through the maze of prior art references, combining the right references in the right way so as to achieve the result of the claims in suit.”).

It is a finding here that, while Seshadri teaches unequal error protection of the type claimed in the '587 and '590 patents, Respondents have failed to prove by clear and convincing evidence that a person of ordinary skill in the art had the motivation to combine Padovani and Seshadri.

5. The Asserted Claims Are Not Obvious Over Padovani and Jarvinen

Jarvinen was filed on February 6, 1998 and is prior art under pre-AIA 35 U.S.C. § 102(e). (RX-1640 (Jarvinen) at Cover.). Jarvinen teaches a “focused error correction method for use with speech parameter bits” within a cellular communication system. (*Id.* at Abstract.). As shown below in Figure 26, Jarvinen recognized that the most significant bits “are more important and they must be protected carefully.” (*Id.* at 3:53-57.). To this end, Jarvinen “minimize[s] the effect of data transfer errors” by dividing speech parameter bits into two categories (a “first part” and a “second part”) and applying error control coding only to the most important bits. (*Id.* at 3:35–39, 5:8–29, 5:40–64, Fig. 1C.).

Dr. Wicker testified that Jarvinen explains that the most important speech parameter bits are encoded for error protection, while the least important bits do not receive error protection encoding. (Tr. (Wicker) at 1560:9-1562:9; RX-1640 (Jarvinen) at 2:67-3:18, 7:52–63 (“Speech signal 100 is coded in speech encoder 101 into speech parameters 102, which are further transferred to channel encoder 104. Channel encoder 104 adds the error correction and error detection bits in connection with speech parameters 102.”), 10:30-50.). Jarvinen varies the number of speech parameter bits subject to encoding, and thus protection, based on the quality of

the data connection. (RX-1640 (Jarvinen) at 3:14-18.).

Figure 26: Respondents' Depiction of Jarvinen's Encoding Scheme in View of Padovani

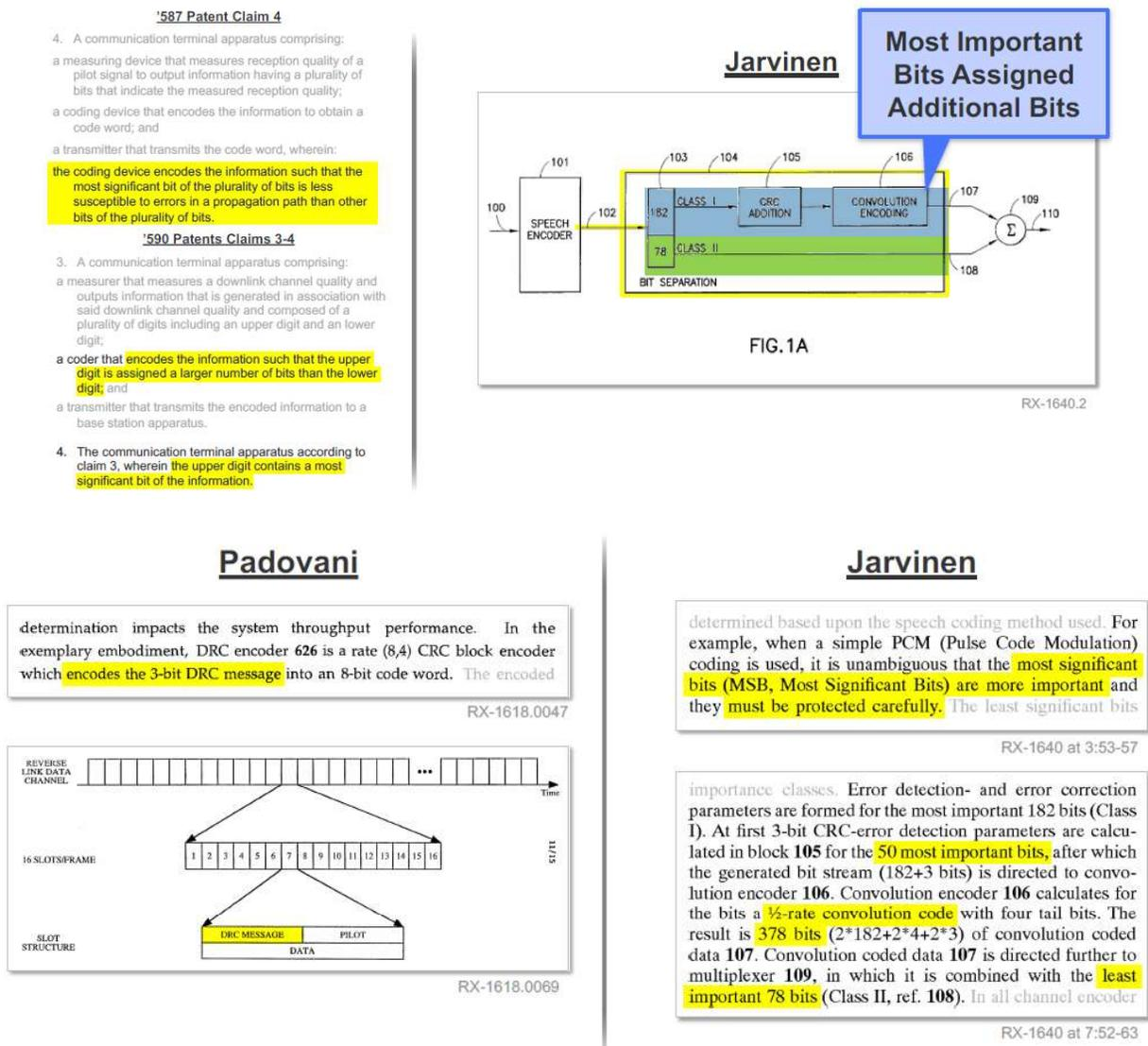

(RDX-0005C.0113-14 (introduced during the testimony of Dr. Wicker).).

As was the case with the Padovani (DRC message) and the Seshadri (speech encoding) combination, here Respondents have not presented clear and convincing evidence of obviousness. Like Seshadri, Jarvinen pertains to speech encoding and, on that ground alone, fails to constitute analogous art, or address the same problem, as compared to Padovani and the

'587/'590 patents, for the reasons set forth above.

Unlike Padovani, Jarvinen does not tie error protection to DRC messages or channel quality information.⁵¹ (Tr. (Nettleton) at 2423:25-2424:7, 2429:14-21; Tr. (Wicker) at 1638:4-12 (Padovani), 1641:19-24 (Jarvinen) (agreeing with Dr. Nettleton on this point).). Moreover, according to Dr. Nettleton, a person of ordinary skill in the art with the “simple task of encoding a short block of information” would not have looked to voice coding techniques, such as those described in Jarvinen. (Tr. (Nettleton) at 2427:2-5, 2430:2-11.). Dr. Nettleton explained that the “output of a vocoder is a continuous stream of data representing user data, whereas DRC or anything like it is a very short control message.” (*Id.* at 2428:11-14.). Dr. Nettleton also testified that speech encoding is an “arcane area” and a “specialized discipline.” (*Id.* at 2426:23-2427:5.).

Jarvinen’s incompatibility with Padovani is not remedied by the aspirational, boilerplate language that Respondents cited with respect to the scope of Jarvinen’s teachings: “[n]othing however limits using the information coding system according to the invention for coding of data other than speech data.” (RX-1640 (Jarvinen) at 2:53–55; RBr. at 10.). Respondents’ implication is that Jarvinen’s encoding techniques could be applied in the context of DRC

⁵¹ Jarvinen appears to teach a singular, not differential, error protection encoding technique, whereby one set of bits gets error protection while the remaining bits get no protection. (RX-1640 (Jarvinen) at 7:52-63 (“Channel encoder 104 adds the error correction- and error detection bits in connection with speech parameters 102. In bit separation block 103 the speech parameters are divided into two importance classes. Error detection- and error correction parameters are formed for the most important 182 bits (Class I). At first 3-bit CRC-error detection parameters are calculated in block 105 for the 50 most important bits, after which the generated bit stream (182+3 bits) is directed to convolution encoder 106. Convolution encoder 106 calculates for the bits a ½-rate convolution code with four tail bits. The result is 378 bits (2*182+2*4+2*3) of convolution coded data 107. Convolution coded data 107 is directed further to multiplexer 109, in which it is combined with the least important 78 bits (Class II, ref. 108). In all channel encoder 104 produces to the output (ref. 110) 456 bits for each 20 ms speech frame, so that the total line speed of the FR-speech codec in the GSM-system comes to 22.8 kbps.”).).

messages. However, “obviousness concerns whether a skilled artisan not only could have made but would have been motivated to make the combinations or modifications of prior art to arrive at the claimed invention.” *Belden Inc. v. Berk-Tek LLC*, 805 F.3d 1064, 1073 (Fed. Cir. 2015). Here, for the reasons set forth above, Respondents have failed to prove by clear and convincing evidence that a person of ordinary skill in the art had the motivation to make, and a reasonable expectation of success in making, the Padovani and Jarvinen combination. Simply put, these references are too different from one another.

6. The Asserted Claims Are Not Obvious Over Padovani and Marshall

Marshall is prior art under pre-AIA § 102(b). (RX-1630 (Marshall) at Cover (published on March 26, 1996).). Marshall teaches a system for transmitting voice data parameter values. (Tr. (Nettleton) at 2424:24-2425:2, 2426:13-15; RX-1630 (Marshall) at Abstract, 1:3-6.). Marshall splits “most significant bits and less significant bits” and “encod[es]” the most significant bits with a robust signaling alphabet and “encod[es]” the less significant bits with less robust signaling alphabets. (RX-1630 (Marshall) at Abstract; Tr. (Wicker) at 1555:10-1556:2.).

For example, Marshall discloses using two 2-state symbols for the two most important bits and using one 4-state symbol for the two least significant bits. (Tr. (Wicker) at 1556:5-1557:2, 1559:1-15; RDX-0005C.0106, 109; RX-1630 (Marshall) at 2:41-56.). As shown below in Figure 27, the most significant bit is “fed to a bi-level modulation device” (in blue) and the least significant bit is “fed to a four-level modulation device” (in green). (RX-1630 (Marshall) at 3:51-55, 3:60-63; Tr. (Wicker) at 1559:1-15; RDX-0005C.0109.). The bi-level modulation device outputs more symbols than the four-level device. (Tr. (Wicker) at 1559:1-15.). More symbols translate into more error protection. (RX-1630 (Marshall) at 1:38-56.).

Figure 27: Respondents' Comparison of the Unequal Encoding Schemes Taught in the '587/'590 Patents (left) and Jarvinen (right)

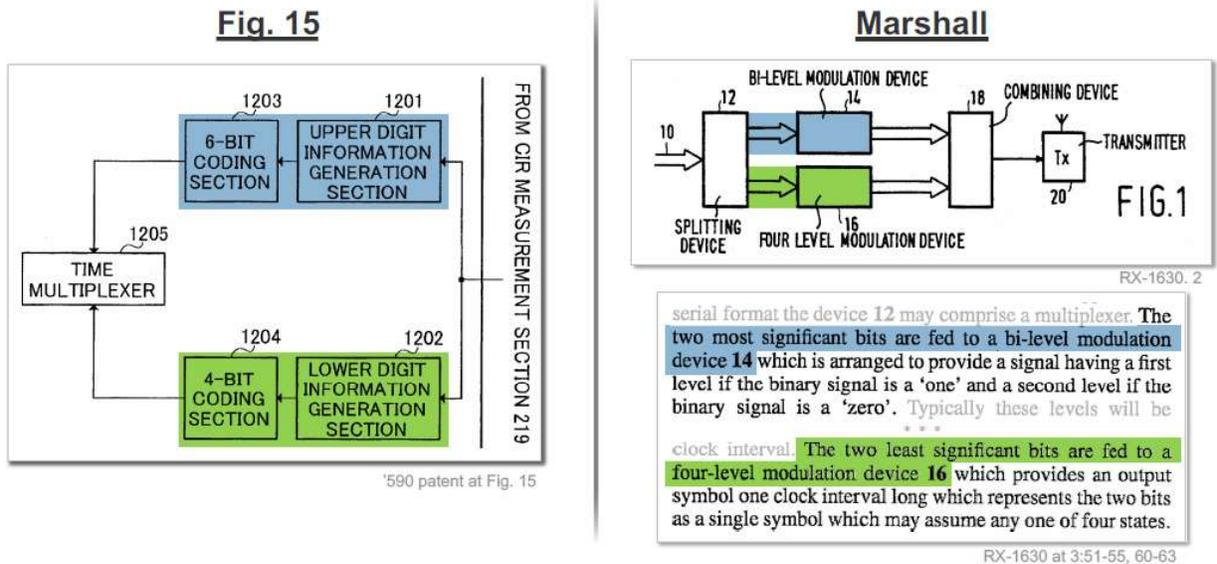

(RDX-0005C.0109 (introduced during the testimony of Dr. Wicker).).

Marshall clearly discloses an input data flow split into two streams, each of which is sent to a different modulation device. (RX-1630 (Marshall) at Fig. 1; Tr. (Wicker) at 1559:1-15; RDX-0005C.0109.). Marshall also clearly discloses modulating the respective streams to achieve a “reduction in [the most significant bit’s] susceptibility to error.” (RX-1630 (Marshall) at 2:44-47; Tr. (Wicker) at 1558:9-21; RDX-0005C.0108.).

However, Dr. Nettleton explained that modulation is how information is imprinted onto a radio frequency carrier, while the '587 and '590 patents involve a different type of “encoding,” that is the manipulation of bits to correct errors at the receiver. (Tr. (Nettleton) at 2425:15-2426:2.). Marshall is also primarily concerned with speech data and does not explicitly disclose transmission of the claimed channel quality “information.” (Tr. (Nettleton) 2426:18-2427:5.). Marshall does contain language suggesting a broader application of its teachings: “the present invention relates . . . to the communication of parameter values in a noisy environment.” (RX-

Public Version

1630 (Marshall) at 1:3-6.). However, this language is open-ended and fails to point a person of ordinary skill in the art to a technological combination with channel quality information generally, or to the Padovani reference specifically.

Marshall also discloses, in passing at the very end of the specification, encoding the most significant bit with a code that provides “two output bits for each input bit.” (RX-1630 (Marshall) at 10:35-44; Tr. (Wicker) at 1557:6-1558:8.). The full paragraph cited previously reads as follows:

As an alternative to non-coincident symbol durations and clock intervals, the communication time saved by the invention may be used to *apply error correction or detection codes to the more significant bits of the digital word*. One suitable code would be *a convolutional code* which provides two output bits for each input bit. Other coding techniques, such as Hamming Codes may be applied. Error detection or correction coding bits for those more significant bits, which are probably communicated as two-state symbols, may be arranged to be communicated with the less significant bits as part of a multi-state symbol.

(RX-1630 (Marshall) at 10:35-45 (emphasis added).).

Yet, this passing reference to error protection by bit-based encoding, as opposed to modulation, is not clear and convincing. The passage mentions encoding only “the more significant bits” and remains silent on encoding other bits, such as less significant bits. The asserted claims require an encoding of both. (JX-0001 (’590 Patent), cls. 3-4; JX-0002 (’587 Patent), cl. 4.). Moreover, Dr. Nettleton provided unrebutted testimony that “[c]onvolutional codes [used in Marshall] are suitable mainly for continuous streams of data,” implying that their use for channel quality information is suspect. (Tr. (Nettleton) at 2458:10-11.).

Respondents have failed to present clear and convincing evidence that the asserted claims are obvious in light of Padovani in combination with Marshall. It is doubtful whether the ’587 and ’590 patents and Padovani, on the one hand, and Marshall, on the other hand, are analogous

Public Version

art given the former's focus on error protection through encoding bits and the latter's on error protection through modulation. *See In re Bigio*, 81 F.3d at 1325. There is also, at best, only a faint motivation to combine Marshall (speech encoding) and Padovani (DRC message) for many of the same reasons stated above with respect to the Jarvinen and Seshadri references, which also pertain to speech encoding. (*See* Tr. (Nettleton) 2426:16-2427:10 ("I don't understand how someone with the simple task of encoding a short block of information would turn to an arcane area like voice coding to try and find an answer.")). In rebuttal to Dr. Nettleton's specific reasoning for why Marshall and Padovani are not combinable, Dr. Wicker's general statement, that a person of ordinary skill in the art would have been motivated to consider other well-known error control techniques suitable for encoding a DRC message, is unavailing and certainly does not constitute clear and convincing evidence. (Tr. (Wicker) at 1553:13-1554:15, 1559:20-21.).

7. INVT Failed to Prove a Secondary Consideration of Non-Obviousness

INVT's sole secondary consideration⁵² of non-obviousness raised in its post-hearing briefing is based upon supposed industry adoption of the error protection approach taught by the '587 and '590 patents. (CRBr. at 14-15; CX-0470.). The existence of secondary considerations of non-obviousness does not control the obviousness determination; a court must consider "the totality of the evidence" before reaching a decision on obviousness. *Richardson-Vicks*, 122 F.3d at 1483. "Relevant secondary considerations include commercial success, long-felt but unsolved needs, failure of others, and unexpected results." *Allergan, Inc. v. Sandoz Inc.*, 726 F.3d 1286,

⁵² In its Pre-Hearing Brief, INVT asserted four (4) secondary considerations of non-obviousness of the asserted claims. (CPBr. at 57.). However, INVT did not discuss three (3) of its secondary considerations during the Hearing, in its Post-Hearing Brief, or in its Post-Hearing Reply Brief. Thus, INVT has waived argument on these three (3) additional theories (which are commercial success, lack of contemporaneous and independent invention by others, and the Samsung license). (CPBr. at 57.). INVT has waived these three secondary considerations pursuant to Ground Rule 10.1

Public Version

1291 (Fed. Cir. 2013) (citing *KSR Int'l Co. v. Teleflex Inc.*, 550 U.S. 389, 399 (2007)).

According to INVT, the supposed industry adoption occurred (as discussed in the infringement section above) by way of a 2008 ETSI submission by Panasonic, which led to the incorporation into the LTE standard of the error protection approach taught by the '587/'590 patents. (CRBr. at 6 n.2, 14-15; Tr. (Nettleton) at 2437:21-2438:2; CX-0470.). INVT argued:

Panasonic submitted a proposal to ETSI, in relation to the LTE standard, suggesting to move the all "1's" column so that it applied to the MSB. The creators of the LTE standard adopted Panasonic's proposal, changing the way CQI was encoded in LTE so that the most significant bit of the CQI was encoded using the all "1's" column.

(CRBr. at 14-15.).

INVT's industry adoption argument, below, is premised on an argument, rejected in Section VII.A on infringement, that simply moving the all "1's" column so that it applied to the MSB, and thus provided more error protection for the MSB, is all that is needed to practice the error protection approach that the '587 and '590 patents teach.

That is why, as Respondents agreed, INVT's secondary consideration argument is unavailing. (RBr. at 31-34 (all "1s" column had been included in standards long before the '587 and '590 patents); *see also* SBr. at 54-55 (opting not to address directly INVT's industry adoption argument).). INVT has failed to tie its purported indicia of non-obviousness to the asserted claims of the patents in suit. *Ormco Corp. v. Align Tech., Inc.*, 463 F.3d 1299, 1311-12 (Fed. Cir. 2006) ("Evidence of commercial success ... is only significant if there is a nexus between the claimed invention and the commercial success."); *In re GPAC Inc.*, 57 F.3d 1573, 1580 (Fed. Cir. 1995) ("For objective evidence to be accorded substantial weight, its proponent must establish a nexus between the evidence and the merits of the claimed invention.").

As discussed in Section VII.B on infringement, while the all "1s" column appears to be

Public Version

one way to enhance error protection for the MSB of channel quality information, the '587 and '590 patents taught a different way of achieving such error protection. The '587 and '590 patents taught separate error protection encodings of MSBs and less significant bits, such that the former could enjoy more code word minimum distance, and thus more error protection, than the latter.

In short, the '587 and '590 patents teach that these encodings are mathematically separate. By contrast, as shown below in Figure 28, Panasonic's 2008 ETSI was based upon an LTE encoding matrix that did not perform mathematically separate encodings of MSBs and less significant bits. (CX-0470 (Panasonic's 2008 ETSI Submission) at 1.). Thus, while industry adoption of the all "1s" column for the MSB in the LTE standard may have been an endorsement for the merits of that approach, it was not an endorsement, or evidence for non-obviousness, of the distinct error protection scheme that is specifically taught in the '587 and '590 patents. Consequently, INVT has not successfully proven a secondary consideration of non-obviousness.

Figure 28: Encoding Matrix Displayed in Panasonic’s 2008 ETSI Submission

Table 1. Basis sequences for (20,k) PUCCH CQI coding for LTE

i	M _{i,0}	M _{i,1}	M _{i,2}	M _{i,3}	M _{i,4}	M _{i,5}	M _{i,6}	M _{i,7}	M _{i,8}	M _{i,9}	M _{i,10}	M _{i,11}	M _{i,12}	M _{i,13}
0	1	0	0	0	0	1	0	0	0	0	1	1	0	0
1	1	1	0	0	0	1	0	0	0	1	1	1	0	0
2	0	0	1	0	0	1	1	0	1	1	1	1	1	1
3	0	1	1	0	0	1	0	0	1	0	1	1	1	1
4	1	1	1	0	0	1	0	1	0	0	1	1	1	1
5	1	0	0	1	0	1	1	1	1	0	1	1	1	0
6	0	1	0	1	0	1	1	0	1	1	1	1	1	0
7	0	0	1	1	0	1	0	1	1	0	1	1	1	1
8	1	0	1	1	0	1	0	1	0	1	1	1	1	1
9	0	1	1	1	0	1	1	0	0	1	1	1	1	1
10	0	1	0	0	1	1	1	1	0	1	1	1	1	1
11	1	1	0	0	1	1	1	0	1	0	1	1	1	1
12	0	0	1	0	1	1	0	1	1	1	1	1	1	1
13	1	0	1	0	1	1	0	1	0	1	1	1	1	1
14	0	0	0	1	1	1	0	1	0	0	1	0	1	1
15	1	0	0	1	1	1	1	1	0	1	1	0	1	1
16	1	1	0	1	1	1	1	0	0	1	0	1	1	1
17	0	0	1	1	1	1	0	0	1	0	0	1	1	1
18	1	0	1	1	1	1	1	1	0	0	0	0	0	1
19	0	0	0	0	1	1	1	0	0	0	0	0	0	1

(CX-0470 (Panasonic’s 2008 ETSI Submission) at 1.).

Nevertheless, INVT’s lack of evidence of secondary considerations of non-obviousness is just one factor to consider and does not alter the outcome of the obviousness analysis herein. *See Richardson-Vicks*, 122 F.3d at 1483 (a court must consider “the totality of the evidence” before reaching a decision on obviousness). For the reasons set forth above (i.e. differences between the asserted claims and the prior art as viewed by a person of ordinary skill in the art), Respondents have not proven by clear and convincing evidence that the asserted claims of the ’587 and ’590 patents are obvious in light of Respondents’ prior art combinations.

8. Respondents’ Argument That the Combination of AAPA and TS 25.212 V3.2.0 Render the Asserted Claims Obvious Is Not Supported

Respondents argued in the alternative that AAPA and TS 25.212 V3.2.0 invalidate

Public Version

the '587 and '590 patents. AAPA is prior art discussed in the shared specification of the '587/'590 patents, particularly the "Background Art" section. (RBr. at 18.).

TS 25.212 V3.2.0 (RX-1606) is a 3GPP technical specification related to the R99 release of the 3G standard, or the release that occurred before the 3G standard at issue in this case. (See RBr. at 1 (citing to RX-1606.)). TS 25.212 V3.2.0 is entitled "Multiplexing and channel coding (FDD)," and describes how physical layer data streams are encoded or decoded to go to or from MAC layers in an R99 system. (RX-1606; RBr. at 19.). TS 25.212 V3.2.0 was published in March 2000 and is prior art under 35 U.S.C. § 102(a). (Tr. (Wicker) at 1533:8-1534:3; Tr. (Nettleton) at 2462:7-12.).

Respondents' combination of AAPA and TS 25.212 V3.2.0 fails for lack of a required predicate, namely a finding that the 3G and LTE standards satisfy the "encoding the information" limitations of the '587/'590 patents. Staff agreed. (SBr. at 53-54 ("TS 25.212 V3.2.0 does not disclose the claimed encoder/coding device of the patents for reasons similar to those presented as to why the asserted '590/'587 patents are not essential to the asserted standards"). Respondents acknowledge that its AAPA and TS 25.212 V3.2.0 combination succeeds only if the "encodes the information" limitation of the asserted claims were interpreted to cover the encoding matrices of the 3G and LTE standards. (RBr. at 18 ("although Respondents have conclusively proven that the coding scheme in the 3G and LTE standards does not infringe, to the extent the ALJ finds otherwise, the equivalent scheme in TS 25.212 V3.2.0 renders the claims invalid").). Contrary to Respondents' conditional argument, the "encodes the information" limitations were interpreted and applied, in conformance with the *Markman* Order, such that they explicitly do not cover the 3G and LTE standards.

Thus, with respect to whether the combination of AAPA and TS 25.212 V3.2.0 renders

the asserted claims obvious, Respondents' arguments are denied as lacking a required predicate (i.e., a finding that the 3G and LTE standards practice the asserted claims).

9. Respondents' Written Description Argument Is Unavailing

Respondents argued (also conditionally) that the '587 and '590 patents are invalid under 35 U.S.C. § 112 for lack of written description. Patents are presumed valid. 35 U.S.C. § 282. The first paragraph of Section 112 says: "The specification shall contain a written description of the invention, and of the manner and process of making and using it, in such full, clear, concise, and exact terms as to enable any person skilled in the art to which it pertains, or with which it is most nearly connected, to make and use the same. . . ." 35 U.S.C. § 112.

To comply, a patent applicant must "convey with reasonable clarity to those skilled in the art that, as of the filing date sought, he or she was in possession of the [claimed] invention." *Vas-Cath Inc. v. Mahurkar*, 935 F.2d 1555, 1563-64 (Fed. Cir. 1991) (emphasis omitted). "The form and presentation of the description can vary with the nature of the invention[.]" *In re Skvorecz*, 580 F.3d 1262, 1269 (Fed. Cir. 2009). "[T]he applicant [for a patent] may employ 'such descriptive means as words, structures, figures, diagrams, formulas, etc., that fully set forth the claimed invention.'" *Id.* (citing *In re Alton*, 76 F.3d 1168, 1172 (Fed. Cir. 1996)). The adequacy of the description depends on content, rather than length. *In re Hayes Microcomputer Prods., Inc. Patent Litig.*, 982 F.2d 1527, 1534 (Fed. Cir. 1992). "Specifically, the level of detail required to satisfy the written description requirement varies depending on the nature and scope of the claims and on the complexity and predictability of the relevant technology." *Ariad Pharms., Inc. v. Eli Lilly & Co.*, 598 F.3d 1336, 1352 (Fed. Cir. 2010) (en banc).

Compliance with the written description requirement is a question of fact. In order to overcome the presumption of validity, a party must set forth clear and convincing evidence.

Public Version

Centocor Ortho Biotech, Inc. v. Abbott Labs., 636 F.3d 1341, 1347 (Fed. Cir. 2011). The Federal Circuit also has held with respect to the written description requirement that “[a] claim will not be invalidated on section 112 grounds simply because the embodiments of the specification do not contain examples explicitly covering the full scope of the claim language.” *Falko-Gunter Falkner v. Inglis*, 448 F.3d 1357, 1366 (Fed. Cir. 2006) (quoting *LizardTech, Inc. v. Earth Resource Mapping, PTY, Inc.*, 424 F.3d 1336, 1345 (Fed. Cir. 2005)).

Respondents’ written description argument applies only in the alternative and only if the “encodes the information” limitation of the asserted claims were interpreted to cover the encoding matrices of the 3G and LTE standards. (RBr. at 35.). Respondents said so in their Initial Post-Hearing Brief:

INVT and Dr. Nettleton, however, are attempting to read this claim element on the Reed-Muller encoding process in 3G and LTE systems. This type of encoding process is not described anywhere in the ’587 patent. ... In fact, there is no indication that the inventors possessed any other technique of encoding information to render it less susceptible to error besides that disclosed in Figure 15, and certainly no indication that the inventors possessed all techniques of encoding information to render it less susceptible to error. ... *To the extent the claims are interpreted broadly enough to cover the functionality accused of infringement by INVT, the claims are not supported by the written description.*

(*Id.* (emphasis added).).

The “encodes the information” limitations were interpreted and applied, in conformance with the *Markman* Order, such that they remained squarely within the four corners of the shared specification of the ’587 and ’590 patents. The limitations as construed explicitly did not cover the 3G and LTE standards. *See* Section VII.A on infringement. Therefore, Respondents’ written description argument is denied as lacking a required predicate (i.e., a finding that the 3G and

LTE standards practice the asserted claims).⁵³

VIII. U.S. PATENT NO. 7,848,439

A. INVT Failed to Prove That Independent Claim 1 of the '439 Patent Is Essential to the LTE Standard

INVT asserted and argued that independent claim 1 and dependent claim 2 of the '439 patent are essential to the LTE standard and infringed. (CBr. at 90.). Specifically, INVT alleged that the LTE standard requires all of the limitations recited in claims 1 and 2 of the '439 patent. (CBr. at 94.). For the following reasons, a preponderance of evidence does not support INVT's assertion and argument that claims 1 and 2 of the '439 patent are patent-essential.

As recited in independent claim 1 of the '439 patent, "a data obtaining section" in the communication apparatus "demodulates and decodes a received signal using the modulation parameters and the coding parameters decided at the parameter deciding section."⁵⁴ (JX-0003 at

⁵³ If the *Markman* Order had not interpreted "a coding device that ..." found in claim 4 of the '587 patent as a means-plus-function term limited to structure disclosed in the specification, that term would likely violate the written description requirement for the reasons provided in the *Markman* Order. (See *Markman* Order at 22-23.). In particular, removed from the context of the specification, the term covered any coding device that "encodes the information such that the most significant bit of the plurality of bits is less susceptible to errors in a propagation path than other bits of the plurality of bits." (JX-0002 ('587 patent), cl. 4). As the *Markman* Order explained, "[w]hat is missing with respect to the 'coding device' limitation is structural mooring with respect to how the encoding takes place 'such that the most significant bit of the plurality of bits is less susceptible to errors in a propagation path than other bits of the plurality of bits.' The term 'most significant bit' does not appear in the specification. The term 'less susceptible to errors in a propagation path' is open-ended and relative, not tied to structure." (*Id.* at 25.). Thus, if "coding device" were not limited to structure disclosed in the specification, INVT's attempt to read that limitation on the 3G and LTE standards (which appear to provide more error protection for the MSB, but not in any way contemplated by the shared specification of the '587/'590 patents or possessed by inventors of the '587/'590 patents) would likely amount to a violation of the written description requirement. See *LizardTech, Inc. v. Earth Res. Mapping, Inc.*, 424 F.3d 1336, 1344-45 (Fed. Cir. 2005) (claims directed to an image compression algorithm were invalid for lack an adequate written description where the specification described only one mode of performing the compression but the asserted claims generally claimed all modes that could compress the image).

⁵⁴ The "data obtaining section" resides within the communication apparatus, that is, the mobile device or user equipment. (See, e.g., Tr. (Vojcic) at 823:21-24.). When he testified during the Hearing on

Public Version

cl. 1.). Pursuant to Order No. 52,⁵⁵ the communication apparatus, e.g., mobile device or UE, can initially decide parameters, and the communicating party, e.g., base station, can make “a final or superseding decision that those *very parameters* are appropriate for a subsequent communication between the two entities.” (Order No. 52 at 3 (emphasis added)). INVT failed to present evidence that the modulation and coding parameters corresponding to the CQI⁵⁶ index the UE initially reports to the base station are the “very parameters” that the base station ultimately determines are appropriate. (*Id.* at 2.).

For example, Respondents’ expert, Dr. Acampora, explained that the CQI report indicates the “maximum rate at which the base station can send real data to the UE, expressed as a modulation scheme and a coding scheme.” (Tr. (Acampora) at 1874:13-1875:4.). He confirmed that the base station does not report back to the UE the modulation and coding parameters reported in the CQI report.

Q. . . . Does the LTE base station specify its selected modulation and coding scheme using the same parameters as reported in a CQI report?

A. No, the parameters reported in the CQI report are a modulation rate and a code rate. Those numbers are not reported back by the base station.

September 16, 2019, Dr. Branimir Vojcic was the President of Xplore Wireless LLC, a telecommunication consulting company and a co-founder, Director, CEO, and CTO of LN2, a startup in the telecommunication industry. (CPSSt. at 9; *see also id.* at Ex. B.).

⁵⁵ During an August 7, 2019 Telephone Conference, the Parties were asked to provide additional briefing with respect to Respondents’ Motion for Summary Determination of Non-Infringement and No Technical Domestic Industry of U.S. Patent No. 7,848,439. (Motion Docket No. 1138-024 (Apr. 9, 2019); Doc. ID No. 690692 at 27:8-11, 29:3-22, 30:8-17 (Teleconf. Tr.) (Oct. 8, 2019) (public).). The Parties filed the requested supplemental briefing. (Doc. ID No. 685125 (Aug. 13, 2019) (Complainant); Doc. ID No. 685201 (Aug. 13, 2019) (Staff); Doc. ID No. 685218 (Aug. 13, 2019) (Respondents).). Order No. 52 addresses the issues discussed in the Parties’ supplemental briefing.

⁵⁶ CQI is an acronym for “channel quality indicator.” (*See, e.g.,* CX-0068.0008 (3GPP TS 36.213 V8.4.0); RX-1520.0008 (same).).

Public Version

* * *

Two things are reported -- well, many things are reported back, but as far as the downlink assignment is concerned, the base station is reporting back a mobile -- an **MCS⁵⁷ Index**, Modulating and Coding Scheme Index, and it's reporting back the actual **resource blocks** that had been allocated that will use a common modulation and coding scheme.

(*Id.* at 1877:5-24 (emphases added).).

Dr. Acampora clarified that the MCS Index “directly identifies the modulation scheme that will be used,” and it directly identifies an index to a TBS⁵⁸ table, which he explained is “a measure of how much user information pre-coding is going to be delivered by the base station in the next transmission to the UE.” (*Id.* at 1877:25-1878:19.). Referring to the “Modulation and TBS Index table for PDSCH”⁵⁹ from one of the technical specifications of the LTE standard, Dr. Acampora noted that there are 32 values in the MCS Table. (*Id.* at 1880:2-4.).

⁵⁷ MCS is an acronym for “modulation and coding scheme.” (*See, e.g.*, CX-0068.0008 (3GPP TS 36.213 V8.4.0); RX-1520.0008 (same).).

⁵⁸ TBS is an acronym for “transport block size.” (Tr. (Acampora) at 1877:25-19.).

⁵⁹ PDSCH is an acronym for “physical downlink shared channel.” (*See, e.g.*, CX-0068.0008 (3GPP TS 36.213 V8.4.0); RX-1520.0008 (same).).

Table No. 9: Modulation and TBS Index

Table 7.1.7.1-1: Modulation and TBS index table for PDSCH

MCS Index I_{MCS}	Modulation Order Q_m	TBS Index I_{TBS}
0	2	0
1	2	1
2	2	2
3	2	3
4	2	4
5	2	5
6	2	6
7	2	7
8	2	8
9	2	9
10	4	9
11	4	10
12	4	11
13	4	12
14	4	13
15	4	14
16	4	15
17	6	15
18	6	16
19	6	17
20	6	18
21	6	19
22	6	20
23	6	21
24	6	22
25	6	23
26	6	24
27	6	25
28	6	26
29	2	reserved
30	4	
31	6	

(RX-1520.0023-24.).

Based on the MCS Index the UE receives, the UE will know the modulation rate and the TBS Index, that is which row of the TBS Table listed in pages 23-29 applies. (Tr. (Acampora) at 1881:9-13.). Once the UE learns the resource block assignment field corresponding to the correct row and column of the TBS Table, the UE is able to determine the code rate. (*Id.* at 1881:22-1882:3.). As Dr. Acampora pointed out, the TBS Table contains 110 columns and 27

Public Version

rows, which amounts to almost three thousand (3,000) values from which the base station chooses in order to compute the coding rate it ultimately decides to use. (*Id.* at 1881:14-21, 1882:12-14, 1883:18-24; RX-1520.0023-0029.). He explained that the reason for so many entries is “[t]o give the base station a great deal of flexibility in terms of the downlink assignment, including the assignment of the code rate to be used for all the resource blocks.” (Tr. (Acampora) at 1882:15-20.).

In contrast, the technical specifications of the LTE standard indicate that the CQI Table used to report CQI from the UE to the base station includes only sixteen (16) possible modulation and coding parameter combinations.

Table No. 10: CQI Table

Table 7.2.3-1: 4-bit CQI Table

CQI index	modulation	coding rate x 1024	efficiency
0	out of range		
1	QPSK	78	0.1523
2	QPSK	120	0.2344
3	QPSK	193	0.3770
4	QPSK	308	0.6016
5	QPSK	449	0.8770
6	QPSK	602	1.1758
7	16QAM	378	1.4766
8	16QAM	490	1.9141
9	16QAM	616	2.4063
10	64QAM	466	2.7305
11	64QAM	567	3.3223
12	64QAM	666	3.9023
13	64QAM	772	4.5234
14	64QAM	873	5.1152
15	64QAM	948	5.5547

(RX-1520.0043; *see also* RDX-0010.0021.).

Thus, as Dr. Acampora opined, even if the base station happens to consider the CQI reported by the UE, it does not appear to be likely, must less required, for the base station to choose the “very parameters” initially decided by the UE.

Public Version

Q. Now were you here when Dr. Vojcic suggested despite all the entries in this table only the 15 coding rates of the CQI table could be used?

A. I did hear him testify to that effect.

Q. Do you agree with that?

A. I do not agree with that.

Q. Why not?

A. The CQI table -- well, I already mentioned two reasons. The CQI table is uniquely identifying a modulation scheme and a coding scheme, but there will be - - well, there would be a number of such reports equal to the number of subbands. He didn't say anything about which one of those, if any, would be the one actually used. ***And from this table alone we see that there are almost 3,000 entries. There could be a large number of possible code rates, much larger than just 15 that were identified by any one CQI. So there are a large number of possible code rates that could be selected by the base station.***

Q. If there are only 15 possible code rates, would it make any sense to have a table with almost 3,000 entries?

A. No.

(Tr. (Acampora) at 1883:2-1884:3 (emphases added).).

Dr. Vojcic testified that this claim element is standard-essential because “all the accused products” are “***capable*** of receiving [and] demodulating and decoding using the parameters decided by the UE.” (Tr. (Vojcic) at 827:14-18 (emphasis added).). However, as Staff noted, patent essentiality cannot, as a matter of law, be established merely by showing that the asserted standard is capable of meeting the claim, as mere capability of a claimed feature is *ipso facto* not tantamount to the requirement that the claimed feature must be mandatory. *See, e.g., Optis Wireless Technology, LLC v. Huawei Techs. Co., Ltd.*, 2018 WL 3375192, at *1 (E.D. Tex. July 11, 2018) (noting that patent essentiality requires that the standard “necessarily” meets the elements of the claim, not that the standard is merely capable of meeting the elements of the claim).

Public Version

Moreover, Federal Circuit precedent establishes that “infringement is not proven *per se* by a finding that an accused product is merely capable of infringing because ‘in every infringement analysis, the language of the claims, as well as the nature of the accused product, dictates whether an infringement has occurred.’” See *Fantasy Sports Props., Inc. v. Sportsline.com, Inc.*, 287 F.3d 1108, 1117-18 (Fed. Cir. 2002) (clarifying when the capability test can apply); see also *Finjan, Inc. v. Secure Computing Corp.*, 626 F.3d 1197, 1204 (Fed. Cir. 2010) (noting that the “‘reasonably capable’ test applies only to claim language that specifies that the claim is drawn to capability”) (quoting *Ball Aerosol & Specialty Container, Inc. v. Ltd. Brands, Inc.*, 555 F.3d 984, 994 (Fed. Cir. 2009)).

Unlike the claims at issue in *Finjan* requiring mere capability (e.g., “a logical engine **for preventing** execution” and “a communications engine **for obtaining** a Downloadable”), the “receiving section” element of limitation [1d] recites “actual operation” (“a data obtaining section that demodulates and decodes . . . **using** the modulation parameters and the coding parameters **decided** at the parameter deciding section.”). *Finjan*, 626 F.3d at 1204-05 (emphases added); JX-0003 at cl. 1 (emphases added). Therefore, demonstrating mere capability in this instance does not equate to infringement. *Finjan*, 626 F.3d at 1204-05; JX-0003 at cl. 1.).

Relying upon the rejection of Respondents’ and Staff’s position that the mobile device must ‘us[e] the modulation parameters and the coding parameters decided at the parameter deciding section,’ and the ‘parameters decided by the parameter deciding section’ must be parameters that are finally decided by the claimed communication apparatus,” INVT also argued that requiring the UE and BS to **actually** use the same parameters contradicts Order No. 52. (CBr. at 103-04; Order No. 52 at 2.). Order No. 52 makes clear that what was rejected was Respondents and Staff’s view that claim 1 is “susceptive to only [that] **one** interpretation.”

Public Version

(Order No. 52 at 2 (emphasis added)). Although Order No. 52 did not provide an explicit construction of “using the modulation parameters and the coding parameters decided at the parameter deciding section,” Order No. 52 clarified that:

[I]t is possible to satisfy claim 1 of the '439 patent where a communication apparatus [mobile] “decides” on parameters and a communicating party [BS] makes a final or superseding decision that those very parameters are appropriate for a subsequent communication between the two entities. In that case, the communication apparatus [mobile] would decode the communication received from the communicating party [BS] based on the parameters initially “decided” on by the communication apparatus [mobile], and thus satisfy the claim limitation in dispute, even though the communicating party [BS], and not the communication apparatus [mobile], had the final or ultimate say in terms of selecting those parameters.”

(*Id.* at 3.).

Nothing in Order No. 52 supports INVT’s assertion that mere capability is sufficient. Claim 1 explicitly requires a “data obtaining section that demodulates and decodes . . . using the modulation parameters and the coding parameters decided at the *parameter deciding section*” of the UE. (JX-0003 at cl. 1 (emphasis added)). The quoted text (above) from Order No. 52 simply explains that claim 1 can be met in the additional instance where the BS agrees with the “very parameters” the UE has provided even though the BS, and not the UE, has made the final decision.

For the foregoing reasons, INVT failed to demonstrate that independent claim 1 of the '439 patent is standard-essential. Because dependent claim 2 depends from independent claim 1, INVT has also not established that claim 2 is essential to the standard for at least the same reasons discussed for claim 1.

Accordingly, INVT cannot simply rely on compliance with the asserted LTE standard to

establish infringement. *Optis Wireless*, 2018 WL 3375192, at *1.⁶⁰ Rather, INVT must present evidence proving that the actual operation of the 439 Accused Products meets every claim limitation of claims 1 and 2, which it failed to do for the reasons discussed below. *Id.*⁶¹

B. Infringement

1. Infringement Overview

Respondents did not contest that the 439 Accused Products practice the preamble and limitations [1b], [1c], and [1f] of claim 1 of the '439 patent. The crux of the dispute between the Parties is whether the 439 Accused Products contain the claimed “receiving section” and “data obtaining section” required by limitations [1d] and [1e] of claim 1 of the '439 patent.

Respondents also argued that INVT failed to meet its burden with respect to limitation [1a] because it did not establish that the 439 Accused Products perform a channel estimation for each LTE resource block, which INVT’s expert identified as corresponding to the claimed subband.

For the reasons discussed below, INVT has not shown that the 439 Accused Products include the features recited in limitations [1d] and [1e].

⁶⁰ “There are different ways of showing infringement of a standard essential patent. One could indirectly prove infringement by showing that (1) the standard necessarily meets the elements of the claim, (2) the accused product complies with the standard, and therefore (3) the accused product meets the claim. This indirect evidence approach may not require significant analysis of the accused product. However, it relies upon a necessary inference tying the product to the standard and the standard to the claim. The downside is that if the patent is not found to be essential to the standard, the link between the product and the patent breaks.” *Optis Wireless*, 2018 WL 3375192, at *1 (citing *Fujitsu Ltd. v. Netgear Inc.*, 620 F.3d 1321, 1327 (Fed. Cir. 2010)).

⁶¹ *Optis Wireless*, 2018 WL 3375192, at *1 (citing *Fujitsu* at 1327-28 (“We acknowledge, however, that in many instances, an industry standard does not provide the level of specificity required to establish that practicing that standard would always result in infringement. Or, as with the '952 patent, the relevant section of the standard is optional, and standards compliance alone would not establish that the accused infringer chooses to implement the optional section. In these instances, it is not sufficient for the patent owner to establish infringement by arguing that the product admittedly practices the standard, therefore it infringes. In these cases, the patent owner must compare the claims to the accused products or, if appropriate, prove that the accused products implement any relevant optional sections of the standard.”)).

2. INVT Failed to Prove That the Accused Products Practice Independent Claim 1 and Dependent Claim 2 of the '439 Patent

a) Independent Claim 1

i. [1Pre]: “A communication apparatus comprising”

The 439 Accused Products are communication terminal apparatuses because each is capable of communicating over 3G and LTE networks. (*See, e.g.*, CX-0554.0004 (iPhone 8); CX-0556.0005 (iPhone XS); CX-0121 (HTC U11); CX-0122.0004 (ZTE Max XL); RPBr. at 33-40; RRBr. at 41-57.).⁶²

In their Post-Hearing Reply Brief, Respondents did not contest that the 439 Accused Products meet the preamble of claim 1. (RRBr. at 41-57.). Thus, Respondents have waived any argument on this issue under Ground Rule 10.1.

Accordingly, INVT has proven by a preponderance of the evidence that the 439 Accused Products meet the preamble of claim 1 of the '439 patent.

ii. [1a]: “a channel estimating section that carries out a channel estimation per subband”

INVT alleged that the 439 Accused Products include the claimed “channel estimating section.” (CBr. at 112-15.). The Parties agreed that the term “per subband” means “for each subband.” (Joint CC Chart at 4; *Markman* Order at 37-38.).

Based on Dr. Vojcic’s opinion that the subbands of claim 1 correspond to LTE resource blocks, Respondents contended that INVT failed to carry its burden because it did not present any evidence that the LTE standard requires a mobile to perform a channel estimation for each

⁶² *See* Representative Product Stipulation. (Doc. ID No. 688512 (Sept. 18, 2019) (iPhone 8 and iPhone XS representative of the Apple Accused Products; HTC U11 representative of the Accused HTC Products; ZTE Max XL representative of the Accused ZTE Products).).

Public Version

resource block. (RRBr. at 56.). As discussed in Section VIII.A above, claim 1 was not found to be standard-essential. Thus, a lack of evidence establishing that the LTE standard necessitates such an estimation is irrelevant. For the following reasons, INVT presented compelling evidence that the 439 Accused Products practice limitation [1a].

Apple- [REDACTED] Based Products:

The Apple iPhone 8 incorporates a [REDACTED] LTE modem and an LTE transceiver. (CX-1236C.0013 (Resp. to Interrog. No. 3); Tr. (Vojcic) at 783:16-784:1.). The source code the [REDACTED] modem executes confirms that the iPhone 8 [REDACTED] [REDACTED] (See, e.g., Tr. (William Mangione-Smith)⁶³ at 954:19-955:5 ([REDACTED]), 955:6-18 ([REDACTED]); CPX-0053.).

As Dr. Mangione-Smith testified, the [REDACTED] [REDACTED]. (Tr. (Mangione-Smith) at 945:17-946:15; CPX-0053C; see also *id.* at 937:24-938:15 [REDACTED] [REDACTED], 945:1-948:6 [REDACTED] [REDACTED], 953:17-957:15 [REDACTED] [REDACTED].

⁶³ When he testified during the Hearing on September 16-17, 2019, Dr. William Mangione-Smith was the sole proprietor of Phase Two LLC. (CPSt. at Ex. C.). Dr. Mangione-Smith worked as an independent consultant in a wide range of technology areas related to innovation and intellectual property licensing. (CPSt. at 10.). Complainant identified Dr. Mangione-Smith as an expert to testify about matters relating to the design, structure, function, and operation, including the operation of source code, of the accused products and any article asserted to infringe the asserted patents. Additionally, Dr. Mangione-Smith was called to testify about the design, structure, function, and operation, including the operation of source code, of domestic industry products, and any research and development asserted to comprise Complainant's domestic industry. He was offered to testify with respect to issues in connection with infringement, the technical prong of the domestic industry requirement, and/or any other technical issue, and to rebut Respondents' expert or fact witness testimony. (*Id.* at 6-7.).

Public Version

[REDACTED]; CPX-0031C; CPX-0033C; CPX-0038C.).

Dr. Vojcic agreed with Dr. Mangione-Smith and explained that the functionality that Dr. Mangione-Smith identified confirms that “cell-specific reference signals are used to estimate channel conditions or to perform channel estimation” (Tr. (Vojcic) at 809:25-810:8). The

[REDACTED]

[REDACTED].⁶⁴ (Tr. (Mangione-Smith) at 993:9-996:11 [REDACTED]

[REDACTED]

[REDACTED]; CPX-0050 (Apple iPhone

8). Additionally, Apple’s corporate representative, Mr. Wei Zhang,⁶⁵ testified during his

deposition that the [REDACTED]. (CX-

1561C (Zhang Dep. Tr. (Jan. 18, 2019)) at 121:6-8 [REDACTED]

[REDACTED].).

Thus, the iPhone 8 satisfies the claimed “channel estimating section.”

Apple-Intel Based Products:

The Apple iPhone XS incorporates an Intel [REDACTED] modem that executes [REDACTED] baseband firmware and software, and a [REDACTED] RF transceiver. (CX-1236C.0013 (Resp. to

Interrog. No. 3)). Dr. Mangione-Smith testified that he identified a function called

[REDACTED]

⁶⁴ DCI is an acronym for “Downlink Control Information.” (See, e.g., CBr. at 91; Tr. (Acampora) at 6-23; RDX-0010.0024.).

⁶⁵ When he testified during his deposition held on January 18, 2019, Mr. Zei Whang was a Software Engineer at Apple. (RPSt. at (would be) 4 (document is not paginated)). Respondents identified Mr. Zei as a fact witness due to his knowledge about the functionality of Apple’s accused products. (*Id.*).

Public Version

[REDACTED]

[REDACTED]. (Tr. (Mangione-Smith) at 900:15-1000:18; CPX-0019C.). Dr. Mangione-Smith also testified that [REDACTED]

[REDACTED]

[REDACTED]. (Tr. (Mangione-Smith) at 1000:21-1002:4; CPX-0005C; CPX-0017C.).

Apple's corporate representative, Mr. Zhu Ji,⁶⁷ corroborated Dr. Mangione-Smiths by [REDACTED]

[REDACTED]. (CX-1559C (Ji Dep. Tr. (Jan. 17, 2019)) at 108:12-20.).

For these reasons, the iPhone XS includes the claimed "channel estimating section."
HTC:

The HTC U11 incorporates a [REDACTED] with an [REDACTED] modem that executes software and firmware code, and a [REDACTED] transceiver. (CX-1255C.0016-17, 0050-51.). The [REDACTED] executes [REDACTED] firmware and software. (Tr. (Mangione-Smith) at 945:1-948:6; CPX-0076C.). Dr. Mangione-Smith identified [REDACTED]

[REDACTED]. (Tr. (Mangione-Smith) at 936:2-937:4, 946:24-947:12; CPX-0071C; CPX-0076C; *see also* CPX-0073C (HTC U11).).

Based upon Dr. Mangione-Smith's undisputed identification of the referenced files,

⁶⁶ SNR is an acronym for "signal-to-noise ratio." (*See, e.g.*, Tr. (Goldberg) at 1982:15-18.).

⁶⁷ When he testified during his deposition taken January 17, 2019, Mr. Zhu Ji was a Senior Engineering Manager at Apple. (RPSt. at (would be) 3 (document not paginated).). Respondents identified Mr. Ji as a fact witness due to his knowledge of the functionality of the Apple Accused Products. (*Id.*).

Public Version

above, and the functions on the [REDACTED], in addition to the relevant conformance testing, Dr. Vojcic agreed, and concluded that the HTC U11, like the other accused devices using [REDACTED] chips, uses [REDACTED] [REDACTED] (Tr. (Vojcic) at 809:19-810:19.).

Therefore, based upon a preponderance of evidence, it is a finding of this decision that the HTC U11, like all other HTC Accused Products, includes the claimed “channel estimation section” for the same reasons as the iPhone 8 and for the reasons stated here.

ZTE:

The ZTE Max XL incorporates a [REDACTED] chipset with an [REDACTED] LTE modem. CX-1227 at 92-95. It is undisputed that the [REDACTED] modem executes [REDACTED] firmware and software. (Tr. (Vojcic) at 810:20-811:5 ([REDACTED] [REDACTED] [REDACTED]); CPX-0022C; *see also* CPX-0108C (ZTE Max XL).). Dr. Mangione-Smith testified that he identified the exact same files and functions for the [REDACTED] modem in the Max XL that he identified for the iPhone 8. (Tr. (Mangione-Smith) at 937:5-23, 947:13-21; CPX-0106C; CPX-0117C.). Based upon Dr. Mangione-Smith’s identification of the same files and functions on the [REDACTED] modem, Dr. Vojcic agreed with Dr. Mangione-Smith and concluded that the ZTE Max XL, like the other accused devices using [REDACTED] (Tr. (Vojcic) at 810:18-811:5, 785:14-22.).

Therefore, based upon a preponderance of (undisputed) evidence it is a finding of this decision that the ZTE Max XL, like all other ZTE Accused Products, includes a “channel estimation section” for the same reasons stated above with respect to the iPhone 8 and for the additional reasons explained in this Section.

Public Version

iii. [1b]: “a parameter deciding section that decides modulation parameters and coding parameters per subband group comprised of a plurality of the subbands, based on a result of the channel estimation per subband”

INVT alleged that the 439 Accused Products include the claimed “parameter deciding section.” (CBr. at 115-16.). The term “parameter deciding section” was construed to mean “hardware and/or software that decides modulation parameters and coding parameters per subband group comprised of a plurality of the subbands.” (*Markman* Order at 30.). The Parties agreed that the term “per subband group” means “for each subband group.” (JCC at 5; *Markman* Order at 37-38.).

In their Post-Hearing Reply Brief, Respondents did not contest that the 439 Accused Products include the claimed “parameter deciding section.” (RRBr. at 41-57.). Thus, Respondents have waived any argument on this issue under Ground Rule 10.1.

The source code that is executed by the Intel [REDACTED] and used in the iPhone XS, the [REDACTED] modem used in the iPhone 8, and the accused HTC and ZTE products [REDACTED] [REDACTED].⁶⁹ (Tr. (Mangione-Smith) at 950:20-952:22 [REDACTED] [REDACTED] [REDACTED] [REDACTED], 952:23-953:5, 955:25-956:13 (HTC U11), 953:17-24; 956:14-957:1 (ZTE Max XL), 954:13-955:24 [REDACTED])

⁶⁸ PUSCH is an acronym for “physical uplink shared channel.” (*See, e.g.*, CX-0068.0008; RX-1520.0008.).

⁶⁹ For PUSCH Mode 3-0, “[t]he UE shall report one subband CQI value for each set S subband.” (CX-0068.0034 (3GPP TS 36.213 V8.4.0)). Similarly, for PUSCH Mode 3-1, the UE “shall report one subband CQI value per codeword for each set S subband.” (*Id.*).

Public Version

[REDACTED]); CPX-0004C; CPX-0019C; CPX-0025C; CPX-0053C; CPX-0056C (Apple iPhone 8 and XS); CPX-0075C; CPX-0078C (HTC U11); CPX-0114C; CPX-0119C (ZTE Max XL). This is undisputed.

Moreover, Respondents' technical documentation and conformance testing also confirms that the 439 Accused Products practice this limitation. (Tr. (Vojcic) at 819:4-13.). For example, Apple technical documentation establishes that [REDACTED]

[REDACTED]
[REDACTED] (CX-0252C.0004; Tr. (Vojcic) at 819:19-820:10.).

The same Apple document references [REDACTED]
[REDACTED] (CX-0252C.0004.).

Additionally, [REDACTED]
[REDACTED].

Figure 29: [REDACTED]

[REDACTED]



(CX-0252C.0005.).



(CX-0068.0043; *see also* Tr. (Vojcic) at 820:11-22.).

Both tables shown above in Figure 29 contain the corresponding CQI index and modulating and coding parameters. (Tr. (Vojcic) at 820:11-25.). As Dr. Vojcic explained, “all products that comply with the standard have to use this table, because this table uniquely specifies modulation and coding that uniquely respond to an index. So if you use anything other than that, the system wouldn’t work.” (Tr. (Vojcic) at 821:1-9.).

Based upon a preponderance of evidence, which is undisputed, INVT has proven that the 439 Accused Products meet limitation [1b] of claim 1 of the ’439 patent.

- iv. [1c]: “a parameter information transmission section that transmits, to a communicating party, parameter information indicating the modulation parameters and the coding parameters decided at the parameter deciding section”*

INVT alleged that the 439 Accused Products include the claimed “parameter information transmission section,” which Respondents did not contest in their Post-Hearing Reply Brief. (CBr. at 116-17; RRBr. at 41-57.). Thus, Respondents have waived any argument on this issue

under Ground Rule 10.1.

As discussed above with respect to limitation [1b], the source code that is executed by the Intel [REDACTED] that is used in the iPhone XS; the [REDACTED] modem that is used in the iPhone 8; and the accused HTC and ZTE products include the PUSCH reporting process which is required by the LTE standard.⁷⁰ (Tr. (Mangione-Smith) at 950:20-952:22, 952:23-953:5, 955:25-956:13 (HTC U11), 953:17-24 and 956:14-957:1 (ZTE Max XL), 954:13-955:24 [REDACTED] [REDACTED]; CPX-0025; CPX-0053; CPX-0056 (Apple iPhone 8 and XS); CPX-0075; CPX-0078 (HTC U11); CPX-0114; CPX-0119 (ZTE Max XL).).

In PUSCH Mode 3-1, the LTE standard requires the UE to report CQI, decided at the UE, to the BS in the uplink. (CX-0068.0033 (3GPP TS 36.213 V.8.4.0)). Referring to Section 7.2.1 of the LTE standard, Dr. Vojcic provided the following testimony:

Q. . . . I'm showing you here CX 68, once again, and we'll move to slide 55 and do a call out of section 7.2.1. First of all, who decides the CQI value in this part of the standard?

A. In this part of the standard, it indicates that the UE decides CQI modulation encoding scheme. The first highlight really says the parameter information transmission section that transmits, et cetera, et cetera, is actually the section the UE that would transmit aperiodic CQI, which are modes 30 and 31, using the PUSCH channel, which is physical uplink share channel. So that -- that section of the UE would correspond to parameter information transmission section.

Q. Okay. Thank you. And is it possible to comply with the standard without having a parameter information transmission section, as claimed?

A. No, it wouldn't be possible, because then the base station wouldn't be informed about CQI or modulation coding scheme that it should use and, according to the channel conditions as seen by the UE, as we saw in the previous slides.

⁷⁰ "A UE shall perform aperiodic CQI, PMI, and RI reporting using the PUSCH . . ." (CX-0068.0033 (3GPP TS 36.213 V.8.4.0)).

Public Version

(Tr. (Vojcic) at 821:19-822:22 (discussing CX-0068.0033); *see also* CDX-0005C.0055.).

Based upon a preponderance of undisputed evidence, INVT has proven that the 439 Accused Products meet limitation [1c] of claim 1 of the '439 patent.

- v. ***[1d] and [1e]: [1d] “a receiving section that receives a signal containing data modulated and encoded on a per subband group basis at the communicating party using the modulation parameters and the coding parameters of the parameter information transmitted at the parameter information transmission section;” [1e] “a data obtaining section that demodulates and decodes the received signal received at the receiving section on a per subband group basis . . .”⁷¹***

Respondents contended that the 439 Accused Products do not meet the claimed “receiving section” and “data obtaining section” because, as Respondents argued, in LTE, data is not modulated and encoded, or demodulated and decoded, on a per subband group basis, as required by limitations [1d] and [1e]. (RRBr. at 41-42.). Respondents’ expert, Dr. Acampora, testified that one single set of modulation and coding parameters is used for all data, regardless of “subband group.” (Tr. (Acampora) at 1864:4-14, 1864:24-1866:15.).

INVT’s expert, Dr. Vojcic, confirmed that in LTE, the bandwidth available for communication is broken up into what are called “resource blocks.” (Tr. (Vojcic) at 862:14-863:4.). An example of contiguous resource blocks is depicted in the Figure 30 below.

⁷¹ The underlined portions of limitations [1d] and [1e] are addressed in the section below.

Figure 30: LTE System Bandwidth

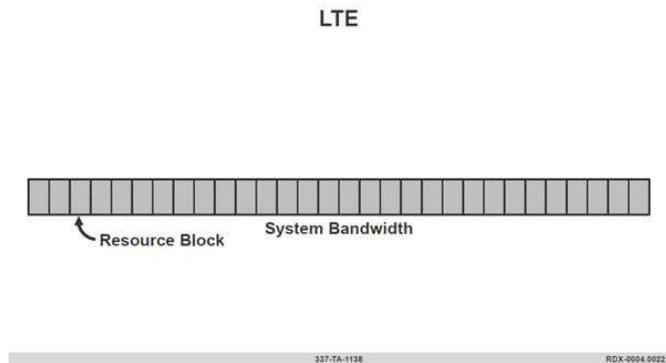

(RDX-0004.0022.).

Dr. Vojcic explained that each of the LTE subbands “is made up of a set of contiguous resource blocks.” (Tr. (Vojcic) at 863:16-18; *see also* Tr. (Acampora) at 1859:6-14.). A depiction of LTE subbands and their correspondence to the resourced blocks is provided below in Figure 31.

Figure 31: LTE Subbands

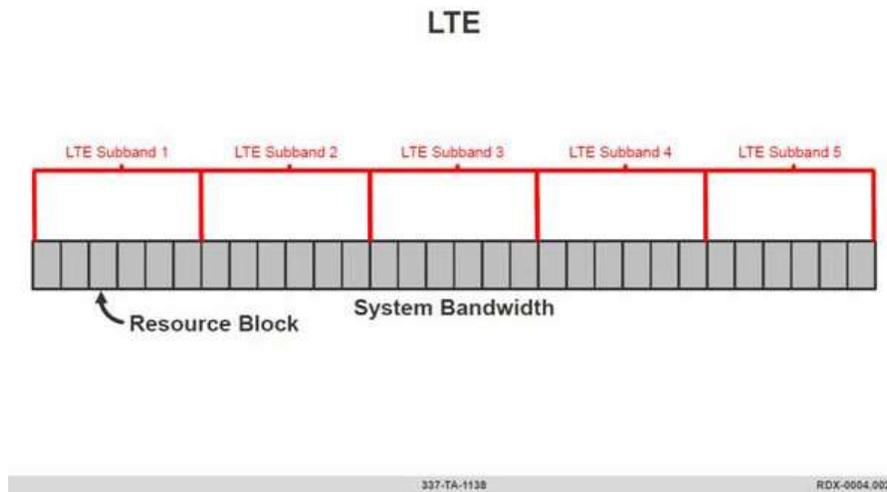

(RDX-0004.0023.).

Dr. Vojcic and Dr. Acampora both testified that in certain LTE modes, a mobile can report a channel quality indicator, or “CQI,” per LTE subband. (Tr. (Vojcic) at 865:7-866:3; Tr.

Public Version

(Acampora) at 1858:3-14; RX-1520.0034-35.). However, both experts, Dr. Vojcic and Dr. Acampora agreed that the LTE subbands do not play a role in the modulation and coding of data. Both experts also agreed that when a mobile unit (or, e.g. phone) is to receive a transmission, the base station will send the mobile a “downlink control indicator” or “DCI” message, which includes a resource block assignment telling the mobile what portions of the bandwidth to use to receive data. (Tr. (Vojcic) at 867:22-868:4, 868:23-869:8; Tr. (Acampora) at 1860:2-1861:6.). Dr. Vojcic testified that “the base station could assign as little as one resource block” or it “could theoretically assign the entire bandwidth of all the resource blocks to the mobile.” (Tr. (Vojcic) at 869:19-870:2.). He also testified that the resource blocks assigned to a specific mobile unit can span multiple LTE subbands. (*Id.* at 870:3-17.).

In that same DCI message, the base station provides an “MCS,” or modulation and coding scheme” value that the mobile unit uses along with the resource block assignment to determine the parameters that it must use to demodulate and decode the received data. (Tr. (Vojcic) at 871:5-10; Tr. (Acampora) at 1860:6-23.). However, as Dr. Vojcic and Dr. Acampora both testified, no matter how many LTE subbands are spanned by the resource block assignment, only one set of modulation and coding parameters will ever be used to modulate and encode the data at the base station. (Tr. (Vojcic) at 871:18-872:9, 873:15-874:21; Tr. (Acampora) at 1861:13-23, 1864:24-1865:17, 1867:4-15.). As Dr. Acampora put it, “[t]here’s only one modulation and coding scheme used on the downlink per UE.” (Tr. (Acampora) at 1861:22-23.). Dr. Vojcic agreed, testifying that “the base station will assign one and only one modulation and coding scheme” and that it will do so “regardless of how many LTE subbands the resource blocks may span.” (Tr. (Vojcic) at 873:24-874:11.).

Similarly, regardless of how many LTE subbands are spanned by the resource block

Public Version

assignment, only one MCS index value will be provided in the DCI message that identifies only a single set of parameters that the mobile unit will use to demodulate and decode the data. Dr. Acampora testified that the 439 Accused Products “will *not* demodulate and decode per subband group,” but rather “will demodulate and decode all the resource blocks using the same modulation and coding scheme no matter where those resource blocks happen to fall.” (Tr. (Acampora) at 1868:2-19 (emphasis added).). Dr. Vojcic agreed with Dr. Acampora that “the mobile will only decode and demodulate those resource blocks with the single modulation scheme and coding scheme specified by the base station in the DCI message” and it will do so “regardless of how many LTE subbands the resource block assignment may span.” (Tr. (Vojcic) at 874:12-21.).

As Dr. Acampora pointed out, the functionality described above in the preceding paragraph is required explicitly by the LTE standard. (Tr. (Acampora at 1864:4-14.). Section 5.1.7.1 of TS 36.300 states that “Link adaptation (AMC: adaptive modulation and coding) with various modulation schemes and channel coding rates is applied to the shared data channel” and that “[t]he same coding and modulation is applied to all groups of resource blocks[.]” (RX-1523.0018.). The LTE standard does not provide “any ability to use multiple modulation and coding schemes corresponding to multiple LTE subbands.” (Tr. (Acampora) at 1866:12-15.).

INVT asserted that Respondents’ “per subband group” argument fails because claim 1 “never states that modulation or demodulation must occur *differently* for every subband group,” and that claim 1 requires only that data be “modulated and encoded” and “demodulate[d] and decode[d]” “for each subband group.” (CBr. at 100-01 (emphasis in original).). However, as Respondents correctly pointed out, the “receiving section” and “data obtain section” limitations of claim 1 both build upon the “parameter deciding section” limitation, which recites “a

Public Version

parameter deciding section that decides modulation parameters and coding parameters *per subband group*.” (JX-0003 at cl. 1 (emphasis added)). Under the adopted construction of this limitation, parameters must be decided “for each subband group.” (*Markman* Order at 38.).

Claim 1 refers back to the parameters decided for each subband group in the subsequent limitations. The receiving section limitation of the asserted claims requires that data received at the claimed device is “modulated and encoded on a *per subband group basis*” using the parameters decided for each subband at the parameter deciding section. (Tr. (Vojcic) at 859:19-23.). Likewise, the data obtaining section requires that data received at the claimed device is “demodulated and decoded on a *per subband group basis*” using those same parameters. (*Id.* at 860:24-861:2.). This is consistent with the specification of the ’439 patent, which describes per subband group modulation and coding parameters.

[O]utput 603 of adaptive modulating/coding section 301 contains transmission data on the order of subband groups 1, 2, . . . K, where the modulation methods and coding methods are (C1, M1), (C2, M2), . . . , (CK, MK), where K is the total number of subband groups divided within OFDM.

(JX-0003 at 8:44-49.).

As Respondents noted, INVT’s interpretation would rewrite claim 1 so that the claim simply requires that data be “modulated and encoded” for each subband group, and also “demodulate[d] and decode[d]” “for each subband group. (CBr. at 100-01.). That is, INVT argued that “the same modulation and coding scheme can properly be applied . . . to all subbands over the full channel bandwidth,” so long as all of the subband groups are modulated/demodulated and encoded/decoded.⁷² (*Id.* at 101-02.). That is not what claim 1

⁷² For its argument, Complainant relied on material that explicitly was excluded. (*See* CBr. at 102 (citing CDX-0014C.0063-64, Complainant’s Offer of Proof (EDIS Doc. No. 689067)); Tr. 2390:13-15 (denying

recites or requires.

Based upon the evidence and discussion in this section, INVT has failed to prove by a preponderance of the evidence that the 439 Accused Products meet limitations [1d] and [1e] of claim 1 of the '439 patent.

- vi. *1[e]: “a data obtaining section that demodulates and decodes the received signal received at the receiving section on a per subband group basis using the modulation parameters and the coding parameters decided at the parameter deciding section, and obtains the data contained in the received signal”*⁷³

INVT alleged that the 439 Accused Products include the claimed “data obtaining section.” (CBr. at 117-18.). The term “data obtaining section” was construed to mean “hardware and/or software that demodulates and decodes the received signal received at the receiving section on a per subband group basis using the modulation parameters and the coding parameters decided at the parameter deciding section.” (*Markman* Order at 34-35; *see also* Order No. 52 at 3.).⁷⁴

INVT’s expert, Dr. Mangione-Smith, testified that the source code executed by the relevant Intel and [REDACTED] modems in Respondents’ products [REDACTED] [REDACTED]. (Tr. (Mangione-Smith) at 993:9-996:11; CPX-0050C (Apple iPhone 8); CPX-0073C; CPX-0084C (HTC U11); CPX-0108C-110C (ZTE Max XL).). Dr. Vojcic also

Complainant’s request to present rebuttal testimony from Dr. Vojcic regarding infringement), 2404:6-2405:2 (denying Complainant’s motion for reconsideration regarding the scope of Dr. Vojcic’s rebuttal).).

⁷³ The underlined portion of limitation [1e] is addressed in the section below.

⁷⁴ *See also* Section VIII.A, *supra*, with respect to the discussion on patent essentiality of claim 1 of the '439 patent.

Public Version

testified that Respondents' accused devices passed the relevant certification tests for Modes 3-0 and 3-1 aperiodic CQI reporting, and therefore must implement the relevant portions of the LTE standard that practice the limitations of the '439 patent, including reporting CQI and transmitting the best CQI according to the UE CQI report. (Tr. (Vojcic) at 802:15-803:25, 805:8-806:7, 808:10-25, 837:12-838:1; CX-0218C.0517; CX-0275C.0133; CX-0332C; *see also* INVT's Offer of Proof (EDIS Doc. No. 689067) at 11-12 (discussing Section 9.3.1.1.1.4.2 of the Certification Test)).

Dr. Benjamin Goldberg,⁷⁵ Respondents' expert witness with respect to source code, acknowledged that in both the 439 Accused Products that use [REDACTED] chips (Apple iPhone 8, HTC U11, ZTE Max XL), and the 439 Accused Products that use Intel-based chips (Apple iPhone XS), the [REDACTED] [REDACTED]. (See Tr. (Goldberg) at 1965:19-1966:7, 1968:16-1969:13, 1970:6-17, 1971:2-11, 1972:8-13; RPX-0107C; RPX-0108C.).

However, Dr. Goldberg persuasively explained that without the benefit of reviewing source code governing the operation of the base station communicating with an accused device, it is not possible to determine whether the information in the DCI message is "informed in any way by a CQI value that was sent earlier [from the accused UE]." As Dr. Goldberg testified, even if the CQI reported by the UE to the base station could be considered to include the initial determination of modulation and coding parameters, it is not possible to know whether the base

⁷⁵ When he testified during the Hearing on September 10, 2019, Dr. Benjamin Goldberg was an Associate Professor in the Department of Computer Science at New York University. (RPSt. at Ex. 4.). Respondents identified Dr. Goldberg as an expert to testify about the operation of source code for the Accused Products and the Domestic Industry Products as it relates to all asserted patents. (RPSt. at (would be) 2 (document not paginated)).

Public Version

station decides to use these “very parameters” (as specified by Order No. 52) without reviewing base station source code.

Q. Now can you determine from the source code alone whether the parameters that the source code extracts from a DCI message are informed in any way by a CQI value that was sent earlier?

A. No, you can’t tell from looking at the handset code.

Q. What source code would you need to look at in order to understand whether that happens?

A. You would need to look at the base station code.

* * *

And so the handset -- the code in the handset needs lots of information to configure demodulation that is unrelated to the CQI that was sent up. And *there’s no way to know if the base station was influenced by that CQI or not, because we don’t have that code.*

(Tr. (Goldberg) at 1973:25-1974:11, 1975:24-1976:4 (emphasis added).).

Given the lack of source code for the handset that INVT failed to discuss, there is a significant evidentiary gap about whether and how the base station is influenced by a CQI code, as Dr. Goldberg testified. As a result, INVT has failed to prove by a preponderance of the evidence that the 439 Accused Products practice the additional element of limitation [1e] of claim 1 of the ’439 patent.

- vii. *[1f]: “a pattern storage section that stores in advance patterns for selecting subbands constituting the subband groups wherein the parameter deciding section decides the modulation parameters and the coding parameters per subband group comprised of the subbands selected based on the patterns stored in the pattern storage section”*

In its Initial Post-Hearing Brief, INVT did not raise any arguments or present any evidence to demonstrate that the 439 Accused Products satisfy this claim limitation for purposes of infringement. (CBr. at 111-118.). INVT addressed limitation [1f] only in the context of

Public Version

alleging that the asserted claims are standard-essential. (CBr. at 94-109.). Because it is finding of this ID that the asserted claims are not standard-essential, INVT cannot meet its burden of proof that the 439 Accused Products practice limitation [1f] by merely establishing that the LTE standard meets this limitation. *Optis Wireless*, 2018 WL 3375192, at *1.

Accordingly, INVT has failed to prove by a preponderance of the evidence that the 439 Accused Products meet limitation [1f] of claim 1 of the '439 patent.

b) Dependent Claim 2

- i. “The communication apparatus of claim 1, wherein the parameter deciding section decides the modulation parameters and the coding parameters per subband group constituted from a pattern, among the patterns, for selecting a plurality of the subbands neighboring on a frequency axis.”*

For the reasons stated above in the discussion of claim 1, claim 1 is not infringed. Since claim 2 depends from claim 1, claim 2 is not infringed. *See Muniauction, Inc. v. Thomson Corp.*, 532 F.3d 1318, 1328-29 n.5 (Fed. Cir. 2008) (“A conclusion of noninfringement as to the independent claims requires a conclusion of noninfringement as to the dependent claims.”); *Monsanto Co. v. Syngenta Seeds, Inc.*, 503 F.3d 1352, 1359 (Fed. Cir. 2007) (“One who does not infringe an independent claim cannot infringe a claim dependent on (and thus containing all the limitations of) that claim.”); *Wahpeton Canvas Co., Inc. v. Frontier, Inc.*, 870 F.2d 1546, 1553 (Fed. Cir. 1989) (“It is axiomatic that dependent claims cannot be found infringed unless the claims from which they depend have been found to have been infringed.”).

C. Technical Prong of Domestic Industry

1. Technical DI Overview

INVT alleged that it meets the technical requirement of domestic industry because claim 1 allegedly reads onto the same technical standards that INVT cites for infringement of the

accused products and that the representative Samsung Galaxy S9 product ⁷⁶ complies with the asserted standards.⁷⁷ For the same reasons the 439 Accused Products do not infringe the 439 DI Products, INVT has failed to demonstrate that claim 1 reads onto the LTE technical standard. Thus, INVT has not satisfied the technical requirement of domestic industry via compliance with the standard. Specifically, INVT has failed to demonstrate that the 439 DI Products include the claimed “receiving section” and “data obtaining section,” as recited in limitations [1d] and [1e] of claim 1 of the ’439 patent.

2. INVT Failed to Prove That the 439 DI Products Practice Independent Claim 1 and Dependent Claim 2 of the ’439 Patent

a) Independent Claim 1

ii. [1Pre]: “A communication apparatus comprising”

Respondents did not dispute that each of the 439 DI Products is a communication terminal apparatus because each is capable of communicating over 3G and LTE networks. (CX-0178C at 1138ITC-SEA000000472 at 0542; RRBr. at 41-58.). Thus, Respondents have waived any argument on this issue under Ground Rule 10.1.

Accordingly, INVT has proven by a preponderance of the evidence that the 439 DI Products meet the preamble of claim 1 of the ’439 patent.

iii. [1a]: “a channel estimating section that carries out a channel estimation per subband”

It is undisputed that the Samsung Galaxy S9 incorporates a [REDACTED] with an [REDACTED] modem that executes [REDACTED] software and firmware. (CX-0178C-0014;

⁷⁶ See Representative Product Stipulation. (Doc. ID No. 688512 (Sept. 18, 2019) (Samsung Galaxy S9 representative of DI Products).).

⁷⁷ Samsung is licensed to the Asserted Patents. (JX-0016C.0006; CX-0460C.0006.). Complainant relied on Samsung’s licensed products to satisfy the technical prong of domestic industry. (CBr. at 2, 118-21.).

Public Version

Tr. (Vojcic) at 785:19-786:1.). Dr. Mangione-Smith testified that he identified the exact same files and functions for the [REDACTED] modem in the Galaxy S9 that he identified in the iPhone 8, which also incorporates a [REDACTED] and LTE modem. (Tr. (Mangione-Smith) at 937:24-938:15 [REDACTED]
[REDACTED], 945:1-948:6 [REDACTED]
[REDACTED], 953:17-957:15 [REDACTED]; CPX-0031C; CPX-0033C; CPX-0037C; CPX-0038C.).

Based upon Dr. Mangione-Smith's identification of the same files and functions on the X20 modem, Dr. Vojcic concluded that the Galaxy S9 includes the claimed "channel estimating section" for the same reasons as the iPhone 8. (Tr. (Vojcic) at 785:19-786:1, 810:25-811:22.).

For these reasons, INVT has proven by a preponderance of the evidence that the 439 Accused Products practice limitation [1a] of claim 1 of the '439 patent.

iv. [1b]: "a parameter deciding section that decides modulation parameters and coding parameters per subband group comprised of a plurality of the subbands, based on a result of the channel estimation per subband"

Respondents did not dispute in their Post-Hearing Brief that the Samsung Galaxy S9 includes the claimed "parameter deciding section." (RRBr. at 41-58.). Thus, Respondents have waived any argument on this issue under Ground Rule 10.1.

Dr. Mangione-Smith testified that he identified the exact same files and functions for the [REDACTED] modem in the Galaxy S9 that he identified in the iPhone 8. (Tr. (Mangione-Smith) at 993:9-996:11 [REDACTED]
[REDACTED]
[REDACTED], 995:19-21 ("Q. And did you also look for this file in the code operating on the Galaxy

Public Version

S9? A. Yes, sir.”); CPX-0035 (Galaxy S9); CPX-0045; *see also* Tr. (Mangione-Smith) at 950:20-952:22 [REDACTED]
[REDACTED]
[REDACTED], 954:13-955:24
[REDACTED]).

Based upon Dr. Mangione-Smith’s identification of the same files and functions on the X20 modem, Dr. Vojcic also concluded that the Galaxy S9 includes the claimed “parameter deciding section” for the same reasons as the iPhone 8. (Tr. (Vojcic) at 785:19-786:1, 819:4-13.).

Therefore, INVT has proven by a preponderance of the evidence that the 439 Accused Products practice limitation [1b] of claim 1 of the ’439 patent.

- v. ***[1c]: “a parameter information transmission section that transmits, to a communicating party, parameter information indicating the modulation parameters and the coding parameters decided at the parameter deciding section”***

Respondents did not contest in their Post-Hearing Reply Brief that the Galaxy S9 includes the claimed “parameter information transmission section.” which Respondents did not contest in their Post-Hearing Reply Brief. (RRBr. at 41-58.). Thus, Respondents have waived any argument on this issue under Ground Rule 10.1.

Dr. Mangione-Smith testified that he identified the exact same files and functions for the [REDACTED] modem in the Galaxy S9 that he identified in the iPhone 8. (Tr. (Mangione-Smith) at 993:9-996:11 [REDACTED] and “what’s happening is the [REDACTED]
[REDACTED]; CPX-0033C; CPX-0036C; CPX-0037C; CPX-0038C; CPX-0045C; *see also* Tr.

(Vojcic) at 822:1-12 [REDACTED]

[REDACTED]; Tr. (Mangione-Smith) at 950:20-952:22 (“So at those lines, [REDACTED]

[REDACTED]), 954:13-955:24 [REDACTED]

[REDACTED].).

Based upon Dr. Mangione-Smith’s identification of the same files and functions on the [REDACTED] modem, Dr. Vojcic also concluded that the Galaxy S9 includes the claimed “parameter information transmission section” for the same reasons as the iPhone 8. (Tr. (Vojcic) at 822:23-823:10.).

Accordingly, INVT has proven by a preponderance of the evidence that the 439 Accused Products practice limitation [1c] of claim 1 of the ’439 patent.

- vi. ***[1d] and [1e]: [1d] “a receiving section that receives a signal containing data modulated and encoded on a per subband group basis at the communicating party using the modulation parameters and the coding parameters of the parameter information transmitted at the parameter information transmission section;” [1e] “a data obtaining section that demodulates and decodes the received signal received at the receiving section on a per subband group basis using the modulation parameters and the coding parameters decided at the parameter deciding section, and obtains the data contained in the received signal”***

INVT alleged that it meets the technical requirement of domestic industry because claim 1 allegedly reads onto the same technical standards that INVT relied on for infringement of the 439 Accused Products, and that the Samsung Galaxy S9 product complies with the asserted standards. (CBr. at 118.). For the same reasons discussed for infringement, the evidence does not demonstrate that claim 1 reads onto the technical standards. (See Section VIII.A, *supra*.).

Thus, INVT has not satisfied the technical requirement of domestic industry via compliance with the standard.

Additionally, the evidence indicates that the Samsung Galaxy S9 product uses a [REDACTED] chip, which employs functionality that is essentially the same as the functionality of the [REDACTED] chip embedded in the [REDACTED] accused products. (Tr. (Goldberg) at 1965:19-1966:7; RPX-0108C; 1968:16-1969:13; 1970:6-17; 1971:2-11; 1972:8-13; 1973:25-1974:11; 1975:24-1976:4; RPX-0107C.). Accordingly, for the same reasons discussed in Section VIII.B that reach a finding that [REDACTED] 439 Accused Products do not infringe, INVT has not met its burden of establishing by a preponderance of evidence that the 439 DI Products practice limitations [1d] and [1e] of claim 1 of the '439 patent.

Specifically, it is a finding of this decision that INVT failed to prove by a preponderance of evidence that the 439 DI Products include: “a receiving section that receives a signal containing data modulated and encoded on a *per subband group basis*;” “a data obtaining section that demodulates and decodes the received signal received at the receiving section on a *per subband group basis*;” and “a data obtaining section that demodulates and decodes the received signal received at the receiving section . . . *using the modulation parameters and the coding parameters decided at the parameter deciding section.*”

- vii. *[1f]: a pattern storage section that stores in advance patterns for selecting subbands constituting the subband groups wherein the parameter deciding section decides the modulation parameters and the coding parameters per subband group comprised of the subbands selected based on the patterns stored in the pattern storage section*

In its Initial Post-Hearing Brief, INVT did not argue or present any evidence to prove that the 439 DI Products satisfy this claim limitation for purposes of infringement. (CBr. at 111-118.). INVT addressed limitation [1f] only in the context of alleging that the asserted claims are

standard-essential. (CBr. at 94-109.). Because it is finding of this ID that the asserted claims are not standard-essential, INVT cannot and did not meet its burden of showing that the 439 DI Products practice limitation [1f] by merely establishing that the LTE standard meets this limitation. *Optis Wireless*, 2018 WL 3375192, at *1.

Accordingly, INVT has failed to prove by a preponderance of the evidence that the 439 Accused Products meet limitation [1f] of claim 1 of the '439 patent.

D. Invalidity

1. Invalidity Overview

Respondents contended that the technology claimed in the '439 patent is obvious in view of the combination of three prior art references, Li, Vijayan, and Hashem.⁷⁸ (RBr. at 35-46.). For the following reasons, Respondents have not met their burden of proving by clear and convincing evidence that the combination of these three (3) prior art references teaches the technology claimed in the '439 patent.

As an initial matter, none of the referenced prior art references discloses limitation [1b], which requires “a parameter deciding section that decides modulation parameters and coding parameters *per subband group* comprised of a plurality of the subbands, based on a result of the *channel estimation per subband*.” (JX-0003 at cl. 1 (emphases added).).

Respondents failed to prove how the missing limitation is obvious in view of the combination of the three (3) prior art references. Additionally, for the reasons discussed immediately below, INVT presented compelling rebuttal evidence and testimony why a person of ordinary skill in the art would not be motivated to combine Li with Vijayan or Hashem.

⁷⁸ U.S. Patent Nos. 6,904,283 (Li); 7,221,680 (Vijayan); 6,721,569 (Hashem).

In their Pre-Hearing Brief, Respondents also argued that the asserted claims are invalid for lack of sufficient written description support in the specification of the '439 patent. (RPBr. at 48-49.). However, Respondents did not discuss this argument, or provide evidence to support their argument in their Initial Post-Hearing Brief. Thus, Respondents have waived any argument on this issue under Ground Rule 10.1.

2. Respondents Failed to Prove That the Combination of Li (RX-1615), Vijayan (RX-1616), and Hashem (RX-1617) Render Obvious Independent Claim 1 and Dependent Claim 2 of the '439 Patent

U.S. Patent No. 6,904,283 (“Li”) is entitled “Multi-Carrier Communications with Group-Based Subcarrier Allocation.” (RX-1615.). Li discloses an OFDM⁷⁹ system that “partition[s] subcarriers into groups of at least one cluster of subcarriers.” (*Id.*). As Li teaches in its Abstract, the system receives an indication of a selection by a subscriber of one or more groups in the groups and allocates at least one cluster in the one or more groups of clusters selected by the subcarrier for use in communication with the subscriber. (*See id.* at Abstract.). The evidence is persuasive and effectively undisputed that Li’s “adaptive modulation and coding,” is performed on “a per-subband” basis, not a “*per subband group*” basis, as required by the asserted claims.⁸⁰ (Tr. (Vojcic) at 2483:2-12, 2484:13-25; *see also* Tr. (Acampora) at 1925:25-1926:4 (“SINR is reported on a per subband basis in Li.”); RX-1615 at Figs. 5 (SINR per “cluster”), 6.).

U.S. Patent No. 7,221,680 (“Vijayan”) is entitled “Multiplexing and Transmission of Multiple Data Streams in a Wireless Multi-Carrier Communication System.” (RX-1616.).

⁷⁹ OFDM is an acronym for “orthogonal frequency division multiplexing.” (*See, e.g.*, JX-0003 at 1:13-14.).

⁸⁰ The Parties agreed that “per subband” means “for each subband,” as opposed to “per subband group,” which the Parties agreed means “for each subband group,” i.e., more than one subband. (*Markman* Order at 37-38.).

Public Version

Vijayan discloses transmission of multiple data streams that occur in “super-frames.” (*Id.* at Abstract.). According to Vijayan’s Abstract, each super-frame has a predetermined time duration and is divided into multiple frames. (*See, e.g., id.*). Each data block for each data stream is outer encoded to generate a corresponding code block. (*See, e.g., id.*). Each code block is partitioned into multiple subblocks, and each data packet in each code block is inner encoded and modulated to generate modulation symbols for a packet. (*See, e.g., id.*). As both INVT’s and Respondents’ experts agreed, none of the teachings in Vijayan involve modulation and coding parameters based on *channel estimation from the UE* or *channel estimation per subband*. (Tr. (Vojcic) at 2483:17-22; Tr. (Acampora) at 1929:18-25, 1930:7-12, 1932:7-23 (“I’m not opining that the modulation and coding parameters used in the downlink over a mode was determined at the UE Vijayan is silent as to where the modulation coding scheme used for mode is computed.”)).

U.S. Patent No. 6,721,569 (“Hashem”) is entitled “Dynamic Sub-Carrier Assignment in OFDM Systems.” (RX-1617.). Hashem teaches a method and apparatus for selecting and signaling the identity of sub-carriers to be used for transmission of data in a radio communication system, and for using other sub-carriers. (*See id.* at Abstract.). As Hashem’s Abstract discloses, a remote unit determines which sub-carriers are acceptable for use in data transmission by comparing the signal to interference ratio of each subcarrier with a threshold. (*See id.*). A base station transmits data over the acceptable sub-carriers at the optimum Link Mode(s). (*See id.*). Hashem teaches flagging subcarriers or sets of adjacent subcarriers (i.e., subbands) as acceptable or unacceptable. (*See, e.g., id.* at 2:25-27, 8:21-44.). Thus, Hashem does not disclose AMC *per subband group*. (Tr. (Acampora) at 1934:13-21 (“Hashem uses subband to mean subcarrier”), 1935:1-10 (“[i]n Hashem every subcarrier get measured”); *see*

Public Version

also Tr. (Vojcic) at 2483:23-2284:7, 2489:23-2490:9.).

Respondents' expert witness, Dr. Acampora, confirmed that none of the references alone teaches the "parameter deciding section" recited in limitation [1b].

Q. . . . Element 1.b of the '439 Patent is a parameter deciding section that decides modulation parameters and coding parameters per subband group comprised of a plurality of the subbands based on a result of the channel estimation per subband. . . . There it is, element 1.b. I just read it. That claim element, as it stands, is not present in any single reference that you've brought in here today, is it, Dr. Acampora?

A. Not quite. I agree. . . . I do agree that both of those halves of the -- or parts of the 1B are not in any one reference. It's the combination that would teach that.

(Tr. (Acampora) at 1939:17-1940:17.).

Dr. Acampora opined that the combination of references teaches limitation [1b]. (*Id.*) However, INVT's expert, Dr. Vojcic, persuasively testified that a person of ordinary skill in the art would not combine Li with Vijayan or Hashem.

For instance, Dr. Vojcic explained that one of ordinary skill would not combine Li with Vijayan because Li's fundamental invention expressly teaches away from Vijayan's purported joint modulation and coding scheme. (RX-1615 at 7:9-35, 7:66-8:5; Tr. (Vojcic) at 2488:15-21.). Li's goal with frequency diverse groups of clusters is to provide diversity through different modulation and coding rates for different clusters to "support reliable transmission over channels with different SINR."⁸¹ (RX-1615 at 1:64-67, 11:62-67; Tr. (Vojcic) at 2497:2-2498:4.). By contrast, Vijayan is concerned with efficient resource allocation by using the same modulation and coding schemes on neighboring subbands. (Tr. (Vojcic) at 2488:22-2489:17.). Dr. Vojcic testified that one skilled in the art reading Li would not incorporate joint modulation and coding

⁸¹ SINR is an acronym for "signal-to-interference/noise ratio." (*See, e.g.*, RX-1615 at 5:44-45; RX-1616 at 3:20.).

Public Version

parameters because such incorporation would destroy Li's ability to improve performance by adaptively applying *different* parameters to subbands experiencing *different* channel conditions to achieve the diversity gain. (*Id.*; *see also id.* at 2489:5-17, 2493:1-22 (criticizing assigning the "same modulation and coding parameters as per Vijayan" to clusters with "different channel conditions").).

Specifically, Dr. Vojcic explained that Li and Vijayan teach conflicting ways to achieve diversity that are not interchangeable. Li's objective is to "maximize frequency diversity" by spreading out subbands in a given subband group in the frequency domain. (Tr. (Vojcic) at 2512:1-10, 2517:12-23; Tr. (Acampora) at 1926:9-16 ("I'll accept what you characterized as being spread out over the bandwidth.")). To the contrary, Vijayan's goal of "maximizing time diversity" involves compressing subbands within a group until they become neighbors in the frequency domain. (Tr. (Vojcic) at 2517:24-2518:6; *see also id.* at 2488:22-2489:4, 2489:5-17; RX-1616 at Figs. 7A, 9B.). Dr. Acampora agreed that "Vijayan is grouping together subband groups . . . contiguously along the frequency axis." (Tr. (Acampora) at 1932:24-1933:7; *see also id.* at 1933:13-1934:7 ("I would need to see the text accompanying this, but I do agree that it appears from this drawing without reading anything further about it that Vijayan's subband groups 3, 4, 5 and 6 [of Figure 7A] are contiguous in the frequency domain.")).

Referencing Dr. Vojcic's testimony on cross-examination, Respondents argued that Li discloses "clusters that are both coherent and diverse," and that Li and Vijayan are interchangeable. (RBr. at 45; Tr. (Vojcic) at 2512:22-2513:1.). On redirect, Dr. Vojcic clarified his previous testimony.

Q. I did want to give you the opportunity to finish your explanation about Vijayan and Li.

Public Version

A. Yes. There were -- Mr. Appleby sort of implied that I just inferred one thing about Vijayan versus Li. I forgot the exact question. And I had actually inferred multiple things there, that -- so I said, first, it's -- I think I answered [Vijayan] has coherent grouping, *unlike Li*, that's frequency diverse spacing is far apart, so it's *direct incompatibility*.

(Tr. (Vojcic) at 2517:15-23 (emphases added).).

As INVT pointed out, Li discloses coherent *clusters* (i.e., subbands), not coherent *cluster groups*. (RX-1615 at 14:26-39 (defining "coherence clusters" as "containing multiple *subcarriers* close to each other") (emphases added).).

Dr. Vojcic also testified that a person of ordinary skill would not combine Li and Hashem. He explained that Li's objective to reduce the signaling overhead is achieved by decreasing the amount of information transmitted or by minimizing the need for reallocating subbands. (RX-1615 at 12:22-23 (sending just group ID "can significantly reduce the feedback overhead"), 15:45-52 ("alleviate the overhead of frequent cluster reallocation"); Tr. (Vojcic) at 2491:23-2492:16, 2506:17-19.).

To the contrary, Hashem discloses the transmission of information for "all acceptable subcarriers" in the form of a "bitmap," "every time." (Tr. (Acampora) at 1937:19-1938:12.). Dr. Vojcic explained that "in addition to [the] CQI index that has to be reported, the UE or mobile station would have to transmit 360-bits bit mask, which is huge overhead" comparable to the "average message in [the] LTE standard." (Tr. (Vojcic) at 2492:4-16, 2483:23-2484:7 ("bit mask introduces massive overhead").).

Additionally, as Dr. Acampora explained, Hashem "changes all the time what's acceptable and unacceptable," such that subcarriers "are identified on the fly." (Tr. (Acampora) at 1935:25-1936:17; *see also* Tr. (Vojcic) at 2483:23-2484:7.). Thus, according to Dr. Acampora, Hashem's need to constantly reallocate subbands to subband groups would increase

overhead, contrary to Li.

For the foregoing reasons, Respondents have failed to prove by clear and convincing evidence that the combination of Li, Vijayan, and Hashem renders obvious claims 1 and 2 of the '439 patent.

3. INVT Failed to Prove Secondary Considerations of Non-Obviousness

For the reasons set forth immediately above, Respondents have not proven by clear and convincing evidence that claims 1 and 2 are invalid as obvious. Because the evidence is insufficient to prove that the '439 patent is invalid under 35 U.S.C. § 103, an analysis of the secondary considerations of non-obviousness is unnecessary.

Moreover, in its Post-Hearing Reply Brief, INVT failed to argue or to present any evidence with respect to secondary considerations of non-obviousness. (CRBr. at 15-20.). Thus, INVT has waived any argument on this issue under Ground Rule 10.1.⁸²

IX. DOMESTIC INDUSTRY REQUIREMENT: ECONOMIC PRONG

A. Legal Standard

The Commission may only find a violation of Section 337 “if an industry in the United States relating to the articles protected by the patent . . . exists or is in the process of being established.” 19 U.S.C. § 1337(a)(2) (emphases added). Typically, a complainant must show that a domestic industry existed at the time the complaint was filed. *See Motiva LLC v. Int'l Trade Comm'n*, 716 F.3d 596, 601 n.6 (Fed. Cir. 2013).

⁸² In its Pre-Hearing Brief, Complainant asserted two (2) separate bases for secondary considerations of nonobviousness: “(1) the commercial success of the Accused Products and (2) that Samsung has taken a license to the '439 patent, where companies do not typically take licenses to patents believed to be obvious.” (CPBr. at 73.). Complainant cited only one exhibit in support of these assertions, which has since been withdrawn. (*Id.* citing CX-1554 (B. Vojcic Rebuttal Expert Report re: Validity of '711 and '439; Doc. ID No. 695801 (Nov. 27, 2019) (Complainant’s Corrected Final Evidentiary Hearing Exhibit List)).

Public Version

A complainant satisfies the “economic prong” of the domestic industry requirement when it demonstrates that the economic activities set forth in subsections (A), (B), and/or (C) of Section 337(a)(3) have taken place or are taking place with respect to the protected articles. *See id.*

Subsection 337(a)(3) states that:

(3) For purposes of paragraph (2), and industry in the United States shall be considered to exist if there is in the United States, with respect to the articles protected by the patent, copyright, trademark, mask work, or design concerned –

- (A) significant investment in plant and equipment;
- (B) significant employment of labor, or capital; or
- (C) substantial investment in its exploitation, including engineering, research and development, or licensing.

19 U.S.C. § 1337(a)(3).

Because the criteria are listed in the disjunctive, satisfaction of any one of them will be sufficient to meet the economic prong of the domestic industry requirement. *Certain Integrated Circuits, Chipsets and Prods. Containing Same*, Inv. No. 337-TA-428, Order No. 10, Initial Determination (May 4, 2000) (“*Integrated Circuits*”) (unreviewed). Establishment of the “economic prong” is not dependent on any “minimum monetary expenditure” and there is no need for a complainant “to define the industry itself in absolute mathematical terms.” *Certain Stringed Musical Instruments and Components Thereof*, Inv. No. 337-TA-586, Comm’n Op. at 25-26 (May 16, 2008) (“*Stringed Instruments*”). However, a complainant must substantiate the nature and the significance of its activities with respect to the articles protected by the patent at issue. *Certain Printing and Imaging Devices and Components Thereof*, Inv. No. 337-TA-690, Comm’n Op. at 30 (Feb. 17, 2011) (“*Imaging Devices*”).

The Commission has interpreted Sections 337(a)(3)(A) and (B) to concern “investments

Public Version

in plant and equipment and labor and capital with respect to the *articles* protected by the patent.” *Certain Ground Fault Circuit Interrupters and Prods. Containing Same*, Inv. No. 337-TA-739, 2012 WL 2394435, at *50, Comm’n Op. at 78 (June 8, 2012) (“*Circuit Interrupters*”) (emphasis in original) (quoting 19 U.S.C. §§ 1337(a)(3)(A), (B)).

When a complainant proceeds under Section 337(a)(3)(C), it is not sufficient for the “substantial investment” under subsection (C) to merely relate to articles protected by the asserted patents. Rather, “the complainant must establish that there is a nexus between the claimed investment and the asserted patent, regardless of whether the domestic-industry showing is based on licensing, engineering, or research and development.” *Certain Integrated Circuit Chips & Prods. Containing the Same*, Inv. No. 337-TA-859, Comm’n Determination, 2014 WL 12796437, at *22 (Aug. 22, 2014) (“*Integrated Circuit Chips*”).

In addition, the Commission has definitively stated that investments in plant and equipment or labor and capital that relate to engineering and research and development (“R&D”) (that are expressly identified under subsection (C)), are properly considered under subsections (A) and (B):

The statutory text of section 337 does not limit sections 337(a)(3)(A) and (B) to investments related to manufacturing or any other type of industry. It only requires that the domestic investments in plant and equipment, and employment of labor or capital be “with respect to the articles protected by the patent.” 19 U.S.C. § 1337(a)(3). Moreover, even though subsection (C) expressly identifies “engineering” and “research and development” as exemplary investments in the “exploitation” of the patent, that language does not unambiguously narrow subsections (A) and (B) to exclude those same types of investments.

Certain Solid State Storage Drives, Stacked Elecs. Components, and Prods. Containing Same, Inv. No. 337-TA-1097, Comm’n Op. at 8 (June 29, 2018) (“*Storage Drives*”); *see also, e.g., Certain Marine Sonar Imaging Devices, Including Downscan and Sidescan Devices, Prods. Containing the Same, and Components Thereof*, Inv. No. 337-TA-921, Comm’n Op. at 57-64 (Jan. 6, 2016) (“*Sonar Imaging Devices*”).

Public Version

There is no mathematical threshold test or a “rigid formula” for determining whether a domestic industry exists. *Certain Male Prophylactic Devices, Inc.*, Inv. No. 337-TA-292, Comm’n Op. at 39, USITC Pub. 2390 (June 1991) (“*Male Prophylactic Devices*”). However, to determine whether investments are “significant” or “substantial,” the actual amounts of a complainant’s investments or a quantitative analysis must be performed. *Lelo Inc. v. Int’l Trade Comm’n*, 786 F.3d 879, 883-84 (Fed. Cir. 2015). Even after *Lelo*, which requires some quantification of a complainant’s investments, there is still no bright line as to a threshold amount that might satisfy an economic industry requirement.

It is the complainant’s burden to show by a preponderance of evidence that each prong of the domestic industry requirement is satisfied. *Certain Prods. Containing Interactive Program Guide and Parental Control Tech.*, Inv. No. 337-TA-845, Initial Determination, 2013 WL 3463385, at *14 (June 7, 2013) (“*Interactive Program Guide*”). Moreover, the Commission makes its determination by “an examination of the facts in each investigation, the article of commerce, and the realities of the marketplace.” *Male Prophylactic Devices*, Comm’n Op. at 39 (quoting *Certain Double Sided-Floppy Disk Drives and Components Thereof*, Inv. No. 337-TA-215, Comm’n Op. at 17, USITC Pub. 1859 (May 1986)).

B. Economic Prong Overview

It is a finding of this decision that Complainant failed to satisfy the “technical prong” of the domestic industry requirement with respect to all the Asserted Patents. (See Sections VII.C and VII.C, *supra*.) Because the alleged DI Products are not articles protected by the Asserted Patents, by operation of law, Complainant cannot satisfy the “economic prong” of the domestic industry requirement, which can only be met by economic activities “with respect to the articles protected by the [asserted] patent.” 19 U.S.C. § 1337(a)(3). In the event the Commission

disagrees with this finding, an alternative analysis with respect to Complainant's domestic activities is provided below.

If the Commission determines that Complainant has satisfied the technical prong of the DI requirement for one or more of the Asserted Patents, Complainant has proven that a domestic industry exists through the domestic activities and investments of its licensee, Samsung Electronics America ("Samsung" or "SEA"). Complainant has proven that a domestic industry exists and has thus satisfied the economic prong of the DI requirement under Subsections 337(a)(3)(A) and (B). Record evidence in this Investigation demonstrates that Samsung made significant investment in plant and equipment, and significant employment of labor and capital, with respect to the Samsung Galaxy DI Products ("DI Products" or "Galaxy DI Products").

C. The Samsung DI Products Are the Proper Relevant "Article"

Complainant relied upon the DI Products, i.e., the identified Samsung Galaxy phones, for purposes of determining its domestic industry expenditures. (CPBr. at 73; CBr. at 124.). Respondents contended that the relevant article is the [REDACTED] (System-on-chip), and not the DI Products that contain the SoCs. (See RPBr. at 51; RRBr. at 58.). Respondents' contention is not persuasive for the following reasons.

As an initial matter, the articles defined by the Notice of Institution of Investigation are LTE- and 3G-compliant cellular communications devices, such as smartphones. (Doc. ID No. 658973 (Oct. 16, 2018), Notice of Institution of Investigation at 2 (stating "the plain language description of the accused products or category of accused products, which defines the scope of the investigation, is 'personal electronic devices that are compliant with the LTE and/or 3G 3GPP specification, and which enable LTE and/or 3G data transfer and communications"). The DI Products enable LTE and 3G data transfer and communications, which Respondents did not

Public Version

770, Comm'n Op. at 66-67 (Oct. 28, 2013) (considering whether the patented technology is sold as a separate entity or article of commerce and whether it is an essential component of the downstream product) (“*Video Game Systems*”); see also *Certain Double-Sided Floppy Disk Drives and Components Thereof*, Inv. No. 337-TA-215, Comm'n Op. at 17-18 (Oct. 15, 1985); *Certain Male Prophylactic Devices*, Inv. No. 337-TA-546, Comm'n Op. at 42 (Aug. 1, 2007)).

Samsung invests in U.S. [REDACTED]

[REDACTED]. The described activities in which Samsung has invested in the United States are related to the salability and proper functioning of the Galaxy DI Products. Therefore, they are qualifying activities pursuant to Commission precedent that applies to the economic prong analysis. *Certain Semiconductor Devices, Semiconductor Device Packages, and Prods. Containing Same*, Inv. No. 337-TA-1010, Order No. 73 at 5 (Mar. 2, 2017) (noting that the “[m]ore important’ inquiry is whether the alleged domestic industry activities ‘have a direct relationship to exploitation of the patented technology’”) (quoting *Video Game Systems*, Inv. No. 337-TA-770, Comm'n Op. at 67) (“*Semiconductor Devices*”); see also *Certain Table Saws Incorporating Active Injury Mitigation and Components Thereof*, Inv. No. 337-TA-965, Order No. 10 at 17 (Mar. 22, 2016) (“without SawStop’s R&D, logistical support, technical service, administration, and sales and marketing, SawStop would be unable to have successfully exploited the patents underlying its Domestic Industry Product”).

Respondents asserted that unlike *Air Mattress Systems*,⁸⁵ which Complainant cited, the

⁸⁵ *Certain Air Mattress Systems, Components Thereof and Methods of using the Same*, Inv. No. 337-TA-971, Comm'n Op. at 43 (June 20, 2017) (“*Air Mattress Systems*”).

Public Version

facts here do not present “circumstances [where] the realities of the marketplace require a modification of the [general] principle [to] . . . extend the relevant ‘industry’ to a downstream article incorporating the patented component” because [REDACTED] separately sells the [REDACTED] SoCs to Samsung, and “are an article of commerce distinct from the Galaxy Products.” (RRBr. at 59 (citing *Air Mattress Systems*, Inv. No. 337-TA-971, Comm’n Op. at 43).).

Even assuming, *arguendo*, that the [REDACTED] SoCs constitute an article of commerce, that alone is not dispositive. As the Commission pointed out in *Video Game Systems*, whether the patented article is sold as a separate entity or article of commerce is merely one factor that may be considered when determining what constitutes the patented article.

It may happen that the patented article is not itself an actual article of commerce, but is physically incorporated as a component in a downstream article of commerce. In such circumstances, the Commission *may, depending on the facts of each particular investigation*, extend the relevant “industry” to a downstream article of commerce incorporating the patented component.

Video Game Systems, Inv. No. 337-TA-770, Comm’n Op. at 66 (emphases added) (internal citation omitted).

Additional factors include whether the patented article is an “essential component” of the downstream product, as is the case here. (Tr. (Lathrop) at 1797:20-1798:10, 1798:14-17

(testifying that [REDACTED] [REDACTED]). *Graphics Processors*, Inv. No. 337-TA-1099, Order No. 16 at *2

(“Relevant factors *may* include whether the patented technology is sold as a separate entity or article of commerce and whether it is an essential component of the downstream product.”)

(emphasis added) (quoting *Semiconductor Devices*, Inv. No. 337-TA-1010, Order No. 73 at 5).

Accordingly, for the reasons discussed above, the Galaxy DI Products are the proper relevant “article.”

D. Complainant Has Satisfied the Economic Prong of the Domestic Industry Requirement Under Subsections 337(a)(3)(A) and (B)

1. Complainant's Investments in Plant and Equipment Are Significant

Samsung made and continues to make significant domestic investments in the Galaxy DI Products in the form of facility and equipment costs (in relation to activities pertaining to [REDACTED], for instance). Samsung is headquartered in Ridgefield Park, New Jersey and has [REDACTED] [REDACTED]. (CX-0187C; CX-0188C; CX-0184C at ¶ 7.). Additionally, Samsung has [REDACTED] [REDACTED]. (Tr. (Timothy Sheppard)⁸⁶ at 1373:9-12.). To prove significant investments under Subsection 337(a)(3)(A), Complainant relied upon two (2) general categories of expenditures: (i) [REDACTED] expenditures; and (ii) [REDACTED]. (CX-0187C; CX-0188C; CPBr. at 80.).

Mr. Joshua Lathrop, Complainant's expert witness on the economic requirement of domestic industry, analyzed Samsung's [REDACTED] using both a revenue-based methodology and a unit sales-based methodology for an 18-month and an 8-month time period within range of the September 13, 2018 filing date of the Complaint. (Tr. (Lathrop) at 1760:4-7, 1760:15-1762:1; CX-1433C.). *See Certain Mobile Device Holders and Components Thereof*, Inv. No. 337-TA-1028, Comm'n Op. at 18 (Mar. 22, 2018) (recognizing as permissible

⁸⁶ When he testified during the Hearing on September 18, 2019, Mr. Timothy Sheppard was Vice President of Logistics at Samsung Electronics America. (Tr. (Sheppard) at 1357:2-4, 13-14.). Complainant identified Mr. Sheppard as a fact witness to testify about Samsung Electronics America's domestic industry. (CPSt. at 3.).

the use of allocation methodologies appropriate to the complainant's circumstances).

Mr. Lathrop opined that under a revenue-based methodology, [REDACTED] and [REDACTED] are attributed to the Samsung Galaxy DI Products for the 18-month and 8-month time periods, respectively. (Tr. (Lathrop) at 1764:16-1768:24; CX-1459C (showing a total of [REDACTED], for 18-month time period based on revenue allocation); CX-1474C (showing a total of [REDACTED], for 18-month time period based on revenue allocation); *see also* CX-1464; CX-1495C; CX-1500C; CX-1510C.).

Samsung's facilities and capital expenditures are summarized below in Table No. 11.

Table No. 11: Samsung's DI Investments Allocated by Revenue



(CDX-0007C.0002 (citing CX-1459C; CX-1464; CX-1474C; CX-1495C; CX-1500C; CX-1510C.).

Each of the figures in Table No. 11 includes expenses related to [REDACTED]

[REDACTED]

[REDACTED]. For example, the [REDACTED] 18-month expenditure includes a [REDACTED]

[REDACTED] expenditure allocated to the Galaxy DI Products and a [REDACTED]

[REDACTED] expenditure allocated to the Galaxy DI Products, as shown below in

Table Nos. 12 and 13. (See CX-1459C; CX-1474C.).

**Table No. 12: Samsung's ██████████ Expenditures by Revenue Allocation
(18 Months)**



(CX-1459C (annotated).).

**Table No. 13: Samsung's Expenditures for [REDACTED]
by Revenue Allocation (18 Months)**



(CX-1474C (annotated)).

Similarly, the [REDACTED] 8-month expenditure includes a [REDACTED]
[REDACTED] capital expenditure allocated to the Galaxy DI Products and a [REDACTED]
[REDACTED] expenditure allocated to the Galaxy DI Products, as shown below in
Table Nos. 14 and 15. (See CX-1495C; CX-1510C.).

Table No. 14: Samsung's [REDACTED] Expenditures by Revenue Allocation (8 Months)



(CX-1495C (annotated)).

Table No. 15: Samsung's Expenditures for [REDACTED] by Revenue Allocation (8 Months)



(CX-1510C (annotated)).

Under the unit sales allocation methodology, Complainant's expert attributed

[REDACTED] and [REDACTED] to the Galaxy DI Products for the 18-month and 8-month time

periods, respectively. (CX-1459C (showing a total of [REDACTED] for 18-month time period based on unit allocation); CX-1479C (showing a total of [REDACTED], for 18-month time period based on unit allocation).). Complainant's expert's unit-based allocations are summarized below in Table No. 16.

Table No. 16: Samsung's DI Investments Allocated by Unit Sales



(CDX-0007C.0004 (citing CX1459C; CX-1469C; CX-1479C; CX-1495C; CX-1505C; CX-1515C).).

Each of the figures identified in Table No. 16 includes expenses related to [REDACTED] that Complainant's expert has allocated to the Galaxy DI Products and expenses. For instance, the [REDACTED] 18-month expenditure based on this approach includes a [REDACTED] expenditure allocated to the Galaxy DI Products and a [REDACTED] expenditure allocated to the Galaxy DI Products, as shown below in Table Nos. 17 and 18. (See CX-1459C; CX-1479C.).

**Table No. 17: Samsung's [REDACTED] Expenditures by Unit Sales Allocation
(18 Months)**



(CX-1459C (annotated)).

**Table No. 18: Samsung's Expenditures for [REDACTED]
by Unit Sales Allocation (18 Months)**



(CX-1479C (annotated)).

Likewise, the [REDACTED] 8-month expenditure includes a [REDACTED] [REDACTED] expenditure that is allocated to the Galaxy DI Products and a [REDACTED] [REDACTED] expenditure allocated to the Galaxy DI Products, as shown below in Table Nos. 19 and 20. (See CX-1495C; CX-1515C.).

Table No. 19: Samsung's [REDACTED] Expenditures by Unit Sales Allocation (8 Months)

A large rectangular area of the document is completely redacted with a solid grey fill, obscuring the content of Table No. 19.

(CX-1495C (annotated)).

Table No. 20: Samsung's Expenditures for [REDACTED] by Unit Sales Allocation (8 Months)

A large rectangular area of the document is completely redacted with a solid grey fill, obscuring the content of Table No. 20.

Public Version

(CX-1515C (annotated)).

The weight of the evidence supports a finding that Complainant has met its burden of proving that the expenditures in support of Subsection 337(a)(3)(A) are significant from both a quantitative and a qualitative standpoint. Samsung's [REDACTED] of investments and expenditures allocated to the Galaxy DI Products are quantitatively significant. (See, e.g., CX-1474C.). For example, Samsung's [REDACTED] [REDACTED]. (See, e.g., *id.*; see also Tr. (Lathrop) at 1810:5-23, 1810:24-1811:16.). Respondents contended that this type of domestic comparison is “arbitrary” and does not demonstrate “any ‘significant increase or attribution’ in the DI Products by virtue of the limited domestic activities [Samsung’s] [REDACTED] division performs.” (RPBr. at 53-54.). However, the Commission has long held that a “determination on the economic prong is not made according to any rigid formula—there is no mathematical threshold test.” *Certain Male Prophylactic Devices*, USITC Pub. 4005, Inv. No. 337-TA-546, Comm’n Determination at 19 (May 2008) (emphasis added).

To the extent that Respondents argued that the comparative analysis must involve a comparison of domestic to foreign investments, Staff correctly noted that the Commission has not mandated such a comparison, but rather identified it one of the factors that the Commission considers in its analysis regarding significance. See *Certain Encapsulated Integrated Circuit Devices and Prods. Containing Same*, Inv. No. 337-TA-501, Comm’n Op. at 34 (April 28, 2014) (Commission “reiterat[ing] that the comparative analysis of domestic to foreign economic activity under criteria (A) and (B) is not mandatory, but rather is one of the factors the Commission can utilize in its analysis”). Qualitatively, the evidence demonstrates that the [REDACTED]

expenditures are important to the Galaxy DI Products because these expenditures ensure that the Galaxy DI Products are [REDACTED].

For these reasons, Complainant has met its burden and proven that its investments in plant and equipment for the Galaxy DI Products through Complainant's licensee Samsung are significant.

2. Complainant's Investments in Employment of Labor and Capital Are Significant

Samsung made and continues to make significant domestic investments in labor and capital to support the Galaxy DI Products. Complainant relied upon Samsung's investments in salaries, benefits, and bonuses directed to Samsung's employment of labor, which includes

[REDACTED]

[REDACTED].⁸⁷ (CPBr. at 82-83; CBr. at 133.). As he did for Samsung's investments in plant and equipment, Mr. Lathrop performed both revenue and unit sales-based allocation methods.

Under a revenue-based allocation methodology, Mr. Lathrop attributed [REDACTED] (shown in CX-1464C) and [REDACTED] (shown in CX-1500C) in expenditures related to labor costs to the Galaxy DI Products for the 18-month and 8-month time periods, respectively, as illustrated below in Table Nos. 21 and 22. (CDX-0007C.0002; CX-1459C; CX-1464C; CX-1474C; CX-1495C; CX-1500; CX-1505C.).

⁸⁷ [REDACTED] (Tr. (Lathrop) at 1727:22-1729:16.).
[REDACTED] (*Id.*).

Table No. 21: Samsung's Labor Costs by Revenue Allocation (18 Months)

A large rectangular area that has been completely redacted with a solid grey fill, obscuring the data for Table No. 21.

(CX-1464C (annotated)).

Table No. 22: Samsung's Labor Costs by Revenue Allocation (8 Months)

A large rectangular area that has been completely redacted with a solid grey fill, obscuring the data for Table No. 22.

(CX-1500C (annotated)).

Under a unit sales-based allocation methodology, Mr. Lathrop attributed [REDACTED] [REDACTED] in expenditures related to labor costs to the Galaxy DI Products for the 18-month and 8-month time periods, respectively. (See CX-1469C; CX-1505C.).

Table No. 23: Samsung's Labor Costs by Unit Sales Allocation (18 Months)

A large gray rectangular area representing a redacted table. The table content is completely obscured by a solid gray block.

(CX-1469C (annotated)).

Table No. 24: Samsung's Labor Costs by Unit Sales Allocation (8 Months)



(CX-1505C (annotated)).

The weight of the evidence supports a finding that Samsung's expenditures in support of Subsection 337(a)(3)(B) are significant from both a quantitative and a qualitative standpoint. For instance, quantitatively, Samsung's [REDACTED] of investments and expenditures over an 18-month period allocated to the Galaxy DI Products are significant in comparative terms. (See CX-1464C.). The labor expenditures for the above-identified R&D division represent [REDACTED] of labor expenditures across all SEA mobile divisions. (See, e.g., CX-1469C.).

Additionally, Mr. Lathrop and Samsung provided evidence that the number of workers employed (including contracted and temporary workers) in the United States in Samsung's

[REDACTED]

[REDACTED], and are allocated solely to the Galaxy DI Products. (See, e.g., CX-0192C.). Similarly, Samsung [REDACTED]
[REDACTED]
[REDACTED]
[REDACTED],⁸⁹ which also are allocated to the

Galaxy DI Products as follows:

1. [REDACTED]
[REDACTED]. (CX-0192C.)
2. [REDACTED]
[REDACTED]. (CX-0192C.).
3. [REDACTED]
[REDACTED]. (CX-1442C.).
4. [REDACTED]
[REDACTED]. (CX-1443C.).

For the foregoing reasons, Complainant has met its burden and proven that its

⁸⁸ Complainant described [REDACTED]
[REDACTED] (Tr. (Lathrop) at 1727:22-1729:16; CBr. at 127.).
[REDACTED] (Tr. (Sheppard) at 1397:5-10.).
[REDACTED] (*Id.* at 1396:22-25, 1399:14-20.).

⁸⁹ Complainant described [REDACTED]
[REDACTED] (Tr. (Lathrop) at 1727:16-21; CDX-0007C.0007.).
[REDACTED] (Tr. (Lathrop) at 1729:17-1730:11; CDX-0007C.0007.).

investments in the employment of labor and capital are significant.

E. Complainant Has Not Satisfied the Economic Prong of the Domestic Industry Requirement Under Subsection 337(a)(3)(C)

Complainant alleged that Samsung has made and continues to make substantial investment in the exploitation of the Asserted Patents. (CBr. at 138-39.). However, Complainant did not meet its burden regarding this allegation because Mr. Lathrop failed to demonstrate persuasively that a “nexus” exists between the Asserted Patents and the alleged investments upon which he relied to satisfy Subsection 337(a)(3)(C). (*See, e.g.*, Tr. (Lathrop) at 1778:1-15.). Mr. Lathrop based his opinion on the assumption that the Galaxy DI Products practice the Asserted Patents.

Q. Why do you believe a nexus has been shown, or what assumptions have you made?

A. Well, the assumption that I’ve made there is that -- first of all, let me say I understand that there -- when an article-based approach has been performed, that a ready inference can be made that subparagraph (c) expenses may -- made by an article approach, if it’s true that the DI products embody the patent technology. So I think-- I’m not here on a technical basis, but if that’s true, then it -- would be possibly something. If that’s not shown to be true, then I would probably look at it as subparagraph (a) and (b).

(Tr. (Lathrop) at 1778:1-15.).

However, since it is a finding of this decision that the Galaxy DI Products do not satisfy the technical prong of the domestic industry requirement, Mr. Lathrop’s “assumption” carries no weight. (*See* Section VIII.C, *supra.*). Nevertheless, the evidence supports a finding that Complainant has met the domestic industry requirement under Subsections 337(a)(3) (A) and B for the reasons discussed above. *See Marine Sonar Imaging Devices, Including Downscan and Sidescan Devices, Prods. Containing the Same, and Components Thereof*, Inv. No. 337-TA-586, Comm’n Op. at 13 (May 16, 2008) (“The satisfaction of any one of these criteria (i.e.,

subparagraph (A), subparagraph (B), or subparagraph (C)) will satisfy the economic prong.”).

Accordingly, should the Commission determine that Samsung’s DI Products practice the Asserted Patents, and that INVT has satisfied the technical prong of the domestic industry requirement, Complainant has presented virtually un rebutted evidence that it satisfies the economic prong of the domestic industry requirement under Subsections 337(a)(3)(A) and (B).

X. RESPONDENTS’ AFFIRMATIVE DEFENSES

A. Overview

Each of the Respondents, Apple, HTC and ZTE individually asserted various Affirmative Defenses in their Responses to the Complaint and NOI, which were not necessarily in the same order. (*See* Apple Resp. at 47-54, ¶¶ 16.1-16.31; HTC Resp. at 30-36, ¶¶ 6-24; ZTE Resp. at 58-62, ¶¶ 1-12.).⁹⁰

⁹⁰ Apple’s Response identified the following Affirmative Defenses: First Affirmative Defense (Non-Infringement); Second Affirmative Defense (Invalidity); Third Affirmative Defense (Lack of Domestic Industry); Fourth Affirmative Defense (Not in the Public Interest); Fifth Affirmative Defense (Estoppel); Sixth Affirmative Defense (License, Waiver, and/or Patent Exhaustion); Seventh Affirmative Defense (Breach of FRAND Obligations); Eighth Affirmative Defense (Equitable Estoppel/Waiver); Ninth Affirmative Defense (Unclean Hands); Tenth Affirmative Defense (Lack of Standing); Eleventh Affirmative Defense (Breach of Non-Disclosure Agreement); and Twelfth Affirmative Defense (No Violation of § 1337). (Apple’s Resp. at 47-54.).

HTC’s Response identified the following Affirmative Defenses: First Affirmative Defense (Invalidity); Second Affirmative Defense (Non-Infringement); Third Affirmative Defense (Relief Not in the Public Interest); Fourth Affirmative Defense (Lack of Domestic Industry); Fifth Affirmative Defense (Unclean Hands); Sixth Affirmative Defense (License, Waiver and/or Exhaustion); Seventh Affirmative Defense (Estoppel); Eighth Affirmative Defense (Unenforceability); Ninth Affirmative Defense (Breach of FRAND Obligations); Tenth Affirmative Defense (Lack of Standing); and Eleventh Affirmative Defense (No Violation of Section 337 of the Tariff Act). (HTC’s Resp. at 30-36.).

ZTE’s Response identified the following Affirmative Defenses: First Affirmative Defense (Non-Infringement); Second Affirmative Defense (Invalidity); Third Affirmative Defense (Lack of Domestic Industry); Fourth Affirmative Defense (Contrary to Public Interest); Fifth Affirmative Defense (Unclean Hands); Sixth Affirmative Defense (License, Waiver and/or Exhaustion); Seventh Affirmative Defense (Prosecution History Estoppel); Eighth Affirmative Defense (Unenforceability); Ninth Affirmative Defense (Breach of FRAND Obligations); and Tenth Affirmative Defense (No Violation of Section 337

Public Version

In their joint Pre-Hearing Brief, Respondents raised only four Affirmative Defenses: (1) License, Waiver, and/or Exhaustion; (2) Unclean Hands; (3) Estoppel/Waiver; and (4) Breach of Non-Disclosure Agreement (“NDA”).⁹¹ (RPBr. at 83-89.). In their joint Initial Post-Hearing Brief, Respondents dropped Breach of NDA as an Affirmative Defense and raised only the following Affirmative Defenses: (1) License, Waiver, and/or Exhaustion; (2) Unclean Hands; (3) Estoppel/Waiver. (RBr. at 84-89.).

Any of Respondents’ Affirmative Defenses that are not discussed below as Affirmative Defenses (e.g., Breach of NDA) have been waived or abandoned pursuant to Ground Rules 7.2 and/or 10.1.⁹²

of the Tariff Act). (ZTE’s Resp. at 58-62.).

Moreover, Respondents Apple and HTC adopted and incorporated by reference the affirmative defenses of the other Respondents. (Apple’s Resp. ¶ 16.2; HTC’s Resp. at 30.).

⁹¹ It appears that many “Affirmative Defenses” identified in the above-mentioned Responses filed by Apple, HTC, and ZTE, such as non-infringement, invalidity, and lack of domestic industry, are not Affirmative Defenses at all, but rather generic defenses. Black’s Law Dictionary defines an affirmative defense as an “assertion of facts and arguments that, if true, will defeat the plaintiff’s or prosecution’s claim, even if all the allegations in the complaint are true.” Black’s Law Dictionary (11th ed. 2019).

⁹² Apple’s waived or abandoned Affirmative Defenses are: First Affirmative Defense (Non-Infringement); Second Affirmative Defense (Invalidity); Third Affirmative Defense (Lack of Domestic Industry); Fourth Affirmative Defense (Not in the Public Interest); Tenth Affirmative Defense (Lack of Standing); Eleventh Affirmative Defense (Breach of Non-Disclosure Agreement); and Twelfth Affirmative Defense (No Violation of § 1337).

HTC’s waived or abandoned Affirmative Defenses are: First Affirmative Defense (Invalidity); Second Affirmative Defense (Non-Infringement); Third Affirmative Defense (Relief Not in the Public Interest); Fourth Affirmative Defense (Lack of Domestic Industry); Tenth Affirmative Defense (Lack of Standing); and Eleventh Affirmative Defense (No Violation of Section 337 of the Tariff Act).

ZTE’s waived or abandoned Affirmative Defenses are: First Affirmative Defense (Non-Infringement); Second Affirmative Defense (Invalidity); Third Affirmative Defense (Lack of Domestic Industry); Fourth Affirmative Defense (Contrary to Public Interest); Seventh Affirmative Defense (Prosecution History Estoppel); and Tenth Affirmative Defense (No Violation of Section 337 of the Tariff Act).

B. Respondents' Patent Exhaustion Affirmative Defense Is Not Supported⁹³

According to Respondents, INVT's rights in the Asserted Patents have been exhausted⁹⁴ but only for Accused Products that include [REDACTED] components.⁹⁵ (RPBr. at 83-84 (citing JX-0009C.20-21 § 8.3); *see also* RBr. at 83-88.).⁹⁶ According to that premise, in this Investigation, INVT had no right to assert infringement against Accused Products with [REDACTED] modems. Staff disagreed with Respondents. (SBr. at 77 (“But Respondents’ position regarding patent exhaustion is fatally flawed.”)).

The legal standard for patent exhaustion holds that: “The authorized sale of an article that

⁹³ Patent Exhaustion is Apple's Sixth Affirmative Defense, HTC's Sixth Affirmative Defense, and ZTE's Sixth Affirmative Defense.

⁹⁴ Respondents jointly filed a Motion for Summary Determination on Respondents' Patent Exhaustion Affirmative Defense (“Patent Exhaustion MSD”). (Motion Docket No. 1138-023 (Apr. 8, 2019)). That Motion was denied during the August 7, 2019 Teleconference in which decisions on MILs were also given to the Parties. (August 7, 2019 Tel. Tr. at 25:14-18 (Doc. ID No. 690689)). Respondents' Patent Exhaustion MSD was denied because, at that time, there were [REDACTED] documents that either were redacted inappropriately, or there were [REDACTED] documents that INVT had not produced. INVT was ordered to produce unredacted [REDACTED] documents and missing documents in response to Respondents' MIL No. 2 to produce certain documents and to preclude others. (*See* Section II.A, *supra*).

⁹⁵ The Private Parties' experts confirmed that, with the Accused Products with [REDACTED] components, the functionality accused of infringing the asserted claims is all contained within the [REDACTED] components, specifically the baseband modems. (Tr. (Nettleton) at 602:11–604:2; Tr. (Wicker) at 1467:15–25; RDX-0005C.0030; Tr. (Vojcic) at 782:10–24; CDX-0005C.0011.).

⁹⁶ It appears that only the Apple iPhone XS A1920 representative product incorporates something other than a [REDACTED] modem. (CX-1236C.0001 ([REDACTED])). The iPhone XS A1920 is representative of: iPhone 7 A1778; iPhone 7 Plus A1784; iPhone 8 A1905; iPhone 8 Plus A1897; iPhone X A1901; iPhone XR A1984; iPhone XS Max A1921; iPad Pro 11” A2013; iPad Pro 12.9” A2014; iPad Air (2019) A2123; iPad Mini (2019) A2124; Apple Watch Series 4 A1975; and Apple Watch Series 4 A1976. (Representative Product Stipulation at 1-2.).

The remaining representative accused products and the products they represent incorporate [REDACTED] modems and thus would be implicated by Respondents' patent exhaustion defense in the event it were successful, which it is not. The Apple iPhone 8 incorporates a [REDACTED] LTE modem. (CX-1236C-0013.). The HTC U11 incorporates a [REDACTED] LTE modem. (CX-1255C.0016-17, 50-51.). The ZTE Max XL incorporates a [REDACTED] chipset with an [REDACTED] LTE modem. (CX-1227 at 92-95.).

Public Version

substantially embodies a patent exhausts the patent holder’s rights and prevents the patent holder from invoking patent law to control postsale use of the article.” (See RBr. at 84 (quoting *Quanta Comp., Inc. v. LG Elecs., Inc.*, 553 U.S. 617, 638 (2008).). Noting a key Supreme Court holding, Respondents quoted: “[E]xhaustion is rooted in the “common law principle against restraints on alienation” and “reflects the principle that, when an item passes into commerce, it should not be shaded by a legal cloud on title as it moves through the marketplace” (quoting *Impression Prods., Inc. v. Lexmark Int’l, Inc.*, 137 S. Ct. 1523, 1531, 1534 (2017)(“*Lexmark*”); see also “The limit functions automatically: When a patentee chooses to sell an item, that product ‘is no longer within the limits of the monopoly’ and instead becomes the ‘private, individual property’ of the purchaser.” (RBr. at 84, (citing *Lexmark*. at 1531.)). Respondents also quoted the following principle from *Lexmark*, which explains:

Respondents argued that principles of *Quanta and Lexmark* apply here to the authorized sales by a patentee’s licensees:

So long as a licensee complies with the license when selling an item, the patentee has, in effect authorized the sale. That licensee’s sale is treated, for purposes of patent exhaustion, as if the patentee made the sale itself. The result: The sale exhausts the patentee’s rights in that item.

Lexmark at 1535.

Respondents reflected that the Federal Circuit has also made its own precedential statement on patent exhaustion: “[T]he Federal Circuit has “explained that a non-exclusive patent license is equivalent to a covenant not to sue.” (RBr. at 87 (citing *TransCore, LP v. Elec. Transaction Consultants Corp.*, 563 F.3d 1271, 1275 (Fed. Cir. 2009); see also RBr., *id.* (citing “A product sale is therefore ‘authorized’ when a patent holder surrenders his right to exclude— via a license agreement or covenant not to sue—and thereby immunizes the seller of that product

Public Version

from infringement liability;”) (see also *id.* (citing *High Point SARL v. TMobile USA, Inc.*, 640 F. App’x 917, 929 (Fed. Cir. 2016) (“On this point *Quanta* is clear: The only issue relevant to patent exhaustion is whether [a licensee’s] sales were authorized, not whether [the patentee] and [licensee] intended, expressly or impliedly, for the covenant to extend to [the licensee’s] customers); RBr. at 86 (citing *TransCore*, 563 F.3d at 1277 (quoting *Quanta*, 553 U.S. at 637)).

Applying the Supreme Court and Federal Circuit authority, Respondents argued that [REDACTED] allegedly was authorized through agreements with Panasonic, INVT’s predecessor in interest to the Asserted Patents, to sell modem chipsets directly to Respondents. (RBr. at 84-85.). Therefore as they argued, Respondents’ affirmative patent exhaustion defense is based on specific provisions found in a Patent Purchase Agreement (“PPA”) between Panasonic and Inventergy, and also by a separate agreement between [REDACTED] [REDACTED].⁹⁷ (JX-0009 (PPA); RX-1474C ([REDACTED])).⁹⁸

Respondents argued that the PPA provides that [REDACTED] [REDACTED] [REDACTED] that were included in Appendix E to the PPA. (See RBr. at 84 (citing JX-0009C.0020–21.)) The

⁹⁷ According to INVT, the patent exhaustion issue originates from a third agreement that Respondents ostensibly failed to mention: a [REDACTED] (JX-0009C.0020; CRBr. at 41-42.). According to INVT, the [REDACTED] [REDACTED]. (CRBr. at 41-42.). INVT also asserted and argued that the [REDACTED] [REDACTED] (CRBr. at 42 (citing JX-0009C, RX-1474C (headings “A,” “B,” and “C”)).

⁹⁸ Although not explicitly stated, Respondents’ patent exhaustion defense is also premised upon the assertion that Inventergy transferred its rights and obligations under the PPA and Qualcomm Terms to INVT as part of the Patent Assignment Agreement. (JX-0013 (Patent Assignment Agreement) at 1.).

[REDACTED]
[REDACTED]. (*Id.* at 85 (citing RX-2381C (Beyers⁹⁹ Dep. Tr.) at 221:10–18, 221:24–222:7, 223:4–7; RX-1474C.)).

The [REDACTED] provide:

[REDACTED]

(*See id.* at 85 (citing RX-1474C.0001)).

According to Respondents’ interpretation, Exhibit B to the [REDACTED] lists the Asserted Patents. (*Id.* at 84-84 (citing RX-1474C at 2–4)). As Respondents also argued:

[REDACTED] states that [REDACTED]

[REDACTED]

[REDACTED]¹⁰⁰ (*Id.* at 85-86 (citing RX-1474C at 8)). [REDACTED]

[REDACTED]

[REDACTED]. (*Id.* at 85 (citing RX-1474C at 5)).

Respondents argued that the proper interpretation of, and takeaway from, the referenced

⁹⁹ When he was deposed on January 11, 2019, Mr. Joseph Beyers was the CEO of Inventergy Inc. He was offered to testify on behalf of INVT with respect to his knowledge of Inventergy’s purchase of the Asserted Patents from Panasonic, the Asserted Patent’s encumbrances, and Inventergy’s attempts to license the Asserted Patents. (RPSt. at 4.).

¹⁰⁰ According to INVT, “Respondents have failed to meet their burden to show the specific version of the [REDACTED] (CRBr. at 45.).

Public Version

agreements is that Qualcomm was authorized to sell components practicing the Asserted Patents to Respondents for inclusion in the Accused Products. (*Id.* at 88.). Therefore, according to Respondents’ interpretations of the various agreements, INVT has exhausted its patent rights with respect to those sales consistent with the holdings of *Quanta* and *Lexmark, supra*.

INVT rebutted Respondents’ interpretation of the various agreements. INVT argued that “based on a plain reading of the documents at issue, the only reasonable conclusion is that the

[REDACTED]

[REDACTED]

[REDACTED]¹⁰¹ (CRBr. at 42-43.). According to INVT, a

[REDACTED] (and thereby give rise to a defense of

patent exhaustion), the covenant must be unconditional and “without apparent restriction or limitation . . . authorize all acts that would otherwise be infringement: making, using, offering for sale, selling, or importing.” (*See* CBr. at 41 (citing *TransCore*, 563 F.3d at 1276 (only “an unconditional covenant not to sue” exhausts a patent (emphasis added))). A licensee can provide a conditional covenant and “limit authorization to, for example, ‘making’ or ‘using.’”)).

¹⁰¹ Order No. 51 granted Respondents’ MIL No. 2 that precluded INVT from arguing that the covenant not to assert does not extend to [REDACTED] “sales.” (Order No. 51 at 3 (Sept. 10, 2019)). However, INVT moved for reconsideration of that ruling (“Reconsideration Motion”). (Motion Docket No. 1138-056 (Sept. 20, 2019)). Respondents filed an opposition to INVT’s Reconsideration Motion (“Opposition”). (Doc. ID No. 689104 (Sept. 24, 2019)). Order No. 63, issued on February 18, 2020, resolved that motion in Respondents’ favor.

During discovery, [REDACTED] (Ex. 133 to INVT’s complaint identifies the [REDACTED]). (*Id.*; *see also* JX-0015C.0002 n.1.). INVT’s Reconsideration Motion also explained that INVT’s timely-served interrogatory responses distinguished between the rights granted (i.e. to make, use, and import) and not granted (i.e. to sell), where [REDACTED]. (Reconsideration Mot. at 2 (citing RX-1717C.0003-04)).

Public Version

Specifically, INVT pointed out that [REDACTED]

[REDACTED] (CRBr. at 43-44 (citing JX-0009C-0035; RX-1474C.0005.)). Consistent with its argument, INVT also asserted that [REDACTED]

[REDACTED] (*Id.* at 43-44.). According to INVT, subsection 8.1.1.2 [REDACTED].

Notwithstanding the myriad and seemingly competing applicable agreements and provisions identified, and absent a definitive identification of the [REDACTED], it is clear that Respondents' patent exhaustion Affirmative Defense is not supported, but not necessarily because of the competing interpretations of the agreements at issue. As explained by Staff, a required element of patent exhaustion is that the article at issue must substantially embody an asserted patent. (SBr. at 77 (citing *Quanta Comp*, 553 U.S. at 638).); *see JVC Kenwood Corp. v. Nero, Inc.*, 797 F.3d 1039, 1046 (Fed. Circ. 2015) (“‘Substantial embodiment’ is established if (1) the only reasonable and intended use of the article is to practice the allegedly exhausted patent; and (2) the article embodies the essential or inventive features of the allegedly exhausted patent.”). Yet, as explained in the essentiality and infringement Sections VII.A & B, *supra*, and in accord with Staff and Respondents' interpretations of the provisions of the agreements that INVT made available, Respondents have argued successfully that the Accused Products do not substantially embody an Asserted Patent and that the Accused Products (in general and, for present purposes, those containing [REDACTED] components) do not infringe. (SBr. at 77-78 (“in direct contradiction to its non-infringement theories, Respondents now argue that the [REDACTED] components ‘substantially embody the

asserted claims.”); RRBr. at 8-36.).

However, notwithstanding the Parties’ disagreements over contract interpretations, because the Accused Products, let alone those that contain [REDACTED] components, do not practice any asserted claim of any of the Asserted Patents, Respondents’ Affirmative Defense of patent exhaustion as based on its Patent Exhaustion is unavailing. By operation of law and the findings of non-infringement, Respondent’s Affirmative Defense of Patent Exhaustion does not apply and is largely irrelevant to this decision. Staff agreed. (SBr. at 78 (“Respondents’ patent exhaustion defense is without merit”).).

C. Respondents’ Affirmative Defense of Unclean Hands Defense Is Not Applicable

The Federal Circuit recently reiterated the governing legal standard that applies to the equitable defense of “unclean hands:” “misconduct” of a party seeking relief “has immediate and necessary relation to the equity that he seeks in respect of the matter in litigation,” i.e., “for such violations of conscience as in some measure affect the equitable relations between the parties in respect of something brought before the court.” *Gilead Scis., Inc. v. Merck & Co., Inc.* (“*Gilead*”), 888 F.3d 1231, 1239 (Fed. Cir. 2018) (citing *Keystone Driller Co. v. General Excavator Co.*, 290 U.S. 240, 245 (1933)). The doctrine of unclean hands “closes the doors of a court of equity to one tainted with inequity or bad faith relative to the matter in which he seeks relief, however improper may have been the behavior of the defendant,” and requires that claimants “have acted fairly and without fraud or deceit as to the controversy in issue.” *Precision Instrument Manufacturing Co. v. Automotive Maintenance Machinery Co.*, 324 U.S. 806, 814–15 (1945) (The doctrine of unclean hands “gives wide range to the equity court’s use of discretion in refusing to aid the unclean litigant.”). The Commission has recognized that the

Public Version

doctrine of unclean hands applies in Commission Investigations. *Certain Semiconductor Chips and Prods. Containing Same*, Inv. No. 337-TA-753, Comm'n Op. at 51-55, USITC Pub. 4386 (March 2013) (affirming administrative law judge's finding that unclean hands barred the complainant's claims as to certain patents).

Respondents argued that INVT's "unclean hands" consists of actions in failing to honor its purported FRAND obligations when INVT negotiated with Respondents in 2015 to take licenses to the Asserted Patents, that INVT's improper conduct was so egregious that it *requires* the Commission to deny any relief to INVT if it were to prevail in this Investigation. (RBr. at 88.). Respondents stated: "INVT has repeatedly refused to honor the FRAND commitments to which it is admittedly bound ... and instead has sought exorbitant, non-FRAND rates and initiated litigation seeking injunctive relief to coerce Respondents into taking licenses at non-FRAND rates." (*Id.*). Citing the Federal Circuit's 2018 *Gilead* decision, Respondents characterized INVT's behavior as "misconduct" that "has immediate and necessary relation to the equity that [INVT] seeks in respect to the matter in litigation," i.e., entry of an exclusion order. (*Id.* (citing *Gilead* at 1239).).

INVT vigorously challenged Respondents' argument that INVT did not meet its FRAND obligations.¹⁰² (CRBr. at 47.). INVT argued that Respondents have failed "to introduce any

¹⁰² As will be addressed in a forthcoming filing on public interest, remedy, and bond, INVT and Respondents disagreed whether the ETSI IPR Policy obligates INVT as owner of the Asserted Patents to *negotiate towards* FRAND terms and conditions or, alternately, *to conclude* a license on FRAND terms and conditions. (CBr. at 17-18; RBr. at 58.). Clause 6.1 of the ETSI IPR Policy requires that the patent holder be "prepared to grant irrevocable licenses on fair, reasonable, and non-discriminatory ('FRAND') terms and conditions." (CX-0212-0001-2 (§6.1)). ETSI IPR Policy is governed by French law. (*See* CX-0212.0006; *see also* Tr. (Fages) at 1094:24-1095:18.).

Relying upon the testimony of its French law expert, Dr. Bertrand Fages, INVT argued that it was merely required to "negotiate in good faith toward a FRAND license," and not actually conclude a license on

Public Version

evidence that INVT’s FRAND-related conduct amounts to misconduct” and “do not even cite authority for the proposition that that not meeting one’s FRAND commitments could lead to misconduct or unclean hands[.]” (*Id.*). However, that does not appear to be the case.

Applying the principles and holdings of *Gilead*, the Federal Circuit affirmed the District Court’s application of the unclean hands doctrine to bar patent holder Merck from asserting its patent rights against infringer, Gilead. *Gilead*, 888 F.3d at 1248. The District Court had applied the unclean hands doctrine after finding both pre-litigation business misconduct and litigation

FRAND terms. (CBr. at 18; Tr. (Fages) at 1094:17–23.). INVT’s ETSI expert, Mr. Richard Buttrick, one of the founding members of the ETSI IPR Policy Committee, testified that the policy drafters intended for Clause 6.1 to set forth a framework of “good faith” negotiations. (Tr. (Buttrick) at 1049:2-1050:17; *see also* Tr. (Fages) at 1111:9-18 (under French law acting in “good faith” means making “serious proposals, which are consistent with the economic value and the purpose of the contract, and, generally, to adopt an active attitude to achieve successful negotiations”).).

Relying upon the testimony of their own French law expert, Dr. Phillipe Stoffel-Munck, who also agreed that French law governs the ETSI IPR standards, Respondents nonetheless disagreed with Dr. Fages’ interpretation of French law and contended that, under French contract law, an ETSI IPR Declaration is a contract that *obligates* the declarant to be “prepared to grant licenses and to actually grant them . . . under FRAND terms.” (Tr. (Stoffel-Munck) at 2320:9–2324:1, 2327:2–11; *see also* RX-0789.0003; RX-0813.0004). As explained by Respondents’ ETSI expert, Professor Rudi Bekkers, the overall objective of the ETSI IPR Policy is “to ensure that patent licenses are being available for those patents that are required to implement the standards created by ETSI.” (Tr. (Bekkers) at 2224:9–15.).

In 337-TA-800, Judge Shaw also addressed this dispute over how the ETSI IPR requirements should be interpreted under French law. Judge Shaw appeared to rule in INVT’s favor. (*Certain Wireless Devices with 3G Capabilities and Components Thereof*, Inv. No. 337-TA-800, Initial Determination at 427 (July 29, 2013) (“Under French law, the type of obligation set forth in the ETSI undertaking is best described as *un accord de principe* (agreement in principle). . . . This imposes on both negotiating parties a duty to negotiate in good faith. . . . It does not, however, impose an obligation actually to conclude a contract.”) (not reviewed and thus adopted in Commission Opinion (Doc. ID No. 524626)).).

As Staff observed, neither a definitive ruling on Respondents’ Defense of unclean hands, nor its application are required here. (SBr. at 78.). This is because since it is a finding of this initial decision that the Asserted Patents are not standard essential, licensing negotiations that Parties conducted at length, albeit desultorily (from 2015-2018) with respect to the Asserted Patents are not subject to FRAND obligations. That said, a subsequent public interest, remedy and bond filing will provide in-depth analysis of the Parties evidence on the FRAND negotiations in the alternative in case the findings of this decision are overturned to find that the Asserted Patents are standard essential.

Public Version

misconduct that the District Court attributed to Merck. (*Id.* at 1239.). Among the facts the District Court considered were that a Merck employee had gained unauthorized access to information pertaining to the product of a third-party (later acquired by Gilead). The Merck employee arranged for the prosecution of the patent claims directed to the product that Gilead had acquired, and then lied about his actions during deposition and trial testimony in subsequent litigation between Merck and Gilead. (*Id.* at 1240-47.). Importantly, the Federal Circuit affirmed the District Court's finding of a direct connection between Merck's misconduct and its ensuing patent litigation against Gilead. Gilead was found to have infringed Merck's asserted patents. Yet because of Merck's misconduct, the Circuit Court denied Merck its requested remedy.

Ultimately, Respondents' unclean hands Affirmative Defense fails here because it lacks the required connection between the alleged misconduct (INVT's supposed failure to meet its FRAND obligations) and a finding of infringement. As Staff argued in opposition to the application of Respondents' unclean hands Affirmative Defense, because none of the Asserted Patents is essential¹⁰³ they are not subject to FRAND obligations. (SBr. at 78.). This initial decision concurs with Staff's observations and conclusions. Thus, Respondents' unclean hands Affirmative Defense is not applicable.

¹⁰³ Respondents asserted their unclean hands Affirmative Defense in the alternative and only if the Asserted Patents are found to be essential to the 3G or LTE standards on appeal. (RBr. at 88 (arguing unclean hands defense "assuming the Asserted Patents are essential"), 55 ("To the extent the ALJ determines that the asserted patents are actually essential to the 3G and/or LTE standards, INVT is obligated to license any [SEPs] in its portfolio to Respondents on FRAND terms under the ETSI IPR Policy.")).

D. Apple’s Estoppel and Waiver Defenses Are Unavailing¹⁰⁴

Apple argued that, as a matter of equity, the injunctive relief that INVT seeks should be estopped or waived due to the behavior of INVT’s predecessor in interest, Panasonic, and Apple’s reliance on that behavior. (RBr. at 88-89.). Equitable estoppel and waiver bar relief where the patentee’s conduct “leads the alleged infringer to reasonably infer that the patentee does not intend to enforce its patent against the alleged infringer.” *High Point SARL v. Sprint Nextel Corp.*, 817 F.3d 1325, 1330 (Fed. Cir. 2016). The alleged infringer must also rely on that conduct and establish that it will be “materially prejudiced” by the patentee’s claim. *Id.*

Estoppel: Apple claimed that it “relied on Panasonic’s ETSI IPR declarations, which bind INVT, that the Asserted Patents would be available to license on FRAND terms and conditions, and invested billions of dollars to develop the products that INVT now seeks to exclude.” (RBr. at 88-89.). Apple contended that equitable estoppel is appropriate against INVT because, in seeking an exclusion order, INVT has “reneged on Panasonic’s ETSI declarations and Panasonic’s representations to ETSI about when, if at all, injunctive relief would be sought for purportedly essential patents.” (*Id.* at 89 (citing CX-0367C; CX-0369; CX-0454, CX-0455, CX-0456; CX-0459; RX-0188.1–2, 8–9; RX-0017.2; Tr. (Buttrick)¹⁰⁵ at 1079:1–15.)).

As will be discussed in the forthcoming recommendation on public interest, remedy and

¹⁰⁴ It appears from Respondents’ Initial Post-Hearing Brief that Respondents HTC and ZTE did not join Apple in asserting an estoppel Affirmative Defense. (RBr. at 88 (“Apple relied on Panasonic’s ETSI IPR declarations”).).

¹⁰⁵ INVT identified Mr. Richard Buttrick a one of INVT’s experts in intellectual property licensing for telecommunications standards and the field of the European Telecommunications Standards Institute’s (‘ETSI’) IPR policy and the history of its development and adoption. Mr. Buttrick graduated with a degree in Electronic Engineering and Physics at the University of Birmingham in 1979. (*See* CPSt. at 11.).

Public Version

bond, Panasonic, the original owner of the '587 and '590 Patents, declared them essential to the 3G and LTE standards in accordance with the ETSI IPR Policy. (Tr. (Rortveit)¹⁰⁶ at 294:2-297:13; CX-0367C; CX-0369; CX-0454; CX-0455; CX-0459.). Clause 6.1 of the ETSI IPR Policy requires that the patent holder be “prepared to grant irrevocable licenses on fair, reasonable, and non-discriminatory (‘FRAND’) terms and conditions.” (CX-0212-0001-2.).

According to INVT, “there is nothing in the ETSI IPR declaration that prevents injunctive relief.” (CRBr. at 47.). INVT also argued that Apple failed to cite to legal authority that the ETSI IPR declaration prevents injunctive relief where a party relying on the declarations would be “materially prejudiced.” (*Id.* (citing *Certain Audiovisual Components and Products Containing the Same*, Inv. No. 337-TA-837, Initial Determination at 351 (July 18, 2013) (not applying equitable estoppel even when FRAND obligations breached).).

Waiver: Apple argued that Panasonic failed to comply with its obligation to timely disclose the Asserted Patents as essential to the 3G and LTE standards. (RBr. at 89.). Waiver occurs when the patentee’s “conduct was so inconsistent with an intent to enforce its rights as to induce a reasonable belief that such right has been relinquished.” *Core Wireless Licensing S.A.R.L. v. Apple Inc.*, 899 F.3d 1356, 1365 (Fed. Cir. 2018) (citing *Hynix Semiconductor Inc. v. Rambus Inc.*, 645 F.3d 1336, 1348 (Fed. Cir. 2011).). The *Hynix* court made clear that “[s]uch conduct can be shown where (1) the patentee had a duty of disclosure to the standard setting organization, and (2) the patentee breached that duty.” *Id.*

According to Apple, Panasonic did not declare the '590 and '587 patents as essential to

¹⁰⁶ When he testified during the Hearing on September 12, 2019, Jon Rortveit was Inventergy’s Senior Vice President of acquisitions and licensing. (Tr. (Rortveit) at 289:19-23.). Mr. Rortveit was responsible for helping Inventergy acquire the patent portfolio at issue from Panasonic. (*Id.* at 292:3-294:1.).

Public Version

the 3G standard “until December 2005, one and a half years after the standard was adopted, CX-0367C.0008. Similarly, Apple argued that Panasonic did not declare the Asserted Patents to be essential to the LTE standard until March 2010, more than two years after the standard was adopted, CX-0459.10. (RBr. at 89.). Moreover, according to Apple, Panasonic never declared the ’439 patent as essential to any standard. (*Id.*).

According to INVT, while ETSI’s IPR Policy requires members to “inform ETSI about their own . . . Essential IPRs,” the Policy also makes clear that members have “no obligation to conduct IPR searches.” (RRBr. at 47-48 (citing CX-0280-0055; CX-0212-0001, clauses 4.1, 4.2.). INVT’s expert Mr. Buttrick testified that SEPs are declared “before standardization, during standardization, and after standardization,” and that the IPR Policy drafters specifically considered providing a timeframe for declarations, but chose not to. (Tr. (Buttrick) at 1060:11-1061:8 (testifying regarding CX-0771-0005, note 1), 1062:2-7.). INVT also argued that, in addition to submitting “specific declarations” for essentiality of the ’590 Patent to the 3G/UMTS and LTE standards, Panasonic submitted “general declarations” for all of its IPRs, including the ’439 patent. (RRBr. at 48 (citing CX-0454 (LTE, March 16, 2010); CX-0455 (LTE, July 16, 2009); CX-0456 (LTE, Oct. 25, 2010); CX-0369 (LTE-A, Aug. 31, 2011)).).

Notwithstanding INVT’s and Apple’s arguments, Apple’s estoppel and waiver defenses are unavailing. Both relied upon a finding that the Asserted Patents are standard essential. That is not a finding of this initial decision. Additionally, it is evident that it is also finding of this initial decision that the Respondents have not infringed the Asserted Patents.¹⁰⁷ (*Accord*, SBr. at

¹⁰⁷ Apple clearly raised its estoppel and waiver Affirmative Defenses in the alternative and if an Asserted Patent were to found essential to the 3G or LTE standards either in this initial decision and presumably on appeal. (RBr. at 88-89 (“Apple relied on Panasonic’s ETSI IPR declarations, which bind INVT, that the

79.). Apple's estoppel and waiver defenses are not applicable since the required predicates have not been met.

XI. FINDINGS OF FACT AND CONCLUSIONS OF LAW

1. The Jurisdiction and standing requirements are satisfied.
2. No asserted patent claim is essential to the 3G or LTE standard.
3. All asserted claims of the Asserted Patents: that is claim 4 of U.S. Patent No. 7,206,587, claims 3 and 4 of U.S. Patent No. 6,760,590, and claims 1 and 2 of U.S. Patent No. 7,343,439, are valid.
4. All asserted claims of the Asserted Patents: that is claim 4 of U.S. Patent No. 7,206,587, claims 3 and 4 of U.S. Patent No. 6,760,590, and claims 1 and 2 of U.S. Patent No. 7,343,439 are not standard essential to the 3G or LTE standards.
5. None of the asserted claims of the Asserted Patents are satisfied by the Accused Products, all of which practice the 3G or LTE standards.
6. None of the Domestic Industry ("DI") Products practices an asserted claim of any of the Asserted Patents. Therefore, INVT has not satisfied the technical prong of the domestic industry requirement.
7. Because none of the DI Products practices an asserted claim of the Asserted Patents, Samsung's domestic activities with respect to the DI Products do not satisfy the economic prong of the domestic industry requirement under 19 U.S.C. § 337(a)(3)(A), (a)(3)(B) or (a)(3)(C), by operation of law.
8. If finding No. 7 is overturned, and it is determined that the DI Products practice one or more of the asserted claims, Samsung's domestic expenditures on the DI Products would satisfy the economic prong of the domestic industry requirement under 19 U.S.C. § 337(a)(3)(A) and (a)(3)(B).
9. Respondents have not violated Section 337 of the Tariff Act of 1930, as amended, by importing into the United States, selling for importation, or selling within the United States after importation certain LTE- and 3G-compliant cellular communications devices.

Asserted Patents would be available to license on FRAND terms and conditions, and invested billions of dollars to develop the products that INVT now seeks to exclude."), 55 ("To the extent the ALJ determines that the asserted patents are actually essential to the 3G and/or LTE standards, INVT is obligated to license any standard essential patents ("SEPs") in its portfolio to Respondents on FRAND terms under the ETSI IPR Policy.") (emphasis added).).

Public Version

The lack of discussion of any matter raised by the Parties, or any portion of the record, does not indicate that it has not been considered. Rather, any such matter(s) or portion(s) of the record has/have been determined to be irrelevant, immaterial or meritless. Arguments made on briefs, which were otherwise unsupported by record evidence or legal precedent, have been accorded no weight.

XII. CONCLUSION AND ORDER

This Initial Determination on Violation of Section 337 of the Tariff Act of 1930 is certified to the Commission. All orders and documents, filed with the Secretary, including the exhibit lists enumerating the exhibits received into evidence in this Investigation, that are part of the record, as defined in 19 C.F.R. § 210.38(a), are not certified, since they are already in the Commission's possession in accordance with Commission Rules. *See* 19 C.F.R. § 210.38(a). In accordance with 19 C.F.R. § 210.39(c), all material found to be confidential under 19 C.F.R. § 210.5 is to be given *in camera* treatment.

After the Parties have provided proposed redactions of confidential business information ("CBI") that have been evaluated and accepted, the Secretary shall serve a public version of this ID upon all parties of record. The Secretary shall serve a confidential version upon counsel who are signatories to the Protective Order (Order No. 1) issued in this Investigation.

Pursuant to 19 C.F.R. § 210.42(h), this Initial Determination shall become the determination of the Commission unless a party files a petition for review pursuant to 19 C.F.R. § 210.43(a) or the Commission, pursuant to 19 C.F.R. § 210.44, orders on its own motion a review of the Initial Determination or certain issues therein.

Within fourteen (14) days of the date of this document, the Parties shall submit to the Office of Administrative Law Judges a joint statement regarding whether or not they seek to

Public Version

have any portion of this document deleted from the public version. The Parties' submission shall be made by hard copy and must include a copy of this ID with yellow highlighting, with or without red brackets, indicating any portion asserted to contain CBI to be deleted from the public version. The Parties' submission shall also include an index identifying the pages of this document where proposed redactions are located. The Parties' submission concerning the public version of this document need not be filed with the Commission Secretary.

SO ORDERED.



MaryJoan McNamara
Administrative Law Judge

PUBLIC CERTIFICATE OF SERVICE

I, Lisa R. Barton, hereby certify that the attached **INITIAL DETERMINATION** has been served by hand upon the Commission Investigative Attorney, **Reginald Lucas, Esq.**, and to the following parties as indicated, on **March 9, 2020**.



Lisa R. Barton, Secretary
U.S. International Trade Commission
500 E Street, SW, Room 112
Washington, DC 20436

On Behalf of Complainant INVT SPE LLC:

Bryan J. Vogel, Esq.
ROBINS KAPLAN LLP
399 Park Avenue, Suite 3600
New York, NY 10022

- Via Hand Delivery
- Via Express Delivery
- Via First Class Mail
- Other: _____

On Behalf of Respondent Apple Inc.:

Robert A. Appleby, P.C.
KIRKLAND & ELLIS LLP
601 Lexington Avenue
New York, NY 10022

- Via Hand Delivery
- Via Express Delivery
- Via First Class Mail
- Other: _____

On Behalf of Respondents HTC Corporation and HTC America, Inc.:

Stephen S. Korniczky, Esq.
SHEPPARD, MULLIN, RICHTER & HAMPTON LLP
12275 El Camino Real, Suite 200
San Diego, CA 92130

- Via Hand Delivery
- Via Express Delivery
- Via First Class Mail
- Other: _____

On Behalf of Respondents ZTE Corporation and ZTE (USA) Inc.:

Jay H. Reiziss, Esq.
McDERMOTT WILL & EMERY LLP
500 North Capitol Street, NW
Washington, DC 20001

- Via Hand Delivery
- Via Express Delivery
- Via First Class Mail
- Other: _____

UNITED STATES INTERNATIONAL TRADE COMMISSION

Washington, D.C.

In the Matter of

CERTAIN LTE- AND 3G-COMPLIANT
CELLULAR COMMUNICATIONS
DEVICES

Inv. No. 337-TA-1138

**ORDER NO. 40: CONSTRUING TERMS IN DISPUTE AND ADOPTING
AGREED-UPON CONSTRUCTIONS FROM ASSERTED
CLAIMS OF THE PATENTS AT ISSUE (*MARKMAN*
CLAIM CONSTRUCTION)**

(July 15, 2019)

I. INTRODUCTION

This Order resolves the claim construction disputes identified in this Investigation by Complainant INVT SPE LLC (“INVT”), Respondents Apple Inc., HTC Corporation, HTC America, Inc., ZTE Corporation, and ZTE (USA) (“Respondents,” and with INVT, “the Private Parties”), and Commission Investigative Staff (“Staff,” and with the Private Parties, “the Parties”).

On February 1, 2019, INVT filed its Opening *Markman* Brief (“COMBr.”). (Doc. ID No. 665735 (Feb. 1, 2019).). Respondents filed their Opening Claim Construction Brief (“ROMBr.”) the same day. (Doc. ID No. 665740 (Feb. 1, 2019).). Staff filed its Initial *Markman* Brief (“SOMBr.”) on February 28, 2019. (Doc. ID No. 668768 (Feb. 28, 2019).).

INVT filed its Reply *Markman* Brief (“CRMBr.”) on March 12, 2019. (Doc. ID No. 669862 (Mar. 12, 2019).). The same day, Respondents filed their Reply Claim Construction

Brief (“RRMBr.”), (Doc. ID No. 669880 (Mar. 12, 2019)), and Staff filed its Reply *Markman* Brief (“SRMBr.”), (Doc. ID No. 669871 (Mar. 12, 2019)).

A *Markman* hearing was held on April 3, 2019. (Order No. 22 (Mar. 18, 2019)). A transcript of the hearing (“*Markman* Transcript”) was filed the next day. (Doc. ID No. 672229 (Apr. 4, 2019)).

On April 10, 2019, the Parties filed their Joint Final Post-*Markman* Proposed Claim Terms for Construction, with an attached claim construction chart (“Joint CC Chart”). (Doc. ID No. 672723 (Apr. 10, 2019)). That submission set forth seven (7) disputed claim terms that the Parties proposed for court construction and two (2) terms with agreed-upon constructions. (*Id.*, Attach. at 1-7.). This Order provides constructions for each of the seven (7) disputed claim terms and adopts the agreed-upon constructions. The claim terms arise from four asserted patents: (1) U.S. Patent No. 6,760,590 (“590 patent”); (2) U.S. Patent No. 7,206,587 (“587 patent”); (3) U.S. Patent No. 7,848,439 (“439 patent”), and (4) U.S. Patent No. 7,339,949 (“949 patent”) (collectively the “Asserted Patents”).

II. TERMS CONSTRUED IN THIS ORDER

A. Claim Scope

Claim terms are construed in this Order solely for the purposes of this Section 337 Investigation. Only claim terms in controversy need to be construed, and then only to the extent necessary to resolve the controversy. *Vanderlande Indus. Nederland BV v. Int’l Trade Comm.*, 366 F.3d 1311, 1323 (Fed. Cir. 2004); *Vivid Tech., Inc. v. Am. Sci. & Eng’g, Inc.*, 200 F.3d 795, 803 (Fed. Cir. 1999).

B. Applicable Ground Rules

Going forward, the Parties are limited to the constructions adopted in this Order. Modified or new constructions set forth for the first time in pre- or post-hearing briefs will be

waived. Similarly, it will not be appropriate for any party to seek additional claim construction during the Hearing or merely to state that a claim term that may be implicated in an expert report or expert testimony has either a “plain or ordinary” meaning, or that a claim term is “indefinite.” (See Order No. 2 at 8; G.R. 1.14.). If any party proposes a “plain and ordinary meaning or indefiniteness,” its position must be explained and be consistent with this Order.

III. APPLICABLE LAW¹

A. Claim Construction Generally

Claim construction begins with the language of the claims themselves. Claims should be given their ordinary and customary meaning as understood by a person of ordinary skill in the art, viewing the claim terms in the context of the entire patent. *Phillips v. AWH Corp.*, 415 F.3d 1303, 1312-13 (Fed. Cir. 2005). In some cases, the plain and ordinary meaning of claim language is readily apparent and claim construction will involve little more than “the application of the widely-accepted meaning of commonly understood words.” *Id.* at 1314. In other cases, claim terms have a specialized meaning and it is necessary to determine what a person of ordinary skill in the art would have understood disputed claim language to mean by analyzing “the words of the claims themselves, the remainder of the specification, the prosecution history, and extrinsic evidence concerning relevant scientific principles, as well as the meaning of technical terms, and the state of the art.” *Id.* (quoting *Innova/Pure Water, Inc. v. Safari Water Filtration Sys., Inc.*, 381 F.3d 1111, 1116 (Fed. Cir. 2004)).

The claims themselves provide substantial guidance with regard to the meaning of disputed claim language. *Phillips*, 415 F.3d at 1314. “[T]he context in which a term is used in

¹ The constructions of the disputed claim terms generally follow and apply the law as described herein. To the extent possible, the case law that applies to a construction is either identified explicitly, or implicitly in adopting a party’s argument or construction.

the asserted claim can be highly instructive.” *Id.* Similarly, other claims of the patent at issue, regardless of whether they have been asserted against Respondents, may show the scope and meaning of disputed claim language. *Id.*

In cases in which the meaning of a disputed claim term in the context of the patent’s claims is uncertain, the specification is used as the “single best guide to the meaning of a disputed term.” *Id.* at 1321. Moreover, “[t]he construction that stays true to the claim language and most naturally aligns with the patent’s description of the invention will be, in the end, the correct construction.” *Id.* at 1316. As a general rule, however, the particular examples or embodiments discussed in the specification are not to be read into the claims as limitations. *Id.* at 1323.

The prosecution history may also explain the meaning of claim language, although “it often lacks the clarity of the specification and thus is less useful for claim construction purposes.” *Id.* at 1317. The prosecution history consists of the complete record of the patent examination proceedings before the U.S. Patent and Trademark Office, including cited prior art. *Id.* The prosecution history may reveal “how the inventor understood the invention and whether the inventor limited the invention in the course of prosecution, making the claim scope narrower than it would otherwise be.” *Id.*

If the intrinsic evidence is insufficient to establish the clear meaning of a claim, a court may resort to an examination of the extrinsic evidence. *Zodiac Pool Care, Inc. v. Hoffinger Indus., Inc.*, 206 F.3d 1408, 1414 (Fed. Cir. 2000). Extrinsic evidence may shed light on the relevant art, and “consists of all evidence external to the patent and prosecution history, including expert and inventor testimony, dictionaries, and learned treatises.” *Phillips*, 415 F.3d at 1317. In evaluating expert testimony, a court should disregard any expert testimony that is

conclusory or “clearly at odds with the claim construction mandated by the claims themselves, the written description, and the prosecution history, in other words, with the written record of the patent.” *Id.* at 1318. Moreover, expert testimony is only of assistance if, with respect to the disputed claim language, it identifies what the accepted meaning in the field would be to one skilled in the art. *Symantec Corp. v. Comput. Assocs. Int’l, Inc.*, 522 F.3d 1279, 1289 n.3., 1290-91 (Fed. Cir. 2008). Testimony that recites how each expert would construe the term should be accorded little or no weight. *Id.* Extrinsic evidence is inherently “less reliable” than intrinsic evidence, and “is unlikely to result in a reliable interpretation of patent claim scope unless considered in the context of the intrinsic evidence.” *Phillips*, 415 F.3d at 1318-19.

Extrinsic evidence is a last resort: “[i]n those cases where the public record unambiguously describes the scope of the patented invention, reliance on any extrinsic evidence is improper.” *Vitronics Corp. v. Conceptoronic, Inc.*, 90 F.3d 1576, 1583 (Fed. Cir. 1996).

B. Means-Plus-Function Claim Terms

“[T]he failure to use the word ‘means’ . . . creates a rebuttable presumption . . . that § 112, [¶] 6 does not apply.” *Williamson v. Citrix Online LLC*, 792 F.3d 1339, 1348 (Fed. Cir. 2015). However, “[i]n making the assessment of whether the limitation in question is a means-plus-function term subject to the strictures of § 112, para. 6, . . . the essential inquiry is not merely the presence or absence of the word ‘means’ but whether the words of the claim are understood by persons of ordinary skill in the art to have a sufficiently definite meaning as the name for structure.” *Id.* at 1348. “Generic terms such as ‘mechanism,’ ‘element,’ ‘device,’ and other nonce words that reflect nothing more than verbal constructs may be used in a claim in a manner that is tantamount to using the word ‘means’ because they ‘typically do not connote sufficiently definite structure’ and therefore may invoke § 112, para. 6.” *Id.* at 1350. However, claims directed at generic functions like “processing,” “receiving,” and “storing” can be achieved by

any general purpose computer without special programming and thus do not necessarily require construction under Section 112 ¶ 6. *In re Katz Interactive Call Processing Patent Litig.*, 639 F.3d 1303, 1316 (Fed. Cir. 2011) (contrasting cases involving “specific functions that would need to be implemented by programming a general purpose computer to convert it into a special purpose computer capable of performing those specified functions”).

Some patent claim limitations are explicitly drafted in means-plus-function format, and they are usually governed by 35 U.S.C. § 112 ¶ 6.

An element in a claim for a combination may be expressed as a means or step for performing a specified function without the recital of structure, material, or acts in support thereof, and such claim shall be construed to cover the corresponding structure, material, or acts described in the specification and equivalents thereof.

35 U.S.C. § 112 ¶ 6. According to the Federal Circuit, “[t]he first step in construing a means-plus-function limitation is to identify the function explicitly recited in the claim.” *Asyst Techs., Inc. v. Empak, Inc.*, 268 F.3d 1364, 1369-70 (Fed. Cir. 2001). The function may only include the limitations contained in the claim language: it is improper to narrow or broaden “the scope of the function beyond the claim language.” *Cardiac Pacemakers, Inc. v. St. Jude Med., Inc.*, 296 F.3d 1106, 1113 (Fed. Cir. 2002).

The next step in the analysis of a means-plus-function claim limitation “is to identify the corresponding structure set forth in the written description that performs the particular function set forth in the claim.” *Asyst*, 268 F.3d at 1369-70. Corresponding structure “must not only perform the claimed function, but the specification must clearly associate the structure with performance of the function.” *Cardiac Pacemakers*, 296 F.3d at 1113.

Section 112 paragraph 6 does not ‘permit incorporation of structure from the written description beyond that necessary to perform the claimed function.’ Structural features that do not actually perform the recited function do not constitute corresponding structure and thus do not serve as claim limitations.

Asyst, 268 F.3d at 1369-70 (citations omitted). For example, features that enable the pertinent

structure to operate as intended are not the same as corresponding structures that actually perform the stated function. *Id.* at 1371. Different embodiments disclosed in the specification may disclose different corresponding structure. *Cardiac Pacemakers*, 296 F.3d at 1113.

A means-plus-function analysis is “undertaken from the perspective of a person of ordinary skill in the art.” *Id.* While the focal point for determining the corresponding structure is the patent specification, other intrinsic evidence remains relevant. The other claims in a patent “may provide guidance and context for interpreting a disputed means-plus-function limitation, especially if they recite additional functions.” *Wenger Mfg., Inc. v. Coating Mach. Sys., Inc.*, 239 F.3d 1225, 1233-34 (Fed. Cir. 2001). If another claim in the patent recites a separate and distinct function, “the doctrine of claim differentiation indicates that these claims are presumptively different in scope.” *Id.* The prosecution history of the patent may also be useful in interpreting a claim written in means-plus-function form. *Cybor Corp. v. FAS Techs., Inc.*, 138 F.3d 1448, 1457 (Fed. Cir. 1998) (abrogated with respect to de novo claim construction). “[P]ositions taken before the PTO may bar an inconsistent position on claim construction under § 112 ¶6” if a “competitor would reasonably believe that the applicant had surrendered the relevant subject matter” as a result of “clear assertions made in support of patentability.” *Id.*

C. Indefiniteness

A patent specification must “conclude with one or more claims particularly pointing out and distinctly claiming the subject matter which the inventor or a joint inventor regards as the invention.” 35 U.S.C. § 112, ¶ 2. Previously, the Federal Circuit held that a patent claim is not indefinite “so long as the claim is amenable to construction, and the claim, as construed, is not insolubly ambiguous.” *Nautilus, Inc. v. Biosig Instruments, Inc.*, 134 S.Ct. 2120, 2124 (2014). More recently, the U.S. Supreme Court determined that this standard lacks precision. *Id.* at 2130. Instead, the Supreme Court held:

we read § 112, ¶ 2 to require that a patent's claims, viewed in light of the specification and prosecution history, inform those skilled in the art about the scope of the invention with reasonable certainty. The definiteness requirement, so understood, mandates clarity, while recognizing that absolute precision is unattainable. The standard we adopt accords with opinions of this Court stating that "the certainty which the law requires in patents is not greater than is reasonable, having regard to their subject-matter."

Id. at 2129 (citations omitted).

A party seeking to invalidate a patent claim must do so by clear and convincing evidence. *See, e.g., Tech. Licensing Corp. v. Videotek, Inc.*, 545 F.3d 1316, 1327 (Fed. Cir. 2008) (citing *Hybritech Inc. v. Monoclonal Antibodies, Inc.*, 802 F.2d 1367, 1375 (Fed. Cir. 1986)).

IV. PERSON OF ORDINARY SKILL IN THE ART

INVT proposed a definition for a person of ordinary skill in the art. As shown below in Figure 1, during the *Markman* hearing, Staff agreed with the definition. Respondents did not offer a definition at the *Markman* hearing or in their claim construction briefs.

Figure 1: Staff Addressing Definition for Person of Ordinary Skill in the Art

11 MR. LUCAS: We only have one definition in this
12 investigation, Your Honor, of what a person of ordinary
13 skill in the art would have been at the time of the patent.
14 That was provided by Complainant's expert, and we have
15 adopted that definition, Your Honor, because there is no
16 other definition. There is no other opinion provided.
17 This opinion came from Complainant's expert
18 witness, one of their expert witnesses in this
19 investigation. But the thing to keep in mind, Your Honor,

(*Markman* Tr. at 29.).

A person of ordinary skill in the art is a hypothetical person of ordinary skill and “ordinary creativity.” *KSB Int’l Co. v. Teleflex, Inc.*, 550 U.S. 398, 420 (2007). “Factors that may be considered in determining [the] level of ordinary skill in the art include: (1) the educational level of the inventor[s]; (2) type of problems encountered in the art; (3) prior art solutions to the problems; (4) rapidity with which inventions are made; (5) sophistication of the technology; and (6) educational level of active workers in the field.” *Envtl. Designs Ltd. v. Union Oil Co. of California*, 713 F.2d 693, 696-97 (Fed. Cir.) (citations omitted). “These factors are not exhaustive but merely a guide to determining the level of ordinary skill in the art.” *Daiichi Sankyo Co. v. Apotex, Inc.*, 501 F.3d 1254, 1256 (Fed. Cir. 2007). The hypothetical person of skill is also separately presumed to have knowledge of all the relevant prior art in the field. *Custom Accessories, Inc. v. Jeffrey-Allan Indus., Inc.*, 807 F.2d 693, 697 (Fed. Cir. 1983).

INVT and Staff’s definition of a person of ordinary skill is as follows:

a person skilled in the art would at least have both a bachelor’s degree in Electrical Engineering or an equivalent field and three years of experience in wireless communications or an MSc degree in Electrical Engineering or an equivalent field and one year of experience in wireless communications.

(COMBr. at 8; SOMBr. at 6-7.). Finding no opposition from Respondents, this Order adopts INVT and Staff’s definition of a person of ordinary skill in the art for the claim construction analysis that follows and going forward as the Investigation proceeds through discovery and into the evidentiary Hearing.

V. ADOPTED CONSTRUCTIONS

As an initial matter, the Parties appear to disagree with respect to the scope of the disputed terms under construction. For example, in the context of claims 3 and 4 of the ’590 patent, Respondents seek to construe “a measurer that . . .,” whereas INVT and Staff focus on an

extended version of that term: “a measurer that measures a downlink channel quality and outputs information that is generated in association with said downlink channel quality.”

In assessing Respondents’ argument that 35 U.S.C. § 112 ¶ 6 applies to every disputed claim term, “the essential inquiry is ... whether *the words of the claim* are understood by persons of ordinary skill in the art to have a sufficiently definite meaning as the name for structure.” *Williamson*, 792 F.3d at 1348 (emphasis added). The § 112 ¶ 6 inquiry must examine the disputed terms in the context of their corresponding claims and also the specification, and resist the evaluation of structural attributes of terms in isolation. *See Apex Inc. v. Raritan Comput., Inc.*, 325 F.3d 1364, 1374 (Fed. Cir. 2003) (“[t]he district court therefore erred in its interpretation of all the limitations as means-plus-function limitations by failing to consider the limitations as a whole”). As compared to Respondents’ identification of abbreviated terms for construction, INVT and Staff’s identification of “full terms” is more in line with how this Order conceptualizes and undertakes the claim construction process.

Additionally, notwithstanding the variety of disputed terms for construction, each Party has advanced nearly identical claim construction positions across all such terms. For example, according to INVT, the disputed limitations are not subject to § 112 ¶ 6 because they do not use the word “means,” are sufficiently associated with structure in their corresponding claims and specifications, and in general provide sufficient detail to suggest structure to persons of ordinary skill in the art. (COMBr. at 18.). Staff agrees. (SOMBr. at 31.).

INVT and Staff also import certain hardware and/or software to provide structure for the functions recited by the disputed claim terms. For the construction of every disputed term, INVT proposes “a digital signal processor (DSP) with code implemented, an application specific integrated circuit (ASIC), discrete circuitry and memory, and/or combinations thereof that”

performs the recited function. (Joint CC Chart at 1-7.). Likewise, for every disputed term, Staff proposes “a signal processor executing code operating in accordance with the claim language, circuitry operating in accordance with the claim language, or a combination thereof.” (*Id.*).

Respondents were nearly as consistent in terms of proposed constructions of disputed terms. They argued that each term was described solely in functional terms, that nothing in the claim indicated any particular structure for the term, and that the term did not connote any such structure to one of ordinary skill in the art. (ROMBr. at 1-2; RRMBR. at 1-2.). Respondents also asserted that descriptions of the disputed terms were noticeably absent from the specifications and file histories and that the terms amounted to abstractions of hardware or software that performed the claimed function. (*Id.*). Consequently, according to Respondents, § 112 ¶ 6 applied to all of the disputed terms, making each term a “means for” performing the recited function. (Joint CC Chart at 1-7.). Respondents also argued that each term was indefinite for failing to disclose corresponding structure in the relevant specification. (*Id.*). For certain terms, in the alternative, Respondents proposed corresponding structure found in the specification. (*Id.*).

These arguments are addressed, on a term-by-term basis, below.

A. '590 and '587 patents

1. Background

The '590 and '587 patents share the same specification because the '587 patent issued from a continuation of the application that issued as the '590 patent. (JXM-0002 ('587 Patent) at 1.). The shared specification of '590 and '587 patents recognizes that, “[i]n a cellular communication system, one base station performs radio communication with a plurality of communication terminals simultaneously.” (*Id.* at 1:15-17.). Initially, “the base station transmits

a pilot signal to each communication terminal. Each communication terminal estimates the downlink channel quality using a CIR (desired carrier to interference ratio) based on the pilot signal, etc., and finds a transmission rate at which communication is possible.” (*Id.* at 1:30-35.). “[B]ased on the transmission rate at which communication is possible, each communication terminal selects a communication mode, which is a combination of packet length, coding method, and modulation method, and transmits a data rate control (hereinafter referred to as ‘DRC’) signal indicating the communication mode to the base station.” (*Id.* at 1:35-41.).

The DRC signal is important because, as shown below in Figure 2, “[g]enerally, taking improvement of system transmission efficiency into consideration, communication resources are allocated with priority to the communication terminal that has the best downlink channel quality—that is to say, the communication terminal that transmits the highest-numbered DRC signal.” (*Id.* at 1:62-67.). Also, “if the communication mode determined by a communication terminal is received erroneously by the base station, there will be an interval during which time-divided communication resources are not used, and downlink throughput falls.” (*Id.* at 2:29-33.). “[T]he communication terminal cannot demodulate or decode the data.” (*Id.* at 2:21-22.).

Figure 2: Figure 1 of the '590 and '587 Patents

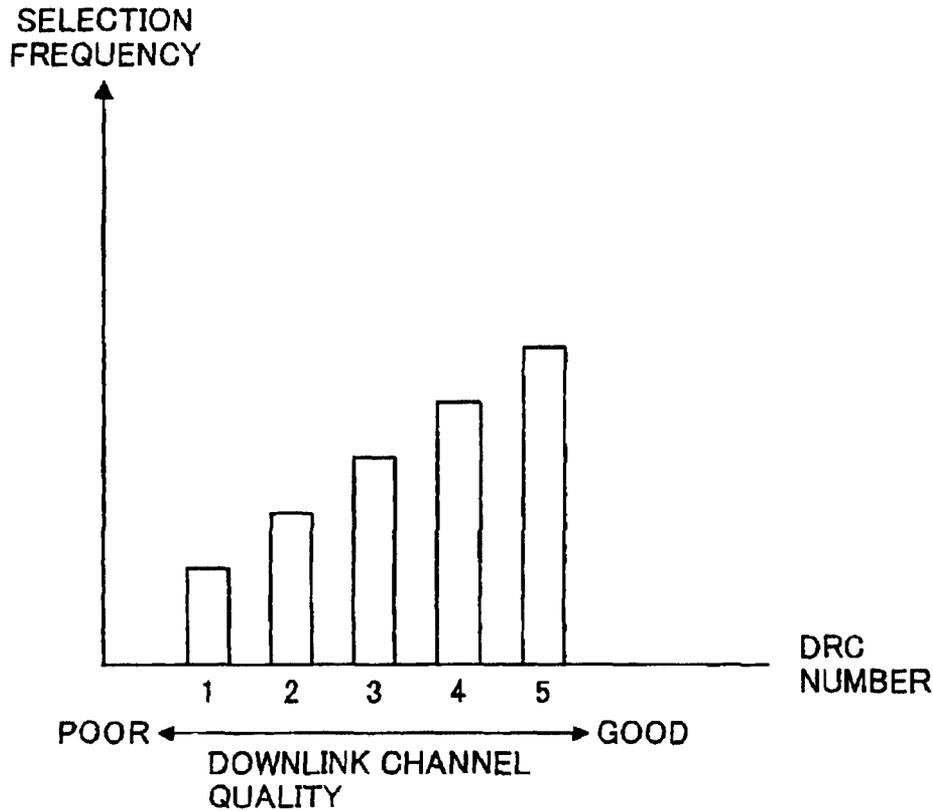

(*Id.* at Fig. 1.).

To guard against this circumstance, the '590 and '587 patents disclose encoding the channel quality information to reduce the likelihood of a base station receiving erroneous channel quality information from a communication terminal. (*Id.* at 2:44-52; 20:4-9.). For example, the '590 and '587 patents recognize that, in terms of error protection, some bits are more important than others in a channel quality reading. (*Id.* at 19:39-54.). “If a CIR value is indicated by a value with a decimal fraction (such as 8.7 dB) ... the amount of change per unit of the integer [bit] is 1 dB, while the amount of change per unit of the fractional [bit] is 0.1 dB[.]” (*Id.* at 19:42-46.). This means that, “if an integer part is received erroneously by a base station, the degree of error is large compared with the case where a fractional part is received

erroneously[.]” (*Id.* at 19:49-51.). In other words, in terms of error protection, the integer bit is more “significant” than the fractional bit.

The ’590 and ’587 patents disclose various embodiments that purportedly reduce the likelihood of a base station receiving erroneous channel quality information. For example, in one embodiment for a CIR value of 8.7 dB, “[t]he 6-bit coding section 1203 converts the value output from the upper digit information generation section 1201 (here, ‘8’) to a 6-bit code word,” while the “4-bit coding section 1204 converts the value output from the lower digit information generation-section 1202 (here, ‘7’) to a 4-bit code word,” “assum[ing] that the number of bits that can be used to indicate a CIR value is ten.” (*Id.* at 2:35-50.). In other words, the integer gets encoded with more precision.

2. Disputed Claim Term Constructions

a. the “measuring” limitations: “a measurer that ...” and “a measuring device that ...”

Claim(s) Term	Complainants' Proposed Construction	Respondents' Proposed Construction	Staff's Proposed Construction	Adopted Construction
<p>Respondents' Proposed Term for Construction: “a measurer that ...”</p> <p>Full Term For Construction: “a measurer that measures a downlink channel quality and outputs information that is generated in association with said downlink channel quality and outputs information that is generated in association”</p>	<p>The full term for construction is: “a measurer that measures a downlink channel quality and outputs information that is generated in association with said downlink channel quality”</p> <p>This term is not subject to 35 U.S.C. § 112 ¶ 6, Plain and ordinary meaning: a digital</p>	<p>Means-plus-function under § 112, ¶ 6</p> <p>Function: “measuring a downlink channel quality and outputting information that is generated in association with said downlink channel quality and composed of a plurality of digits including an upper digit</p>	<p>“a signal processor executing code operating in accordance with the claim language, circuitry operating in accordance with the claim language, or a combination thereof”</p>	<p>“hardware and/or software that measures a downlink channel quality and outputs information that is generated in association with said downlink channel quality”</p>

Claim(s) Term	Complainants' Proposed Construction	Respondents' Proposed Construction	Staff's Proposed Construction	Adopted Construction
with said downlink channel quality” (’590 patent, claim 3, 4)	signal processor (DSP) with code implemented, an application specific integrated circuit (ASIC), discrete circuitry and memory, and/or combinations thereof that measures a downlink channel quality and outputs information that is generated in association with said downlink channel quality	and an lower digit” Structure: <i>Indefinite</i> , or, in the alternative, element 219 of Fig. 3, element 219 of Fig. 6, element 219 of Fig. 9, element 219 of Fig. 11, as discussed in 6:30-33, 6:55-59		

Claim(s) Term	Complainants' Proposed Construction	Respondents' Proposed Construction	Staff's Proposed Construction	Adopted Construction
Respondents' Proposed Term for Construction: “a measuring device that ...” Full Term For Construction: “a measuring device that measures reception quality of a pilot signal to output	The full term for construction is: “a measuring device that measures reception quality of a pilot signal to output information having a plurality of bits that indicate the measured reception quality” This term is not subject to 35 U.S.C. § 112 ¶ 6, Plain and ordinary	Means-plus-function under § 112, ¶ 6 Function: “measuring reception quality of a pilot signal to output information having a plurality of bits that indicate the measured reception quality” Structure:	“a signal processor executing code operating in accordance with the claim language, circuitry operating in accordance with the claim language, or a combination thereof”	“hardware and/or software that measures reception quality of a pilot signal to output information having a plurality of bits that indicate the measured reception quality”

Claim(s) Term	Complainants' Proposed Construction	Respondents' Proposed Construction	Staff's Proposed Construction	Adopted Construction
information having a plurality of bits that indicate the measured reception quality” (’587 patent, claim 4)	meaning: digital signal processor (DSP) with code implemented, an application specific integrated circuit (ASIC), discrete circuitry and memory, and/or combinations thereof that measures reception quality of a pilot signal to output information having a plurality of bits that indicate the measured reception quality	<i>Indefinite</i> , or, in the alternative, element 219 of Fig. 3, element 219 of Fig. 6, element 219 of Fig. 9, element 219 of Fig. 11, as discussed in 6:35-38, 6:59-63		

The “measuring” limitations do not use the word “means.” Thus, it is presumed that § 112 ¶ 6 does not apply. *Williamson*, 792 F.3d at 1349. Respondents bear the burden of overcoming that presumption. *Id.* As set forth below, Respondents failed to carry that burden and show that the “measuring” limitations do not “‘recite[] sufficiently definite structure’ or else recite[] ‘function without reciting sufficient structure for performing that function.’” (*Id.* at 1348.).

The “measuring” limitations perform similar functions. Claims 3 and 4 of the ’590 patent require a “a measurer that measures a downlink channel quality and outputs information that is generated in association with said downlink channel quality.” (JXM-0001 (’590 patent), cls. 3, 4.). Claim 4 of the ’587 patent requires “a measuring device that measures reception quality of a pilot signal to output information having a plurality of bits that indicate the measured reception

quality.” (JXM-0002 (‘587 Patent), cl. 4.). In either term, the function pertains to the measurement of the quality of a connection between a base station and a communication terminal and the output of information that relates to that measurement. Both terms as they appear in the confines of their respective claims are largely devoid of structure, other than the “measuring device” term’s requirement that the “output information” have “a plurality of bits.”

The shared specification of the ’587 and ’590 patents provides additional structural context for the “measuring” limitations. In describing Embodiment 1, the specification notes that the carrier to interference ratio (“CIR”) “measurement section 219 measures the CIR of the pilot signal output from despreading Section 218, and outputs the result to the communication mode determination Section 201,” as shown below in Figure 3. (JXM-0001 (‘590 patent) at 6:32-34; *see also* 6:55-61 (“Next, in the CIR measurement section 219, the CIR of the pilot signal output from despreading section 218 is measured, and based on the CIR, the communication mode is determined by the communication mode determination section 201. Then a DRC signal with a number corresponding to the communication mode is created by the DRC signal creation section 202.”); 16:29-34 (“First, in the communication terminal shown in FIG. 11, the CIR of the pilot signal output from despreading section 218 is measured by the CIR measurement section 219, and a CIR signal is created by the CIR information creation section 801.”); 18:62-65 (“In the code word selector 1001, a CIR signal output from the CIR information creation section 801 is converted to a code word set in the code word table 1002 ...”).).

Figure 3: Figure 3 of the '587 and '590 Patents Showing Components of a Communications Terminal, Including CIR Measurement Section 219

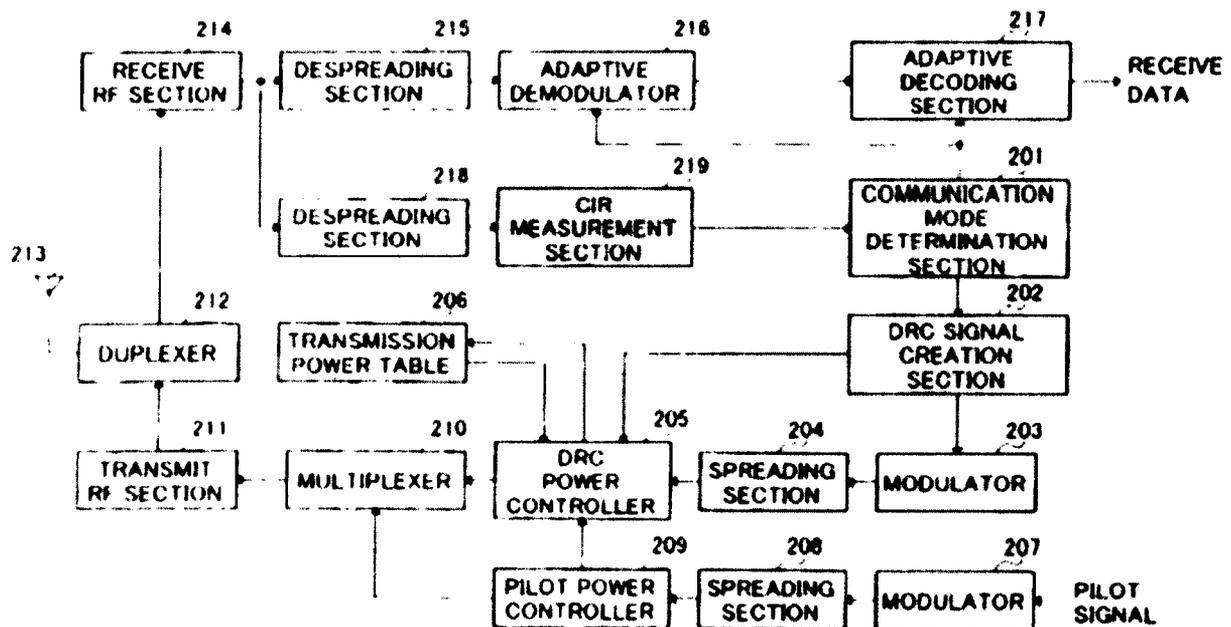

(*Id.*, Fig. 3 (as annotated with highlighting in Respondents’ brief).).

However, it appears that, without more, these passages do not demonstrate that the “measuring” limitations would connote structure to one of ordinary skill in the art. Instead, the passages merely replace the “measuring” limitations with an element identified as “measurement section 219.” Exactly how “measurement section 219” performs the measuring and outputting functions is left unsaid. While the specification discloses that “despreading section 218” and “communication mode determination Section 201” interact with “measurement section 219,” these external structural details merely explain how “measurement section 219” integrates as a component of certain embodiments of the “invention.” These external, connective details do not provide structural details with respect to the internal operation of “measurement section 219.”

However, in its discussion of the prior art, the specification appears to suggest why the “measuring” limitations might lack explicitly disclosed structures and yet still be “understood by

persons of ordinary skill in the art to have a sufficiently definite meaning as the name for structure.” *Williamson*, 792 F.3d at 1348. In the context of prior art High Data Rate (HDR) technology, the specification explains that “[e]ach communication terminal estimates the downlink channel quality using a CIR (desired carrier to interference ratio) based on the pilot signal, etc., and finds a transmission rate at which communication is possible.” (JXM-0002 (‘587 Patent) at 1:32-35.). Additionally, “[d]ata transmission efficiency has *conventionally* been increased for the overall system by setting a transmission rate for each communication terminal according to channel quality by means of HDR.” (*Id.* at 2:7-10.). This is structure, albeit prior art structure, that illuminates at least some of what the “measuring” limitations cover.

In other words, the specification makes clear what the “invention” is and is not, and naturally devotes far more attention to the former. The “invention” pertains to ways of conveying channel quality information to reduce the likelihood of a base station receiving erroneous channel quality information from a communication terminal. The “invention” treats as given the underlining prior art structure for base stations to measure channel quality. That is the primary reason why INVT is correct that, “[w]hen correctly considered in the context of the claims, ... it is abundantly clear that ‘measurer’ and ‘measuring device’ connote structure to a person of ordinary skill.” (CRMBR. at 3.).

In light of the above, Respondents’ position appears to distill to a critique that the specification should have included more information about known, referenced, structure-providing channel quality measurement techniques. If Respondents were to prevail, such that the “measuring” limitations receive § 112 ¶ 6 treatment, it would greatly expand the scope of “purely functional claiming” and effectively write out the interpretive role of a person of ordinary skill in the art, who is presumed to know the prior art. *AllVoice Computing PLC v. Nuance Commc 'ns*,

Inc., 504 F.3d 1236, 1245 (Fed. Cir. 2007) (“In software cases, therefore, algorithms in the specification need only disclose adequate defining structure to render the bounds of the claim understandable to one of ordinary skill in the art.”); *Med. Instrumentation & Diagnostics Corp. v. Elekta AB*, 344 F.3d 1205, 1214 (Fed. Cir. 2003) (“[H]ere there would be no need for a disclosure of the specific program code if software were linked to the converting function and one skilled in the art would know the kind of program to use.”); *Intel Corp. v. VIA Techs., Inc.*, 319 F.3d 1357, 1366 (Fed. Cir. 2003) (holding that the internal circuitry of an electronic device need not be disclosed in the specification if one of ordinary skill in the art would understand how to build and modify the device).

What remains is construction of the “measuring” terms. None of the parties has offered a construction that hews to the intrinsic evidence. The specification does not mention the “digital signal processor (DSP) with code” or the “application specific integrated circuit (ASIC)” that appears in INVT’s proposed construction or the “signal processor executing code” that appears in Staff’s proposed construction. Respondents did not provide a construction other than the application of § 112, ¶ 6.

The proper construction is “hardware and/or software” that performs the recited function. This construction acknowledges that the claimed measurement functionality exists on a “communication terminal” composed of hardware and/or software. This construction also aligns with the treatment of the “measuring” terms by INVT, Respondents, and Staff. INVT notes that “[o]ther courts have construed similar disputed claim limitations by using the phrase ‘hardware and/or software’ that does X, Y, and/or Z.” (COMBr. at 15 n.5 (citing *Evolved Wireless, LLC v. Apple, Inc.*, No. 15-cv-542, 2016 U.S. Dist. LEXIS 156884, *9-10 (D. Del. Nov. 14, 2016) (construing “a transmitting unit for transmitting the circular shifted code sequence having the

second length” as “Hardware and/or software in the apparatus that is capable of transmitting the circular shifted code sequence having the second length.”)). Addressing the “measuring” limitations in *Inter Partes* Review of the ’590 and ’587 patents, Respondent Apple Inc.’s expert Dr. Andrew C. Singer stated that “[a] POSITA would have understood that this channel determination would necessarily be measured by a measurer, which would be software and/or hardware in the subscriber device.” (CXM-0008 (Singer ’590 Decl.) at ¶ 31-32.). Finally, Staff’s proposed construction references a processor executing code, circuitry, “or a combination thereof.”

b. the “coding” limitations: “a coder that ...” and “a coding device that ...”

Claim(s) Term	Complainants' Proposed Construction	Respondents' Proposed Construction	Staff's Proposed Construction	Adopted Construction
<p>Respondents' Proposed Term For Construction: “a coder that ...”</p> <p>Full Term For Construction: “a coder that encodes the information such that the upper digit is assigned a larger number of bits than the lower digit” (’590 patent, claims 3, 4)</p>	<p>The full term for construction is: “a coder that encodes the information such that the upper digit is assigned a larger code number of bits than the lower digit;”</p> <p>This term is not subject to 35 U.S.C. § 112 ¶ 6, Plain and ordinary meaning: a digital signal processor (DSP) with code implemented, an application specific integrated circuit (ASIC), discrete</p>	<p>Means-plus-function under § 112, ¶ 6</p> <p>Function: “encoding the information such that the upper digit is assigned a larger number of bits than the lower digit”</p> <p>Structure: <i>Indefinite</i> or, in the alternative, element 1101 of Fig. 15, as discussed in 20:28-21:10</p>	<p>“a signal processor executing code operating in accordance with the claim language, circuitry operating in accordance with the claim language, or a combination thereof”</p>	<p>“hardware and/or software that encodes the information such that the upper digit is assigned a larger number of bits than the lower digit”</p>

Claim(s) Term	Complainants' Proposed Construction	Respondents' Proposed Construction	Staff's Proposed Construction	Adopted Construction
	circuitry and memory, and/or combinations thereof that encodes the information such that the upper digit is assigned a larger number of bits than the lower digit;			

Claim(s) Term	Complainants' Proposed Construction	Respondents' Proposed Construction	Staff's Proposed Construction	Adopted Construction
<p>Respondents' Proposed Term For Construction: "a coding device that..."</p> <p>Full Term For Construction: "a coding device that encodes the information to obtain a code word" such that "the most significant bit of the plurality of bits is less susceptible to errors in a propagation path than other bits of the plurality of bits" ('587 patent,</p>	<p>The full term for construction is:</p> <p>"a coding device that encodes the information to obtain a code word"</p> <p>This term is not subject to 35 U.S.C. § 112 ¶ 6, Plain and ordinary meaning: a digital signal processor (DSP) with code implemented, an application specific integrated circuit (ASIC), discrete circuitry and memory, and/or combinations thereof that encodes the information to</p>	<p>Means-plus-function under § 112, ¶ 6</p> <p>Function: "encoding the information to obtain a code word"</p> <p>Structure: <i>Indefinite</i> or, in the alternative, element 1101 of Fig. 15, as discussed in 20:28-21:10</p>	<p>"a signal processor executing code operating in accordance with the claim language, circuitry operating in accordance with the claim language, or a combination thereof"</p>	<p>§ 112, ¶ 6 applies</p> <p>Function: "encod[ing] the information to obtain a code word such that the most significant bit of the plurality of bits is less susceptible to errors in a propagation path than other bits of the plurality of bits"</p> <p>Structure: element 1101 of Fig. 15, as</p>

claim 4)	obtain a code word.			discussed in 20:28-21:10, and equivalents thereof
----------	---------------------	--	--	---

The “coding” limitations do not use the word “means.” Thus, it is presumed that § 112 ¶ 6 does not apply. *Williamson*, 792 F.3d at 1349. Respondents bear the burden of overcoming that presumption. *Id.* As set forth below, with respect to the “a coder ...” limitation, Respondents have failed to carry that burden and show that the limitation does not “‘recite[] sufficiently definite structure’ or else recite[] ‘function without reciting sufficient structure for performing that function.’” (*Id.* at 1348.). However, with respect to the “a coding device ...” limitation, Respondents carried the burden and § 112 ¶ 6 applies.

The “coding limitations” perform similar functions. Claims 3 and 4 of the ’590 patent require “a coder that encodes the information such that the upper digit is assigned a larger number of bits than the lower digit.” (JXM-0001 (’590 patent), cls. 3, 4.). Claim 4 of the ’587 patent requires “a coding device that encodes the information to obtain a code word.” (JXM-0002 (’587 Patent), cl. 4.). Claim 4 of the ’587 patent also requires that “the coding device encodes the information such that the most significant bit of the plurality of bits is less susceptible to errors in a propagation path than other bits of the plurality of bits.” (*Id.*). In either of the “coding limitations,” the function pertains to the coding of information.

Neither limitation is found *verbatim* in the specification. However, within the confines of their respective claims, the “coding limitations” have distinct structural footprints. In contrast to the “coding device” limitation, the “coder” limitation appears to provide clear algorithmic structure insofar as it offers some explanation for how the coder operates to encode information: “the upper digit is assigned a larger number of bits than the lower digit” in the encode

information. The “coding device” limitation, by contrast, merely requires encoding “the information to obtain a code word” “such that the most significant bit of the plurality of bits is less susceptible to errors in a propagation path than other bits of the plurality of bits.” In other words, the “coding device” limitation says very little about how the encoding will take place other than to draw a circle around an amorphous category of encoding techniques where the “the most significant bit ... is less susceptible to errors.”

The shared specification of the '587 and '590 patents provides interpretive, structural context for the “coding limitations.” For example, seemingly referring to solutions known in the art at the time of the “invention,” the specification explains: “CIR information is normally converted to a code word with a limited number of bits before being transmitted to a base station, and there are also limits on the transmission power and spreading code spreading factor that can be used in transmitting CIR information. There are thus limits to making CIR information overall insusceptible to errors, and it is difficult to do so.” (JXM-0002 ('587 Patent) at 19:55-60.). This statement reveals that encoding CIR information with a limited number of bits was already known in the art and acknowledges the difficulty of reducing errors with a limited number of bits.

Turning to the disclosed “invention” that supposedly overcame this difficulty, the specification describes an embodiment in which channel quality information is comprised of an “upper” and “lower digit,” where the “upper digit” of the channel quality information is encoded by a “6-bit coding section” (element 1203), and the lower digit is encoded by a “4-bit coding section” (element 1201). (*Id.* at 20:29-41.). This embodiment sounds much like what the “coder” limitation requires because “the upper digit is assigned a larger number of bits than the lower digit.” (JXM-0001 ('590 patent), cls. 3-4.). Given the specificity with which the “coder”

limitation claims its encoding technique, with clear support in the specification, it is apparent that this limitation would be “understood by persons of ordinary skill in the art to have a sufficiently definite meaning as the name for structure.” *Williamson*, 792 F.3d at 1348.

However, the “coding device” limitation lacks specificity in terms of structure. To interpret this limitation, INVT points to an embodiment in the specification in which element 1101 “converts a CIR value to a code word and creates a CIR signal, and outputs the created CIR signal to a multiplexer 210.” (COMBr. at 24 (citing JXM-0001 (‘590 patent) at 20:20-26).). However, this appears to be a restatement of what was known in the art, not a disclosure that provides structural specificity for a defining feature of the “invention.” What is missing with respect to the “coding device” limitation is structural mooring with respect to how the encoding takes place “such that the most significant bit of the plurality of bits is less susceptible to errors in a propagation path than other bits of the plurality of bits.” The term “most significant bit” does not appear in the specification. The term “less susceptible to errors in a propagation path” is open-ended and relative, not tied to structure. In other words, the “coding device” language of claim 4 of the ‘587 patent is simply another way of covering means for the following function: “encoding the information to obtain a code word” such that “the most significant bit of the plurality of bits is less susceptible to errors in a propagation path than other bits of the plurality of bits.”

Thus, § 112 ¶ 6 applies and the “coding device” limitation covers only corresponding embodiments disclosed in the specification. However, Respondents have not proven by clear and convincing evidence that the “coding device” limitation is indefinite. Instead, the “coding device” limitation is limited to element 1101 of Fig. 15, as discussed in column 20, line 28 to column 21, line 10, in the context of disclosed Embodiment 6, and equivalents thereof. This

finding reflects Respondents' alternate construction of the "coding device" term. By way of example, Figure 4 below displays Figure 15 of the '587 patent, "a block diagram showing the configuration of the CIR signal creation section of a communication terminal according to Embodiment 6 of the present invention[.]" (JXM-0002 ('587 Patent) at 2:62-64.).

Figure 4: Figure 15 of the '587 and '590 Patents Depicting Embodiment 6

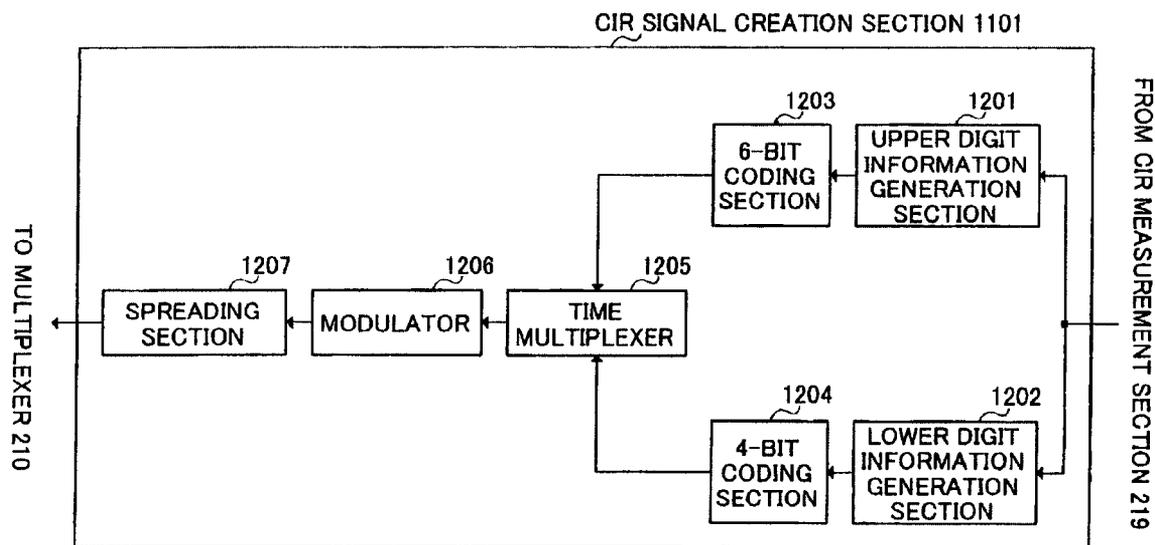

(*Id.* at Fig. 15.).

3. Agreed-Upon Constructions

In their Joint CC Chart, the Parties did not present an agreed-upon construction of a claim term in the '590 patent or '587 patent.

B. '439 patent

1. Background

The '439 patent relates to an orthogonal frequency division multiplexing (OFDM) system. (JXM-0005 ('439 Patent) at 1:12-14.). The '439 patent describes such a system adapting to changing channel conditions by modifying the modulation and coding parameters based on the estimated channel quality, a technique known as adaptive modulation and coding

(AMC). (*Id.* at 1:34-40.). To reduce interference, “OFDM systems transmit high-speed data using a large number of subcarriers that are orthogonal[.]” (*Id.* at 1:19-21.). As shown below in Figure 5, in conventional OFDM systems, “all of the subcarriers on the OFDM frequency domain are divided into several subbands,” totaling N in number. (*Id.* at 2:19-21.).

Figure 5: Figure 2 of the '439 Patent

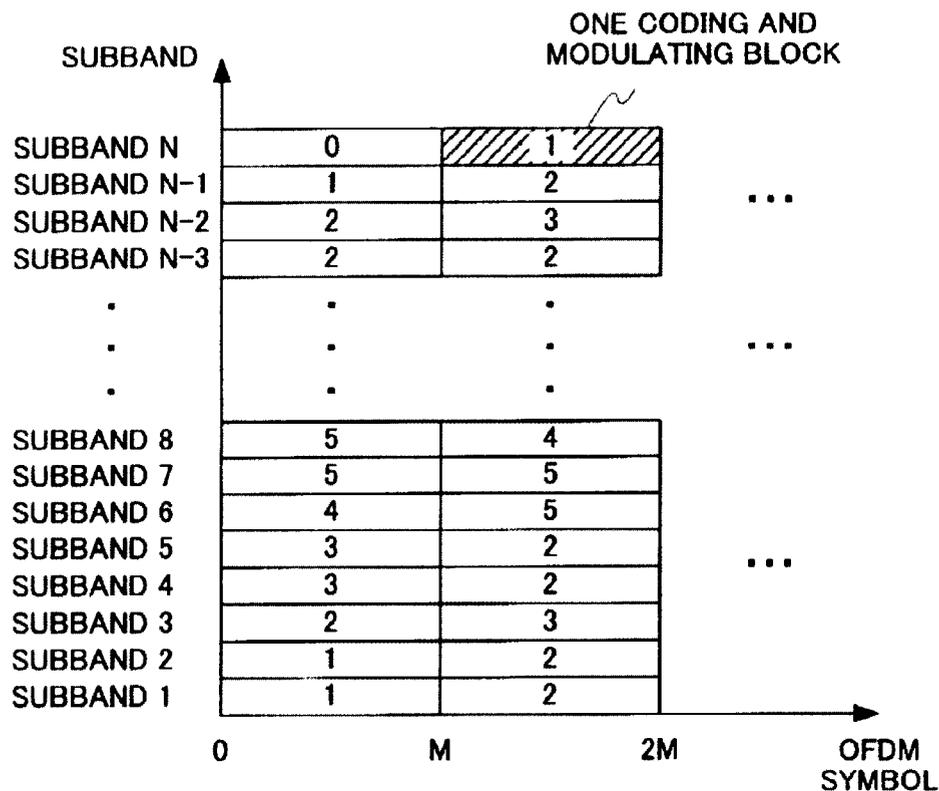

(*Id.* at Fig. 2.).

“Currently [in the prior art], as an adaptive configuration, AMC in OFDM is divided into ... AMC based on subcarriers and AMC based on subbands.” (*Id.* at 2:2-4.). According to the '439 patent, “AMC based on subcarriers is very difficult to be implemented, and, in addition, has the problem that feedback overhead is too large.” (*Id.* at 2:8-11.). “Compared to subcarrier adaptivity, the adaptive method using independent coding of subbands ... is able to effectively reduce the difficulty of implementation of adaptivity and is able to effectively reduce feedback

overhead of the system. However, even in this kind of method, there is the drawback that it is not possible to effectively utilize diversity performance between the subbands.” (*Id.* at 2:56-63.).

The ’439 patent purports to solve this problem. Specifically, the ’439 patent proposes “combining all of the subbands on a frequency domain of a subcarrier communication system based on a fixed rule ... to give several subband groups, and then selecting modulation and coding parameters for use during joint coding with respect to *each subband group.*” (*Id.* at 5:40-44 (emphasis added)). In other words, a device selects a single set of modulation and coding parameters for each subband group, and then uses those parameters to decode information received on those subbands. (*Id.* at 5:32-44.). Another way of framing the “invention” is that the ’439 patent extends AMC based on subcarriers and subbands as found in the prior art to AMC based on subband groups.

Figures 6 below depicts three different ways of combining subbands to form subband groups. The first way “shows an example of combining neighboring subbands.” (*Id.* at 10:38-39.). The second way shows “shows an example of combining subbands spaced at intervals.” (*Id.* at 10:55-56.). The third way “is an example of combining all of the subbands.” (*Id.* at 10:66-67.).

Figure 6: Figures 8 -10 of the '439 Patent Showing Formation of Subband Groups

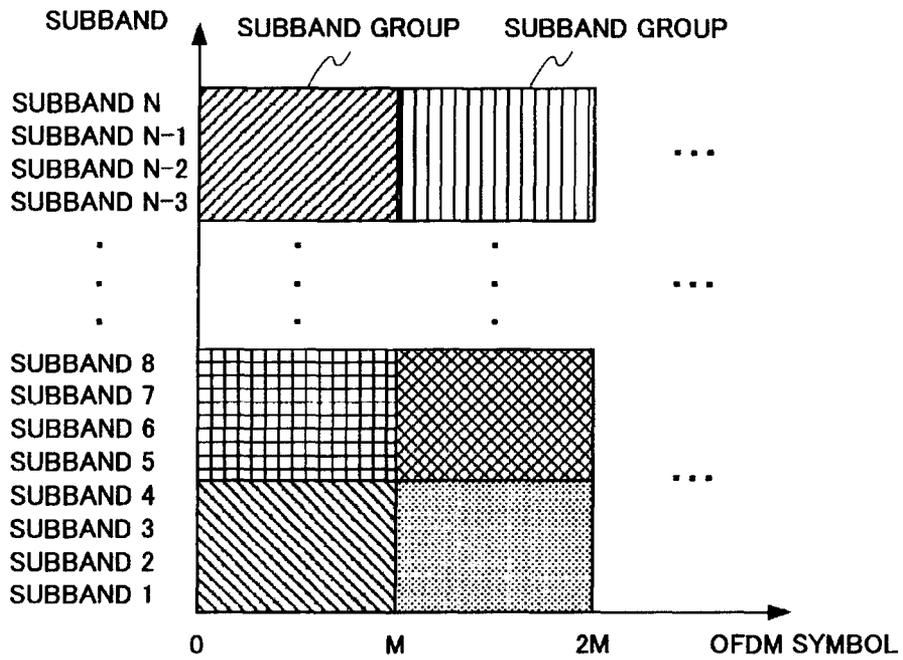

FIG.8

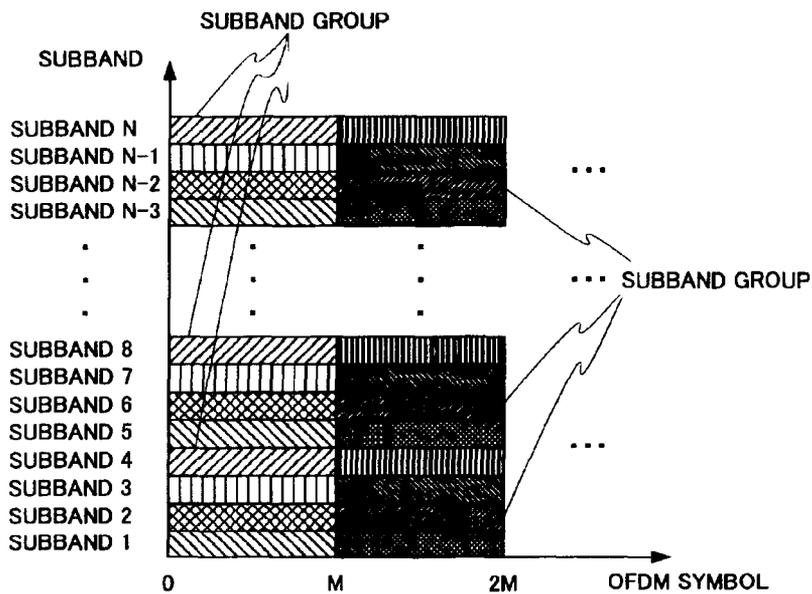

FIG.9

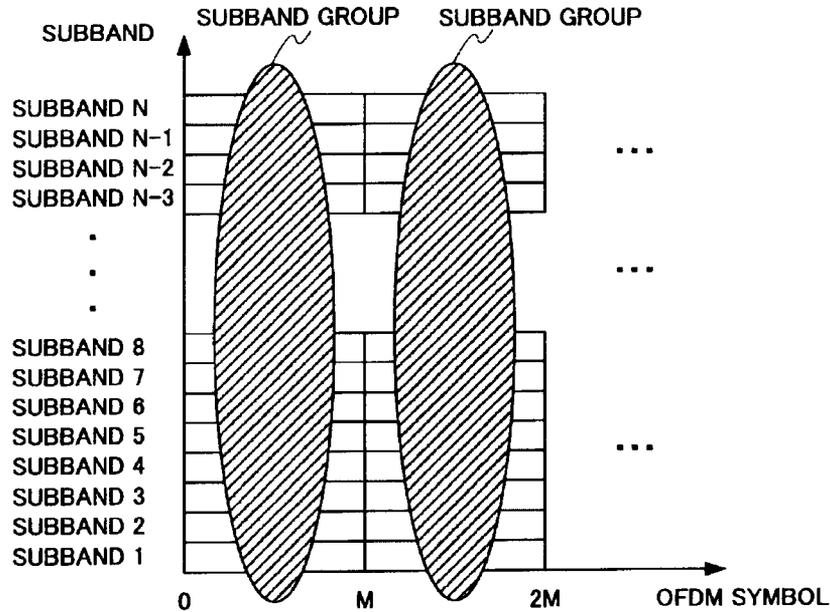

FIG.10

(Id., Figs. 8-10.).

2. Disputed Claim Term Constructions

a. “a parameter deciding section that . . .”

Claim(s) Term	Complainants' Proposed Construction	Respondents' Proposed Construction	Staff's Proposed Construction	Adopted Construction
<p>Respondents' Proposed Term For Construction: “a parameter deciding section that . . .”</p> <p>Full Term For Construction: “a parameter deciding section that decides modulation</p>	<p>The full term for construction is: “a parameter deciding section that decides modulation parameters and coding parameters per subband group comprised of a plurality of the subbands”</p>	<p>§ 112, ¶ 6 Function: “deciding modulation parameters and coding parameters per subband group comprised of a plurality of the subbands, based on a result of the channel</p>	<p>“a signal processor executing code operating in accordance with the claim language, circuitry operating in accordance with the claim language, or a combination</p>	<p>“hardware and/or software that decides modulation parameters and coding parameters per subband group comprised of a plurality of the subbands”</p>

Claim(s) Term	Complainants' Proposed Construction	Respondents' Proposed Construction	Staff's Proposed Construction	Adopted Construction
parameters and coding parameters per subband group comprised of a plurality of the subbands” (Claims 1, 2, 3)	This term is not subject to 35 U.S.C. § 112 ¶ 6; Plain and ordinary meaning: a digital signal processor (DSP) with code implemented, an application specific integrated circuit (ASIC), discrete circuitry and memory, and/or combinations thereof that decides modulation parameters and coding parameters per subband group comprised of a plurality of the subbands	estimation per subband” Structure: <i>Indefinite</i>	thereof”	

The “parameter deciding section” limitation does not use the word “means.” Thus, it is presumed that § 112 ¶ 6 does not apply. *Williamson*, 792 F.3d at 1349. Respondents bear the burden of overcoming that presumption. *Id.* As set forth below, Respondents have failed to carry their burden to show that the “parameter deciding section” limitation fails “to ‘recite[] sufficiently definite structure’ or else recites ‘function without reciting sufficient structure for performing that function.’” (*Id.* at 1348.).

According to claims 1, 2, and 3 of the ’439 patent, the “parameter deciding section” “decides modulation parameters and coding parameters per subband group.” This is a functional

statement addressing what the “parameter deciding section” does, not how it performs the function. Thus, based on an examination of claims 1, 2, and 3 of the ’439 patent in isolation, “parameter deciding section” appears to lack the structure needed to avoid § 112 ¶ 6 treatment.

However, the “parameter deciding section” limitation appears *verbatim* in the specification. (JXM-0005 (’439 Patent) at 6:7-10 (“a parameter deciding section that decides modulation parameters and coding parameters per subband group comprised of a plurality of subbands based on channel estimation results”).). The specification also refers to the similar concept of parameter selection. For example, Figures 5B and 6B of the ’439 patent show element 504, a “Subband AMD Parameter Selection” block, which receives channel quality estimation information from the “Channel Estimation” block 319, “selects AMC parameters for the subband group,” and passes those parameters to “Parameter Transmission” block 320 for transmission to a communicating party. (*Id.* at 7:60-64, Figs. 5B, 6B (“Subband group AMC parameter selection section 504 that is a parameter deciding section contained in module 505 shown in FIG. 5B selects AMC parameters for the subband group, ...”).).

Moreover, the specification appears to teach the operational contours of the “parameter deciding section” limitation. After addressing prior art methods of selecting modulation and coding parameters for subbands, the specification addresses “the number of information bits and joint coding parameters assigned within a subband group.” (*Id.* at 11:7-9.). The specification explains: “First, a modulation method where the sum of the number of information bits assigned within the subbands is obtained and the obtained number is taken to be the number of information bits assigned to the entire subband group. Next, the maximum modulation classifications within the subbands are made uniform in the subband groups and the result is used as a modulation scheme in modulation. Next, the coding rate is obtained from the number of

information bits assigned within the subband group and the modulation method.” (*Id.* at 11:9-18.). An explicit example of the algorithmic intricacies of a “parameter deciding section” in selecting modulation and coding parameters of a subband group is shown below in Figure 7.

Figure 7: '439 Patent's Exemplary Selection of Modulation and Coding Parameters for a Subband Group

In this process, it is assumed that, for example, there are four subbands A, B, C and D at one subband group, the number of subcarriers included at the subbands is 512, and that the classifications of coding and modulation corresponding to the subbands are 0, 1, 2, and 3 respectively. As a result, the number of information bits assigned within the subband groups of A, B, C and D are $512 \times 0 = 0$ for A, $512 \times 0.5 = 256$ for B, $512 \times 1 = 512$ for C, and $512 \times 1.5 = 768$ for D. Because of this, the total number of information bits within the subband group is $0 + 256 + 512 + 768 = 1536$. The highest modulation classification is then selected for the subband groups of A, B, C and D (here, the modulation classification corresponding to subband D is the highest), and 8PSK is taken to be a modulation parameter uniform over the whole of the subband group. Correspondingly, the coding rate used in coding in a uniform manner for the subband group is $1536 / (512 \times 3 \times 4) = 1/4$.

(*Id.* at 11:19-34.).

Moreover, the specification makes clear what the “invention” is and is not, and naturally devotes far more attention to the former. The “invention” pertains to the application of AMC to subband groups, not the creation of new AMC techniques *per se*. The “invention” treats as given underlining prior art AMC structures as previously applied to subcarriers and subbands. Against this backdrop, Respondents’ position appears to distill to a critique that the specification should have included more information about how to apply known, referenced, structure-providing AMC techniques to subband groups. If Respondents were to prevail, such that “parameter

deciding section” receives § 112 ¶ 6 treatment, it would greatly expand the scope of “purely functional claiming” and effectively write out the interpretive role of a person of ordinary skill.

This analysis dovetails with the prerogative of Respondents’ experts in co-pending Petitions for *Inter Partes* Review of the ’439 patent. (CXM-0007 (Singer ’439 Decl.) at ¶ 30; CXM-0009 (Ding ’439 Decl.) at ¶ 58.). For example, in his declaration, Dr. Zhi Ding, HTC Corporation and HTC America, Inc.’s expert, states that “it was well known in the art, before the earliest claimed priority date of the ’439 patent, to combine subbands into subband groups, to decide joint modulation and coding parameters for each subband group for the transmission side, to send the decided modulation and coding parameters for each subband group to the transmission side, and to store in advance patterns for combining subbands into subband groups by the receiving side as well as the transmission side.” (CXM-1009 (Ding ’439 Decl.) at ¶ 58.).

What remains is construction of “parameter deciding section.” None of the parties has offered a construction that hews to the intrinsic evidence. The specification does not mention the “digital signal processor (DSP) with code” or the “application specific integrated circuit (ASIC)” that appears in INVT’s proposed construction or the “signal processor executing code” that appears in Staff’s proposed construction. Respondents did not provide a construction other than the application of § 112, ¶ 6 and resulting indefiniteness. For similar reasons set forth above in the context of the “measuring” limitations of the ’587 and ’590 patents, the proper construction is “hardware and/or software” that performs the recited function.

b. “a data obtaining section that . . .”

Claim(s) Term	Complainants' Proposed Construction	Respondents' Proposed Construction	Staff's Proposed Construction	Adopted Construction
Respondents' Proposed	The full term for construction is:	§ 112, ¶ 6 Function:	“a signal processor	“hardware and/or software

<p>Term For Construction: “a data obtaining section that . . .”</p> <p>Full Term For Construction: “a data obtaining section that demodulates and decodes the received signal received at the receiving section on a per subband group basis using the modulation parameters and the coding parameters decided at the parameter deciding section” (Claim 1)</p>	<p>“a data obtaining section that demodulates and decodes the received signal received at the receiving section on a per subband group basis using the modulation parameters and the coding parameters decided at the parameter deciding section”</p> <p>This term is not subject to 35 U.S.C. § 112 ¶ 6; Plain and ordinary meaning: a digital signal processor (DSP) with code implemented, an application specific integrated circuit (ASIC), discrete circuitry and memory, and/or combinations thereof that demodulates and decodes the received signal received at the receiving section on a per subband group basis using the modulation parameters and the coding parameters decided at the parameter deciding section.</p>	<p>“demodulating and decoding the received signal received at the receiving section on a per subband group basis using the modulation parameters and the coding parameters decided at the parameter deciding section, and obtains the data contained in the received signal”</p> <p>Structure: <i>Indefinite</i> or, in the alternative, element 311 of Fig. 6B, including as discussed in 3:56-61, 4:52-55</p>	<p>executing code operating in accordance with the claim language, circuitry operating in accordance with the claim language, or a combination thereof”</p>	<p>that demodulates and decodes the received signal received at the receiving section on a per subband group basis using the modulation parameters and the coding parameters decided at the parameter deciding section”</p>
---	--	---	---	---

The “data obtaining section” limitation in claim 1 appears to be the counterpart of the “parameter deciding section” of the same claim. This is true insofar as the “data obtaining section” relates to demodulating and decoding a signal received by the user equipment (“UE”) from the base station, where the demodulation and decoding is done using the modulation and coding parameters previously decided by the “parameter determining section.” (JXM-0005 (’439 Patent), cl. 1.). For similar reasons as set forth above in the context of “parameter deciding section,” § 112, ¶ 6 does not apply to “data obtaining section.”

In the context of the ’439 patent, one of ordinary skill in the art would understand that “data obtaining section” connotes structure. The specification addresses adaptive demodulation and decoding in several places. In the context of the prior art, the ’439 patent recognizes that “adaptive transmission from the transmission side of FIG. 3A to the receiving side of FIG. 3B is implemented mainly by adaptive modulation/coding section 301 on the transmission side and *adaptive demodulating/decoding section 311 on the receiving side.*” (*Id.* at 3:14-18 (emphasis added).).

In the context of the “invention,” “on the receiving side, ... receiving control section 503” controls “*adaptive demodulating/decoding section 311* that is the data obtaining section,” “controls parallel/serial converter (P/S) 312 that is prior to adaptive demodulation and decoding, synthesizes received symbols within the same subband group, and carries out demodulation and decoding.” (*Id.* at 8:31-36 (emphasis added).). Here, the specification explicitly equates demodulating/decoding in the “invention” and prior art. That makes sense because the “invention” pertains to the application of AMC to subband groups, not the creation of new AMC techniques *per se*. The “invention” treats as given underlining prior art AMC structures as previously applied to subcarriers and subbands, including decoding and demodulation.

Respondents' experts appear to agree with this assessment in co-pending Petitions for *Inter Partes* Review of the '439 patent. (CXM-0007 (Singer '439 Decl.) at ¶ 30; CXM-0009 (Ding '439 Decl.) at ¶ 166.). For example, Dr. Ding stated in his Declaration that “[a] person of ordinary skill in the art would have understood that, to establish the data link between the base station and the subscriber, the subscriber would necessarily have a section to obtain the downlink data from the data link. Without the data obtaining section, the data link cannot be established. A POSITA would also have understood that the subscriber’s data obtaining section would necessarily have to demodulate and decode the received signals and obtain the data contained therein. That is the whole point of establishing the data link between the BS [base station] and the subscriber.” (CXM-0009 (Ding '439 Decl.) at ¶ 166.).

What remains is construction of “data obtaining section.” None of the parties has offered a construction that hews to the intrinsic evidence. The specification does not mention the “digital signal processor (DSP) with code” or the “application specific integrated circuit (ASIC)” that appears in INVT’s proposed construction or the “signal processor executing code” that appears in Staff’s proposed construction. Respondents did not provide a construction other than the application of § 112, ¶ 6. For similar reasons set forth above in the context of the “measuring” limitations of the '587 and '590 patents, the proper construction is “hardware and/or software” that performs the recited function.

3. Agreed-Upon Constructions

Claim(s) Term	Complainants' Proposed Construction	Respondents' Proposed Construction	Staff's Proposed Construction
Respondents' Proposed Term For Construction: “per subband” (Claims	Agreed: “for each subband”		

Claim(s) Term	Complainants' Proposed Construction	Respondents' Proposed Construction	Staff's Proposed Construction
1, 2, 3)			
Respondents' Proposed Term For Construction: "per subband group" (Claims 1, 2, 3)	Agreed: "for each subband group"		

C. '949 patent

1. Background

The '949 patent generally relates to a cellular communication system, including a base station and mobile UE, that implements an automatic-repeat request (ARQ) scheme. (JXM-0003 ('949 patent) at 1:4-10.). In that scheme, "[a]n ACK message informs the transmitter that the receiver was able to successfully decode" the transmission. By contrast, a "NAK message informs the transmitter of a decoding error." (*Id.* at 1:48-49.). The '949 patent addresses the coordination of sending ACK and NAK messages.

Figure 2 of the '949 patent (shown below in Figure 8) depicts a conventional ARQ scheme from the perspective of a receiver (e.g., UE in the form of a mobile phone). (*Id.* at 5:47-48.). "[T]ransmission from the base station to the mobile station (downlink transmission) is an asynchronous transmission whereas the uplink transmission, i.e. the feedback, is a synchronous transmission." (*Id.* at 3:43-47.). "Protocols for asynchronous transmission use an explicit signalling to identify a data block," such as "sequence numbers (SN), "whereas synchronous uplink protocols identify the feedback messages based on the time when they are received." (*Id.* at 3:50-56.).

Figure 8: Figure 2 of the '949 Patent

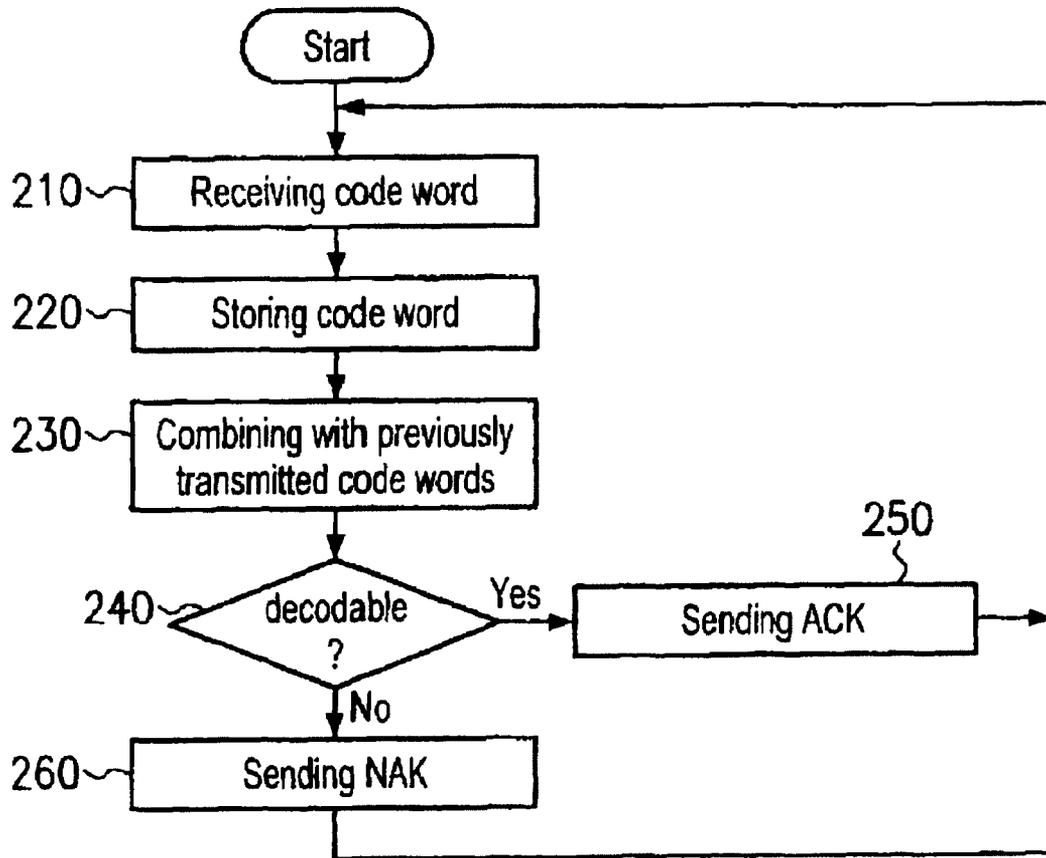

(*Id.*, Fig. 2.).

According to the '949 patent, this conventional arrangement presents several disadvantages. (*Id.* at 4:4-5:11.). Synchronous transmission of ACK/NAK messages is “inflexible because transmission has to be done at predefined time instances.” (*Id.* at 4:6-10.). This is undesirable, because the processing time needed for each mobile station may differ depending on the mobile station’s capabilities. (*Id.* at 41-58.). Asynchronous transmission, on the other hand, is not ideal. While it “can improve the throughput and delay performance and thus the flexibility of the system,” asynchronous transmission also “leads to a substantial signal overhead” by “requir[ing] a sequence number (SN) to be transmitted.” (*Id.* at 4:63-5:3.). Because asynchronous transmission “increases the power consumption and requires a more

complex user equipment,” asynchronous transmission “cannot provide an adequate solution of the problems with the synchronous feedback channel.” (*Id.* at 5:7-11.).

“Given the above problems, it is the object of the invention to ... allow[] for flexible timing of the ACK/NAK messages without signalling overhead.” (*Id.* at 5:12-15.). In layman’s terms, as shown below in Figure 9, the ’949 patent teaches a hybrid approach that purports to capture the advantages of synchronous and asynchronous transmission while minimizing the attendant costs of those methods. (*Id.* at 10:17-19 (“the invention combines the advantageous of synchronous and asynchronous transmission.”)). Specifically, the “invention” uses “multiple predetermined time intervals in the feedback channel for transmitting the acknowledgement [ACK/NAK] messages where the used time intervals of the feedback channel unambiguously correspond to the respective forward channel time intervals[.]” (*Id.* at 5:19-23.). In other words, the ’949 patent’s “improved” ARQ scheme incorporates the low overhead of a synchronous scheme by limiting feedback messages to multiple pre-determined time intervals, while also providing some asynchronous-like flexibility in terms of selecting the time interval used to send a feedback message.

Figure 9: Figure 5b of the '949 Patent

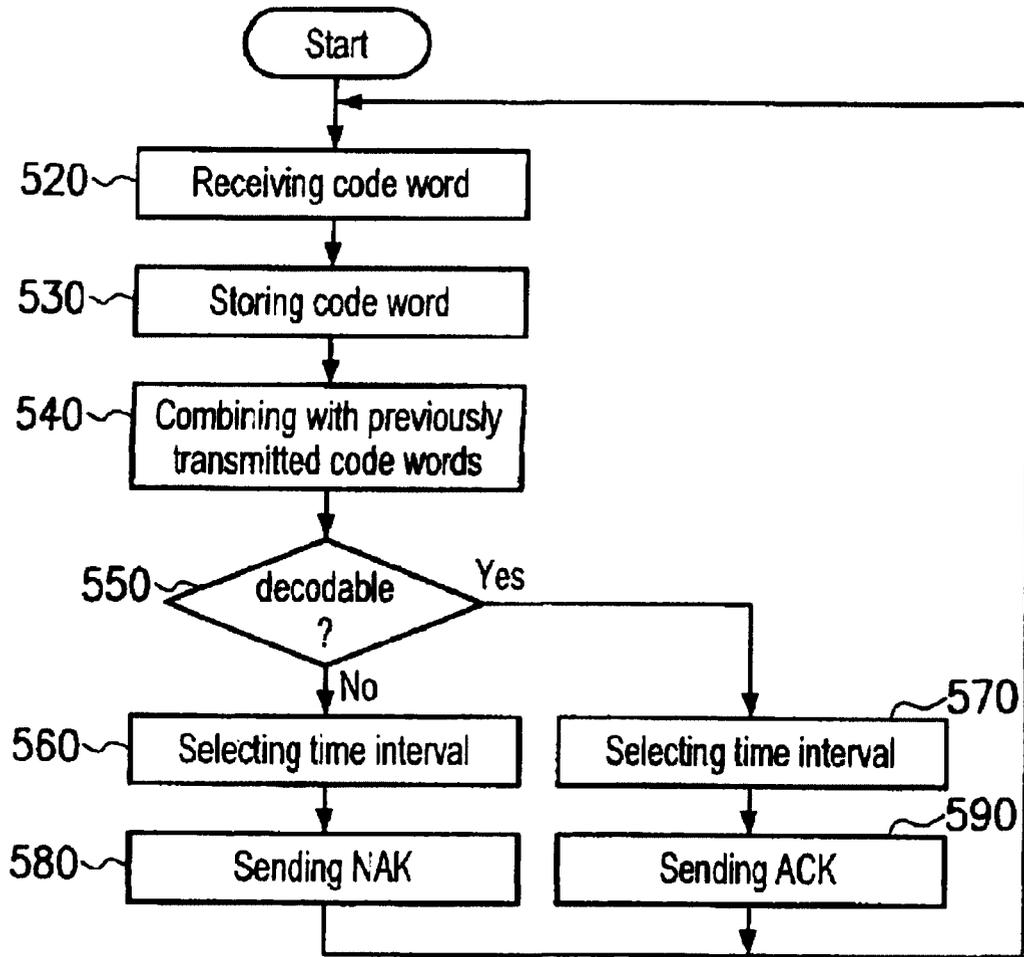

(Id., Fig. 5b.).

2. Disputed Claim Term Construction

Claim(s) Term	Complainants' Proposed Construction	Respondents' Proposed Construction	Staff's Proposed Construction	Adopted Construction
<p>Respondents' Proposed Term For Construction: "a selection section for ..."</p>	<p>The full term for construction is: "a selection section for selecting, for each received encoded data packet, one of at</p>	<p>§ 112, ¶ 6 Function: "selecting, for each received encoded data packet, one of at least two second time intervals for</p>	<p>"a signal processor executing code operating in accordance with the claim language, circuitry</p>	<p>§ 112, ¶ 6 applies Function: "selecting, for each received encoded data</p>

Claim(s) Term	Complainants' Proposed Construction	Respondents' Proposed Construction	Staff's Proposed Construction	Adopted Construction
<p>Full Term For Construction: “a selection section for selecting, for each received encoded data packet, one of at least two second time intervals for transmission of the acknowledgment message, wherein: said selection section selects, from said at least two second time intervals, a time interval dependent on the physical resources that have been allocated, such as frequencies, codes and time slots.” (Claim 16)</p>	<p>least two second time intervals for transmission of the acknowledgment message, wherein: said selection section selects, from said at least two second time intervals, a time interval dependent on the physical resources that have been allocated, such as frequencies, codes and time slots.”</p> <p>This term is not subject to 35 U.S.C. § 112 ¶ 6; Plain and ordinary meaning: a digital signal processor (DSP) with code implemented, an application specific integrated circuit (ASIC), discrete circuitry and memory, and/or combinations thereof for selecting, for each received encoded data</p>	<p>transmission of the acknowledgment message”</p> <p>Structure: <i>Indefinite</i></p>	<p>operating in accordance with the claim language, or a combination thereof”</p>	<p>packet, one of at least two second time intervals for transmission of the acknowledgment message” and “select[ing], from said at least two second time intervals, a time interval dependent on the physical resources that have been allocated, such as frequencies, codes and time slots.”</p> <p>Structure: Element 510 of Fig. 5A, including as discussed in 7:3-11, and “physical resources that have been allocated, such as frequencies, codes and time slots” explicitly disclosed in the specification, and equivalents thereof.</p>

Claim(s) Term	Complainants' Proposed Construction	Respondents' Proposed Construction	Staff's Proposed Construction	Adopted Construction
	packet, one of at least two second time intervals for transmission of the acknowledgment message, wherein: said selection section selects, from said at least two second time intervals, a time interval dependent on the physical resources that have been allocated, such as frequencies, codes and time slots			

The “selection section” limitation does not use the word “means.” Thus, it is presumed that § 112 ¶ 6 does not apply. *Williamson*, 792 F.3d at 1349. Respondents bear the burden of overcoming that presumption. *Id.* As set forth below, Respondents carried the burden of showing that § 112 ¶ 6 applies. Yet, they failed to establish that “selection section” lacks corresponding structure in the specification and, thus, is indefinite.

“Selection section” is not found *verbatim* in the specification. However, the specification does disclose that, as shown below in Figure 10, “the receiver of FIG. 5a includes a time interval selector 510 that receives the control signal from the decoder 165 and is used for selecting the earliest possible sub-TTI for transmitting the acknowledgement message.” (JXM-0003 (‘949 patent) at 7:3-6.). Claim 16 bases time interval selection “on the *physical resources* that have

been allocated, such as frequencies, codes and time slots.” (*Id.*, cl. 16 (emphasis added)).

Importantly, claim 16 is satisfied by any “physical resources” and not limited to “frequencies, codes and time slots” identified as examples of such resources.

Figure 10: Figure 5a of the '949 Patent

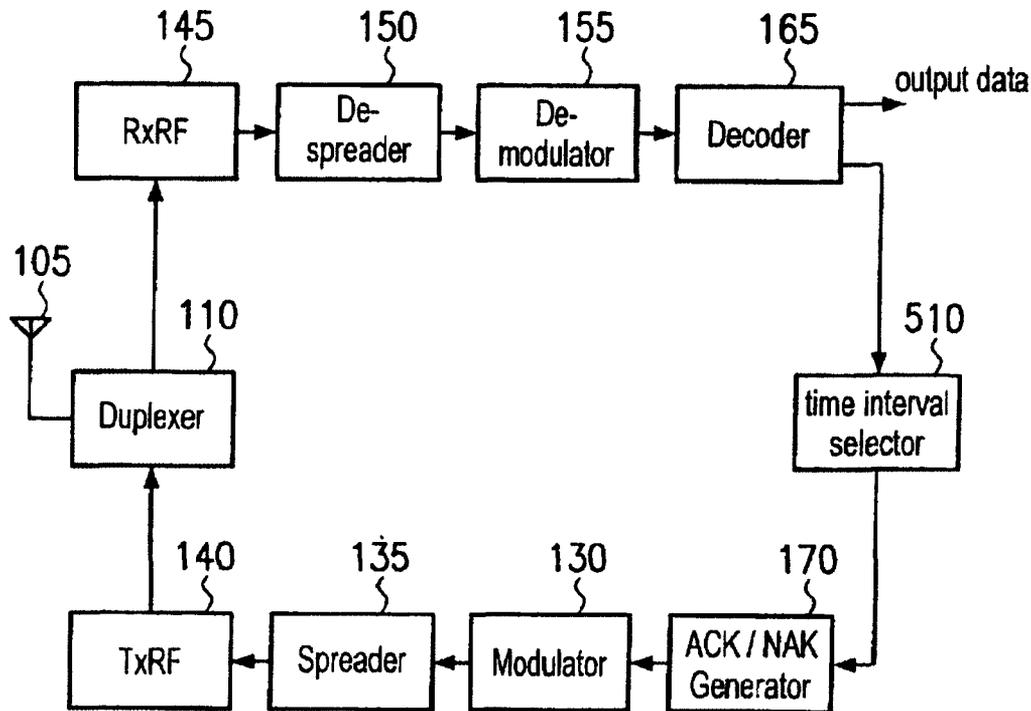

(*Id.*, Fig. 5a.).

This makes “physical resources” a term of great interest. The specification gives examples of “physical resources,” such as “a number of codes in CDMA or a number of frequencies in FDMA,” and how they affect the selection of time intervals. (*Id.* at 8:67-9:5.). The specification explains that “different combinations of coding and modulation will be referred to as Modulation Coding Scheme (MCS) levels” and that “MCS level could change with each TTI.” (*Id.* at 2:62-66.). With such “adaptive modulation and coding (AMC),” “[d]epending on the channel conditions, different MCS levels will be selected” and “processing time strongly depends on the amount of received data and on the demodulation/decoding scheme that has to be

applied.” (*Id.* at 4:44-48.). In other words, “the invention allows for operating different kinds of receivers having low as well as high processing times” insofar as a “slowly processing receiver will then use a different time interval compared with a faster receiver.” (*Id.* at 5:23-26.).

Yet, even with the benefit of specification’s interpretative guidance, claim 16 lacks the underlying algorithmic structure by which UE identifies a timeslot to select, particularly the physical resources that the algorithm draws upon to make its selection. Consequently, § 112 ¶ 6 applies to “selection section” as used in claim 16.

This is evident when the “selection section” language of claim 16 is compared to similar language from claim 15. Claim 16 requires only a “selection section” that “selects, from said at least two second time intervals, a time interval dependent on the physical resources that have been allocated, such as frequencies, codes and time slots.” (*Id.*, cl. 16.). As indicated above, claim 16 is satisfied by the selection of any time interval based on any “physical resource” where some relationship exists between the chosen time interval and allocated physical resources.

By contrast, in claim 15, “selection section selects, from said at least two second time intervals, a later time interval when a high modulation coding scheme level has been transmitted.” (*Id.*, cl. 15.). Claim 15 specifies algorithmic structure in the form of the time interval selected (later), the physical resource used (modulation coding scheme), and the relationship between the two (later time interval corresponds to high modulation scheme).

Claim 16 does not provide any such structure. One could rewrite the “selection section” term as follows without changing its meaning: “means for selecting, for each received encoded data packet, one of at least two second time intervals for transmission of the acknowledgment message, wherein: said means selects, from said at least two second time intervals, a time interval dependent on the physical resources that have been allocated, such as frequencies, codes

and time slots.” Therefore, § 112 ¶ 6 applies to the term “selection section” in claim 16, limiting coverage of the term to disclosed embodiments.

Yet, disclosed embodiments of the ’949 patent do not clearly illuminate how “selection section” operates to make selections. Instead, they describe what the “selection section” may do and cannot do in terms of making selections. Specifically, “[a] mobile station that *can* process received encoded data at high speed will therefore be allowed to send an ACK/NAK message back to the transmitter immediately after the processing result is obtained.” (*Id.* at 7:22-26 (emphasis added)). Moreover, “[u]ser equipment that operates more slowly would not be in the position to transmit the ACK/NAK message in the first possible sub-TTI 610, 640, 670 because it requires a higher processing time[.]” (*Id.* at 7:26-29.). Left unsaid is specifically how “selection section” selects a timeslot for that “[u]ser equipment that operates more slowly” or, for that matter, for UE that operates swiftly. Those algorithmic details are simply omitted.

Against this backdrop, the “selection section” claim term is either “reasonably certain[]” in scope yet broad or, on the other hand, indefinite. *Nautilus*, 134 S.Ct. at 2129. This is a close call. Because the ability to select a sub-TTI lies at the heart of the “invention,” one would expect more algorithmic clarity from the specification with respect to how to select a sub-TTI. Yet, the ’949 patent clearly touts, and attempts to preserve, flexibility in terms of how sub-TTI selection occurs: “The invention is therefore applicable to different system design approaches” and “[t]he scheme according to the invention can be considered as being a synchronous uplink transmission where flexibility is added by opening the possibility of sending ACK/NAK signals in various sub-TTI’s.” (*Id.* at 9:4-5, 10:50-53.). The disclosed embodiments showcase the diversity of timeslot arrangements from which timeslot selection can occur.

The inventors clearly envisioned that their “invention” would have broad applications: “Further embodiments of the invention are based on the development of new generation mobile communications systems that will be very flexible and will allow the support of all kind of services. Furthermore they will be adaptable to the radio channel, thereby increasing the user and system throughput. Thus, there might be several dimensions in which a system is flexible.” (*Id.* at 8:51-57.). It appears that claim 16 was an attempt to capture all of the present and future ways of flexibly selecting sub-TTIs. Yet, as explained above, the patentees could not achieve this breadth of effectively structure-less claim scope without running afoul of § 112 ¶ 6.²

Nevertheless, when confined by § 112 ¶ 6, the “selection section” term of claim 16 appears to “inform those skilled in the art about the scope of the invention with reasonable certainty.” *Nautilus*, 134 S.Ct. at 2129. As explained above, already known in the art was AMC or the changing of modulation and coding in accordance with variations in the channel conditions. Also known was the association of Modulation Coding Scheme (MCS) levels (different combinations of coding and modulation) with TTIs, “where the MCS level could change each TTI.” The specification fleshes out “frequencies, codes, time slots” covered in claim 16 by specifying physical resources used to select a sub-TTI, namely “a number of codes in CDMA or a number of frequencies in FDMA,” UMTS, and HSDPA. The disclosed embodiments in the specification further suggest, without requiring, that sub-TTI selection would occur at the earliest possible time, such that high-speed UEs use earlier-available sub-TTIs and low-speed UEs use later-available sub-TTIs. In short, the inventors chose to disclose embodiments that were broad and flexible, and, when confined to those embodiments, the scope

² To be clear, the act of selecting a timeslot in claim 16 appears unremarkable as a function performed by a computer. *Katz*, 639 F.3d at 1316. However, what appears remarkable and not adequately addressed by claim 16 when interpreted as a non-means-plus-function claim is the underlying algorithmic structure by which UE identifies a timeslot to select, including physical resources that the algorithm draws upon.

of claim 16 is broad but reasonably certain and thus not indefinite. *BASF Corp. v. Johnson Matthey Inc.*, 875 F. 3d 1360, 1367 (Fed. Cir. 2017) (“the inference of indefiniteness simply from the scope finding is legally incorrect: ‘breadth is not indefiniteness.’”).

Consequently, Respondents have failed to prove by clear and convincing evidence that “selection section” is indefinite.

3. Agreed-Upon Constructions

In their Joint CC Chart, the Parties did not present an agreed-upon construction of a claim term in the '949 patent.

VI. PROCEEDINGS GOING FORWARD

A. Supplementation in Response to This Order

The Parties may not file supplemental expert reports in response to this Order. No additional discovery will be permitted because of this Order unless allowed by leave of court and requested by motion. No re-argument of the scope of the claims construed in this Order may occur.

Going forward, and consistent with Ground Rules in this Investigation, the Parties are expected *to notify Chambers of any issues that have become moot, or have been eliminated for any reason within five (5) days of such a change*. The Parties should redact from expert reports and from any other documents upon which they intend to rely any issues, claims, defenses, prior art, theories, or any other content that has been rendered moot or disallowed as a result of this or other Orders, or because of the termination of patent claims or allegations from this Investigation. Any expert reports that are changed or redacted because issues have become moot should be filed on EDIS and two (2) copies should be provided to Chambers before the Hearing.

B. Streamlining the Investigation

To the extent that this *Markman* Order will enable the Parties to streamline this Investigation, such as through the elimination of asserted claims or asserted prior art, the Parties are encouraged to take action now. INVT is encouraged to drop patents and claims from this Investigation. Moreover, Respondents should be notified now which patents/claims will be eliminated so that they (and the Court) do not waste unnecessary resources preparing to address patents or claims that will be dropped. Identifying additional patents/claims that will be dropped will also give Respondents time to eliminate invalidity theories. If certain of Respondents' theories and prior art are now moot because of the adopted constructions, Respondents should notify INVT and make the appropriate filings on EDIS and to Chambers.

C. Settlement

It is strongly recommended that, in advance of the Hearing and in light of this *Markman* Order, the Parties take informal opportunities to engage in settlement.

VII. CONCLUSION

Constructions of the disputed claim and agreed-upon terms are hereby adopted by this Order for the reasons discussed herein.

SO ORDERED.



MaryJoan McNamara
Administrative Law Judge

PUBLIC CERTIFICATE OF SERVICE

I, Lisa R. Barton, hereby certify that the attached **ORDER** has been served by hand upon the Commission Investigative Attorney, **Reginald Lucas, Esq.**, and to the following parties as indicated, on **July 15, 2019**.



Lisa R. Barton, Secretary
U.S. International Trade Commission
500 E Street, SW, Room 112
Washington, DC 20436

On Behalf of Complainant INVT SPE LLC:

Bryan J. Vogel, Esq.
ROBINS KAPLAN LLP
399 Park Avenue, Suite 3600
New York, NY 10022

- Via Hand Delivery
- Via Express Delivery
- Via First Class Mail
- Other: _____

On Behalf of Respondent Apple Inc.:

Robert A. Appleby, P.C.
KIRKLAND & ELLIS LLP
601 Lexington Avenue
New York, NY 10022

- Via Hand Delivery
- Via Express Delivery
- Via First Class Mail
- Other: _____

**On Behalf of Respondents HTC Corporation and HTC
America, Inc.:**

Stephen S. Korniczky, Esq.
SHEPPARD, MULLIN, RICHTER & HAMPTON LLP
12275 El Camino Real, Suite 200
San Diego, CA 92130

- Via Hand Delivery
- Via Express Delivery
- Via First Class Mail
- Other: _____

**On Behalf of Respondents ZTE Corporation and ZTE (USA)
Inc.:**

Jay H. Reiziss, Esq.
McDERMOTT WILL & EMERY LLP
500 North Capitol Street, NW
Washington, DC 20001

- Via Hand Delivery
- Via Express Delivery
- Via First Class Mail
- Other: _____