

In the Matter of

**CERTAIN UNITARY ELECTROMAGNETIC  
FLOWMETERS WITH SEALED COILS**

**Investigation No. 337-TA-230**

**USITC PUBLICATION 1924**

**NOVEMBER 1986**



# **UNITED STATES INTERNATIONAL TRADE COMMISSION**

## **COMMISSIONERS**

**Susan Liebeler, Chairman**  
**Anne E. Brunsdale, Vice Chairman**  
**Paula Stern**  
**Alfred E. Eckes**  
**Seeley G. Lodwick**  
**David B. Rohr**

**Address all communications to**  
**Kenneth R. Mason, Secretary to the Commission**  
**United States International Trade Commission**  
**Washington, DC 20436**

UNITED STATES INTERNATIONAL TRADE COMMISSION  
Washington, DC 20436

OFFICE OF THE SECRETARY  
DOLE / HSIC

96 OCT 30 P 4: 33

Re: [illegible]

In the Matter of )  
 )  
CERTAIN UNITARY ELECTROMAGNETIC )  
FLOWMETERS WITH SEALED COILS )

Investigation No. 337-TA-230

NOTICE OF COMMISSION DETERMINATION TO REVERSE PARTS OF  
INITIAL DETERMINATION; TERMINATION OF INVESTIGATION ON THE BASIS  
OF NO VIOLATION OF SECTION 337 OF THE TARIFF ACT OF 1930

AGENCY: U.S. International Trade Commission.

ACTION: Determination of no violation of section 337 of the Tariff Act of 1930, 19 U.S.C. § 1337, in the above-captioned investigation.

SUMMARY: The Commission has determined to reverse those parts of the initial determination (ID) of the administrative law judge (ALJ) finding an effect of substantial injury and a tendency to substantially injure the domestic industry in the above-captioned investigation. The investigation is therefore terminated on the basis that there is no violation of section 337.

FOR FURTHER INFORMATION CONTACT: Jean A. Heck, Esq., Office of the General Counsel, U.S. International Trade Commission, telephone 202-523-1693.

SUPPLEMENTARY INFORMATION: On September 24, 1985, Fischer & Porter Co. filed a complaint under section 337. On October 21, 1985, the Commission instituted an investigation to determine whether there is a violation of section 337 in the unlawful importation or sale of certain electromagnetic flowmeters with sealed coils into the United States by reason of alleged infringement of claims 1,2,3,4, and 5 of U.S. Letters Patent 4,420,982, the effect or tendency of which is to destroy or substantially injure an industry, efficiently and economically operated, in the United States. The Commission named Krohne Messtechnik GmbH & Co. of the Federal Republic of Germany and Krohne-America, Inc., of Peabody, Massachusetts, as respondents.

On July 30, 1986, the ALJ issued an ID finding a violation of section 337. On September 15, 1986, the Commission determined to review the effect of substantial injury and tendency to substantially injure portions of the ID (51 F.R. 33933). All parties submitted briefs on all issues under review and on remedy, the public interest, and bonding. No other submissions were received.

The authority for the Commission's disposition of this matter is contained in section 337 of the Tariff Act of 1930 (19 U.S.C. § 1337) and in section 210.56 of the Commission's Rules of Practice and Procedure (49 F.R. 46123) (19 CFR § 210.56).

Copies of the Commission's Action and Order and all other nonconfidential documents filed in connection with this investigation are available for inspection during official business hours (8:45 a.m. to 5:15 p.m.) in the Office of the Secretary, U.S. International Trade Commission, 701 E Street NW., Washington, DC 20436, telephone 202-523-0161. Hearing-impaired individuals are advised that information on this matter can be obtained by contacting the Commission TDD terminal on 202-724-0002.

By order of the Commission.

A handwritten signature in black ink, appearing to read 'K. Mason', is written over a horizontal line.

Kenneth R. Mason  
Secretary

Issued: October 30, 1986

UNITED STATES INTERNATIONAL TRADE COMMISSION  
Washington, D C 20436

\_\_\_\_\_  
In the Matter of )

CERTAIN UNITARY ELECTROMAGNETIC )  
FLOWMETERS WITH SEALED COILS )  
\_\_\_\_\_ )

Investigation No. 337-TA-230

COMMISSION ACTION AND ORDER

Background

On September 24, 1985, a complaint was filed with the Commission under section 337 on behalf of complainant Fischer & Porter Co. of Horsham, Pennsylvania, naming Krohne Messtechnik GmbH & Co., of Duisberg, Federal Republic of Germany, and Krohne-America, Inc., of Peabody, Massachusetts, as respondents. On October 21, 1985, the Commission voted to institute an investigation to determine whether there is a violation of section 337 in the unlawful importation or sale of certain electromagnetic flowmeters with sealed coils by reason of alleged infringement of claims 1,2,3,4, and 5 of U.S. Letters Patent 4,420,982 (the '82 patent), the effect or tendency of which is to destroy or substantially injure an industry, efficiently and economically operated, in the United States.

On July 30, 1986, the administrative law judge (ALJ) issued an initial determination (ID) finding a violation of section 337. On September 15, 1986, the Commission determined to review the issues of effect and tendency to substantially injure (51 F.R. 33933). All parties have submitted briefs on all issues under review, as well as on the issues of remedy, the public interest, and bonding. No other submissions were received.

## Action

Having considered the ALJ's ID, the briefs of the parties, and the record in this investigation, the Commission determined to reverse the part of the ALJ's ID finding that the domestic industry has been substantially injured and the part of the ID finding that there is a tendency to injure the domestic injury. Accordingly, the Commission determined to terminate the investigation on the basis that there is no violation of section 337.

For those issues addressed in the ALJ's ID that the Commission determined not to review, the ID has become the decision of the Commission.

## Order

Accordingly, it is hereby ORDERED THAT -

1. The parts of the ALJ's ID finding substantial injury to the relevant domestic industry and a tendency to substantially injure the relevant domestic industry are reversed;
2. Investigation No. 337-TA-230 is terminated on the basis that there is no violation of section 337; and
3. The Secretary shall serve copies of this Action and Order and the Commission opinions issued in connection therewith upon each party of record in this investigation and upon the Department of Health and Human Services, the Department of Justice, the Federal Trade Commission, and the U.S. Customs Service, and the Commission shall publish notice thereof in the Federal Register.

By order of the Commission.



Kenneth R. Mason  
Secretary

Issued: October 30, 1986

CERTIFICATE OF SERVICE

I, Kenneth R. Mason, hereby certify that the attached NOTICE OF COMMISSION DETERMINATION was served upon Juan Cockburn, Esq., and Gary Rinkerman, Esq., and upon the following parties via first class mail on October 31, 1986.

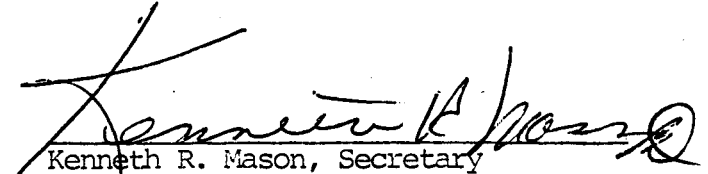
  
Kenneth R. Mason, Secretary  
U.S. International Trade Commission  
701 E Street, N.W.  
Washington, D.C. 20436

For Complainant Fischer & Porter Company:

John M. Calimafde, Esq.  
HOPGOOD, CALIMAFDE, KALIL, BLAUSTEIN & JUDLOWE  
Lincoln Bldg.  
60 East 42nd Street  
New York, NY 10165

For Respondents Krohne-America, Inc. and  
Krohne Messtechnik GmbH & Company KG:

Tom M. Schaumberg, Esq.  
PLAIA & SCHAUMBERG  
1019 19th St., N.W., PH-2  
Washington, D.C. 20036

Robert A. Cesari, Esq.  
CESARI AND MCKENNA  
Union Wharf East  
Boston, MA 02109

GOVERNMENT AGENCIES:

Mr. Charles S. Stark  
Antitrust Div, /U.S. Dept of Justice  
Room 7115, Main Justice  
Pennsylvania Avenue & Tenth Street, N.W.  
Washington, D.C. 20530

Edward F. Glynn, Jr., Esq.  
Asst Dir for Intl Antitrust  
Federal Trade Commission  
Room 502-4, Logan Building  
Washington, D.C. 20580

Darrel J. Grinstead, Esq.  
Dept of Health & Human Svcs.  
Room 5362, Noeth Building  
330 Independence Avenue, S.W.  
Washington, D.C. 20201

Michael T. Schmitz, Esq.  
Chief Counsel  
U.S. Customs Service  
1301 Constitution Avenue, N.W.  
Washington, D.C. 20229



PUBLIC VERSION

UNITED STATES INTERNATIONAL TRADE COMMISSION  
Washington, D.C. 20436

In the Matter of  
CERTAIN UNITARY  
ELECTROMAGNETIC FLOWMETERS

Investigation No. 337-TA-230

NOV 17 4:09  
OFFICE OF THE SECRETARY  
DOMESTIC POLICY

COMMISSION MEMORANDUM OPINION <sup>1/</sup>

Views of Commissioners Stern, Eckes,  
Lodwick, and Rohr

This investigation, conducted under section 337 of the Tariff Act of 1930, <sup>2/</sup> was instituted on the basis of a complaint filed by Fischer and Porter Company (F&P). The complaint alleged unfair practices in the importation and sale of certain unitary electromagnetic flowmeters by Krohne-Messtechnik GmbH and Krohne-America, Inc. (collectively referred to as Krohne), the alleged effect or tendency of which is to destroy or substantially injure an industry, efficiently and economically operated, in the United States. The unfair practice alleged was direct infringement of

<sup>1/</sup> The following abbreviations are used in this opinion:

- ALJ = Administrative Law Judge
- CX = Complainant's Exhibit
- IA = Commission Investigative Attorney
- ID = Initial Determination
- RX = Respondents' Exhibit
- TR = Transcript of Evidentiary Hearing.

<sup>2/</sup> 19 U.S.C. § 1337.

claims 1, 2, 3, 4, and 5 of the F&P's U.S. Letters Patent 4,420,982 (the '982 patent), in the sale and importation of certain unitary electromagnetic flowmeters. <sup>3/</sup>

On July 30, 1986, the ALJ filed an ID finding a violation of section 337 in the above-captioned investigation. <sup>4/</sup> The ALJ found F&P's patent to be valid and enforceable and infringed by electromagnetic flowmeters sold and imported by Krohne. He also found a domestic industry consisting of F&P's facilities devoted to the research, development, manufacture, marketing, and servicing of flangeless electromagnetic flowmeters made in accordance with the '982 patent. The ALJ found the domestic industry to be efficiently and economically operated. Moreover, the ALJ found that respondents' imports had the effect and tendency to destroy or substantially injure the domestic industry. The ALJ, therefore, found a violation of section 337.

Respondents petitioned for review of the patent and injury issues in the ID. Complainant and the IA filed replies. On September 15, 1986, the Commission ordered review of the issues of whether the importation or sale of Krohne's electromagnetic flowmeters had the effect or tendency to destroy or substantially injure an industry in the United States <sup>5/</sup>. The parties filed their respective submissions on those issues as well as on remedy, the public

---

<sup>3/</sup> 50 Fed. Reg. 45175-45176 (October 30, 1985).

<sup>4/</sup> The procedural history of this investigation up to the filing of the ID is recounted in the ID itself (ID pages 1-4).

<sup>5/</sup> 51 Fed. Reg. 33933 (September 24, 1986).

interest, and bonding. Complainant and respondents filed their respective replies. No other submissions were received. On October 30, 1986, the Commission determined to reverse the ALJ's conclusion of a violation of section 337.

EFFECT OF THE COMMISSION'S DETERMINATION

The Commission has determined on review to reverse the ALJ's findings on the effect and tendency to substantially injure the domestic industry. The effect of the Commission's determination is to find no violation of section 337 in this investigation.

Those findings of fact and conclusions of law in the ID which were not reviewed have become the Commission's determination pursuant to 19 C.F.R. § 210.53(h). The ALJ's conclusions of law concerning effect and tendency to substantially injure have been reversed. The ALJ's findings of fact concerning injury have been adopted only to the extent that they are not inconsistent with the Commission's determination or this Opinion.

Thus, the Commission has found that (1) F&P's '982 patent is valid and enforceable; (2) certain electromagnetic flowmeters sold and imported by Krohne infringe the '982 patent, (3) there is a domestic industry consisting of F&P activities under the '982 patent, (4) the domestic industry is efficiently and economically operated, and (5) the importation and sale of flowmeters by Krohne does not have the effect or tendency to destroy or substantially injure the domestic industry. Consequently, the Commission has determined that there is no violation of section 337 in this investigation.

## DISCUSSION

1. Introduction

F&P manufactures two models of flowmeter under the '982 patent, the MINI-MAG and the K-MAG. These flowmeters have flow tubes with diameters ranging from 1/10 to 4 inches. <sup>6/</sup> Complainant's MINI-MAG flowmeter has a flow tube coated with a teflon-like material and an overall accuracy rating of 1.0 percent. <sup>7/</sup> Its K-MAG has a ceramic flow tube and an overall accuracy rating of 1.0 percent. <sup>8/</sup> The imported flowmeters, the ALTO-FLUX and the DELTA-FLUX models, both have ceramic flow tubes. <sup>9/</sup> The overall accuracy of the DELTA-FLUX is 2 percent and that of the ALTO-FLUX is 0.5 percent. <sup>10/</sup> Although both of complainant's models have size ranges of from 1/10 inch to 4 inches in diameter, only complainant's MINI-MAG and K-MAG models with flow

---

<sup>6/</sup> FF 5, CX-36, CX-37.

<sup>7/</sup> FF 450, FF 509.

<sup>8/</sup> FF 451, FF 509.

<sup>9/</sup> RX-1. Respondents argued extensively before the ALJ and the Commission that customer preference for their product is due to its ceramic flow tube and sintered-in platinum electrode construction rather than due to any of the features patented by the complainant. Respondents contend that any injury done to complainant is due to customer preference for features not covered by the patent. Thus, respondents argue there is no nexus between the alleged unfair act and any injury to the complainant. Respondents also argued that any injury to complainant is due to complainant's defective products, poor service, and inadequate marketing. In view of our findings on injury, we do not find it necessary to reach these issues.

<sup>10/</sup> FF 509.

tubes of from 2 to 4 inches in diameter are made in accordance with the '982 patent, <sup>11/</sup> and only DELTA-FLUX and ALTO-FLUX flowmeters with diameters of from 2 to 4 inches were found to infringe that patent. <sup>12/</sup>

In its complaint, filed September 24, 1985, F&P asserted that only the MINI-MAG model was made in accordance with the '982 patent. The K-MAG model, on the market since early 1985, <sup>13/</sup> was not mentioned in the complaint. At the time that F&P filed its complaint, F&P's position was that all of its MINI-MAG models were made in accordance with the '982 patent. Prior to the start of the evidentiary hearing, and after discovery had been completed, complainant stipulated that only MINI-MAG and K-MAG models with flow tubes of diameters greater than two inches were made in accordance with the '982 patent. <sup>14/</sup>

Given the evidentiary stipulation, the ALJ properly held that the domestic industry consisted of F&P's activities concerning its electromagnetic flowmeters having flow tubes with diameters of from 2 to 4 inches. Complainant, however, only submitted data concerning the sales, profitability,

---

<sup>11/</sup> FF 5, RX-113 at Stipulation 5.

<sup>12/</sup> ID 51, ID 63, ID 304.

<sup>13/</sup> TR 490, FF 466.

<sup>14/</sup> FF 5, RX-113. We are convinced that complainant knew, or should have known, at the time that its complaint was filed that its models under two inches in diameter were not made in accordance with the '982 patent. Indeed, complainant has not argued that it believed its models with flow tubes less than two inches in diameter were made in accordance  
(Footnote continued on next page)

and inventory of its total MINI-MAG and K-MAG product lines. Thus, such data supplied by complainant was not specific to the domestic industry in this investigation. Respondents, however, supplied data specific to flowmeters within the specific size range of the domestic industry.

## 2. Effect to Substantially Injure

It is now well-settled that satisfaction of section 337's injury requirement does not automatically follow from proof of infringement of an intellectual property right. Corning Glass Works v. U.S. International Trade Commission, 799 F.2d 1559, 1566 (Fed. Cir. 1986) and Textron v. U.S. International Trade Commission, 753 F.2d 1019, 1028 (Fed. Cir. 1985). Thus, F&P must show more than infringement of its patent by respondents to establish injury in this investigation.

We recognize that the holder of an intellectual property right, who is entitled to exclude others entirely from using that right, is required to show a smaller quantum of proof of injury in order to prevail under section 337

---

(Footnote continued from previous page)

with the patent at the time that the complaint was filed. We note that Commission rules require complaints to be filed with domestic industry data broken out. Commission rule 210.20 (a)(8) states in pertinent part: Include a statement of facts indicating the effect or tendency to substantially injure. Such a statement would normally include the volume and trend of production, sales, and inventories of the involved domestic article; a description of the facilities and number and type of workers employed in the production of the involved domestic article; profit-and-loss information covering overall operations and operations concerning the involved domestic article; pricing information with respect to the involved domestic article; . . . . (Emphasis supplied.)

than would be required in a non-intellectual property-based case. Textron v. U.S. International Trade Commission, 753 F.2d 1019, 1029 (Fed. Cir. 1985); Bally/Midway v. U.S. International Trade Commission, 714 F.2d 1117, 1124 (Fed. Cir. 1983). The Court of Appeals for the Federal Circuit (CAFC) has declined to articulate the quantum of injury that is necessary to satisfy the injury requirement, holding that determination of injury is the type of question which the Commission is best suited to answer. Corning Glass Works, at 1568. Moreover, the CAFC has also held that the determination of injury necessarily must be based upon the particular facts of each case, and thus, is not controlled by Commission precedent. Corning Glass Works, at 1568.

Complainant F&P has a more difficult task in showing a causal connection between the infringing imports and injury than do complainants in some other investigations involving patent infringement because the relevant market contains non-infringing substitutes for the patented article. In addition to the patented article, the market contains non-infringing flanged and flangeless electromagnetic flowmeters, as well as other types of flowmeters which, depending on the particular application, can be substituted for electromagnetic flowmeters. <sup>15/</sup> Complainant thus cannot rely on the assumption that sales to Krohne would have gone to complainant in the absence of importation of the infringing flowmeters, or that any injury suffered by complainant is due to competition from respondent alone.

---

<sup>15/</sup> ID 84-85 and FF 499, FF 508, FF 520.

a. Constructed Domestic Industry Data <sup>16/</sup>

Complainant has maintained throughout the investigation that it does not keep its business records by size of model. Thus, nearly all <sup>17/</sup> of the economic data supplied by the complainant concerned total sales and production of the MINI-MAG and K-MAG in dollar amounts, regardless of whether the models were within the domestic industry size range. Complainant's sales manager gave an estimate of the percentage of the unit sales of the MINI-MAG model that were within the domestic industry. <sup>18/</sup> The sales manager was not able to estimate the percentage of K-MAGs that were within the domestic industry because F&P had been marketing the K-MAG for a relatively short time. <sup>19/</sup> In place of certain specific domestic industry data, the ALJ constructed domestic industry data by multiplying dollar figures given by F&P concerning its total MINI-MAG and K-MAG product line by the estimate of unit sales given by F&P's sales manager. Thus, the ALJ's findings concerning sales revenue, profitability, capacity, and inventory were based on (1) an assumption that the trends in the domestic industry and complainant's total MINI-MAG and K-MAG product-line were identical and (2) complainant's sales manager's estimate of the percentage of unit sales of the MINI-MAG that are within the domestic

---

<sup>16/</sup> Confidential Data is discussed in general terms where possible throughout this opinion.

<sup>17/</sup> Complainant supplied data specific to the domestic industry for lost sales and pricing. As discussed below, the pricing data was largely unusable.

<sup>18/</sup> TR 490.

<sup>19/</sup> The record shows that sales of the K-MAG constitute a small percentage of total MINI-MAG and K-MAG sales. FF 488.



industry size range. The ALJ justified his use of constructed data in the following manner:

While complainant has provided sales and profitability data with respect to MINI-MAG and K-MAG flowmeters, it has stated that it does not keep such data for flowmeters 2-4 inches in diameter. (FF 491). Given the common production facilities and employees used for the manufacture of flangeless magnetic flowmeters of all sizes by F&P, it is unlikely that profitability, employment and capacity data for the industry at issue could involve more than a simple allocation, and such an allocation would have no effect on trends. Nonetheless, complainant, through its business manager for flow products (FF 492), estimated that [ ] of its total sales were accounted for by the relevant flowmeters of 2-4 inches in diameter. (FF 492). Respondents' sales of flowmeters 2-4 inches in diameter accounted for between [ ] percent of their sales during 1983-1985. (FF 493). Furthermore, key data used by the Commission in assessing causation, such as lost sales and price competition, were available on the basis of relevant flowmeter sizes.

ID at 76, footnote 36.

We do not adopt the ALJ's use of constructed data. We find that the record does not support the assumption that trends in the domestic industry and F&P's entire product line are identical. Moreover, because F&P's estimate of sales of the patented product concerned unit sales, we find that F&P's estimate cannot be used to construct valid domestic industry data from total product line data provided by F&P in dollar amounts.

Complainant and the IA argued that a complainant should not be precluded from relief under section 337 merely because it does not maintain its records in the normal course of business in a manner that would enable it to provide precise domestic industry data. Complainant F&P and the IA contend that the evidence of record was reliable and probative and that the ALJ was entitled to rely upon it. Complainant argues that it had carried its burden of proof with respect to substantial injury and it was up to respondents to rebut that

proof. In this regard, complainant states that it had offered its invoices to respondents during discovery, and that respondents were free to use those invoices to rebut complainant's case.

By their arguments, the IA and complainant appear to seek to shift the burden of persuasion to respondents. Under the Administrative Procedure Act (APA), specifically 5 U.S.C. § 556(d), "the proponent of a rule or order has the burden of proof", except as otherwise provided by statute. Section 337 does not contain an exception to this APA provision. Thus, complainant F&P has the burden of proof on all issues on violation including "effect and tendency to substantially injure." Under 5 U.S.C. § 556(d), F&P must meet that burden by reliable, probative, and substantial evidence of record. Moreover, the Commission has stated on several occasions that complainant bears the burden of establishing injury and a nexus between the respondents' unfair acts and the injury to the domestic industry. See, Optical Waveguide Fibers, Inv. No. 337-TA-189, USITC Pub. 1754 (1985), at p. 10, aff'd. sub nom. Corning Glass Works, v. U.S.I.T.C., 799 F.2d 1559, (Fed. Cir. 1986); Drill Point Screws, Inv. No. 337-TA-116, USITC Pub. 1365 (1983) at pp. 16-17; Vertical Milling Machines, Inv. No. 337-TA-133, USITC Pub. 1512 (1984) at p. 42, aff'd. sub nom. Textron, Inc. v. U.S. International Trade Commission, 753 F.2d 1019 (Fed. Cir. 1985).

F&P contends that it should not be denied relief merely because it does not keep its business records by unit size. F&P, however, has not established that its position is any different from that of other complainants having a diverse product line, only part of which is covered by the U.S. patent in issue. It is complainant's burden to establish substantial injury under

section 337. That burden cannot be carried in this investigation with data that is not specific to the domestic industry. The fact that complainant does not maintain its business records segregated by size does not absolve complainant of its burden of proof in this investigation. <sup>20/</sup>

Finally, we construe complainant's statement that respondents could have used complainant's offered invoices to rebut complainant's case as an admission that complainant could have provided the data specific to the domestic industry if it had chosen to do so. Its failure to provide this data, thus, cannot be excused because of impossibility.

b. Market Share.

As the ALJ recognized, determining the market share of the accused flowmeter imports is complicated by the fact that the U.S. flowmeter market contains non-infringing substitutes for the patented article. <sup>21/</sup> The lack of specific data concerning the sizes of electromagnetic flowmeters produced by other suppliers in the market is an additional complication. <sup>22/</sup>

---

<sup>20/</sup> The Commission notes that complainant has expressed little interest in remedying the deficiencies of its domestic industry data. In the notice of review the Commission asked the parties to address the issue of whether a remand to the ALJ to take additional evidence would be helpful in concluding this investigation. 51 Fed. Reg. 33933, September 24, 1986. Complainant did not respond that such a remand would be helpful. Complainant reiterated in its brief on review that it does not keep its business records segregated by unit size and that it is not required to provide the Commission with such segregated data. Complainant's Review Brief at 12-14.

<sup>21/</sup> ID 84-85.

<sup>22/</sup> ID 86.

The ALJ's determination of market share was based, in part, on a U.S. market report, the Frost and Sullivan Report. <sup>23/</sup> This report, made available in 1984, provides market shares of the major producers in the U.S. electromagnetic flowmeter market for the year 1983. <sup>24/</sup> This report attributed a certain percentage of the market for electromagnetic flowmeters, both flanged and flangeless, to F&P. <sup>25/</sup> The report did not attribute a specific market share to Krohne. The ALJ constructed market share data for Krohne, in part, by attributing the percentage of market share found in the Frost and Sullivan Report to F&P for not only 1983, the year for which the market share estimate was made, but also for the years 1984 and 1985. The ALJ also relied upon Krohne's actual sales figures for the relevant market (2 to 4 inch flow tube diameter) and an estimate of F&P's sales in the relevant market. This estimate was made by multiplying F&P's total sales of MINI-MAG and K-MAG by F&P's estimate of its unit sales of flowmeters in the domestic industry as a share of total sales. <sup>26/</sup> We note that the ALJ's market share

---

<sup>23/</sup> CX-20. This confidential, proprietary report is marketed to interested members of the industry.

<sup>24/</sup> CX-20, Complainant's Review Brief at 3.

<sup>25/</sup> CX-20, Bates No. 00411.

<sup>26/</sup> The ALJ's calculation of market share, found in FF 498(c), can be explained as follows:

1. The ALJ made an assumption of complainant's actual market share for flangeless magnetic flowmeters in the 2-4 inch range for years including 1984 and 1985 based on the estimate taken from the Frost and Sullivan Report's of complainant's 1983 market share for flanged

(Footnote continued on next page)

calculation, based as it was on the assumption that complainant's market share remained constant, did not show a market shift away from the complainant.

The Commission finds that the ALJ's calculation of Krohne's market share was without sufficient basis in the record. Although the data contained in the Frost and Sullivan Report may have been accurate for 1983, the record does not establish that the same data were also accurate for the years 1984 and 1985. We note that the '82 patent issued on December 20, 1983, and thus its impact on the market is not reflected in the 1983 industry data. We also find that there is insufficient basis in the record for the ALJ to use complainant's estimate of unit sales within the relevant size range to construct market share data for the entire industry. The only support for this assumption in the record is the finding that a certain percentage of

---

(Footnote continued from previous page)

as well as flangeless magnetic flowmeters in all sizes.

2. The ALJ constructed figures for complainant's unit sales of flangeless magnetic flowmeters in the relevant size range for the years 1982-1985 by multiplying complainant's total sales by the estimate of percentage of unit sales made by complainant's sales manager.

3. The ALJ used the assumed market share and the constructed sales figures to calculate the size of the entire flangeless market in the 2-4 inch range. For example, in 1985, if the percentage of this market belonging to complainant totalled 1,952 unit sales (the complainant's total sales multiplied by complainant's estimate of percentage of sales in the relevant market), the ALJ extrapolated that 100 percent of this market would total 7,230 unit sales.

4. Finally, the ALJ divided respondents' actual unit sales in the relevant market by his calculation of total sales in the market in order to determine respondent's market share.

Krohne's sales are in the relevant market, <sup>27/</sup> a percentage which in our view is only marginally comparable.

c. Sales and Profitability.

The ALJ found that the domestic industry experienced a decline in sales revenue and profits in 1985. This finding, however, was based on figures relating to F&P's flangeless flowmeters up to 4 inches in diameter, which includes flowmeters outside the domestic industry, viz., flowmeters less than 2 inches in diameter. <sup>28/</sup>

Because complainant F&P did not furnish sales revenue and profit data for the domestic industry as the domestic industry is defined in this investigation, valid conclusions about sales and profits in the domestic industry cannot be derived from the evidence of record. The ALJ's conclusions are based on an assumption that the sales and profits of the domestic industry follow the same trends as F&P's entire product line of flangeless electromagnetic flowmeters. There is nothing in the record to support the ALJ's assumption, and we cannot find that domestic industry sales and profits have declined based on the evidence of record.

d. Domestic Industry's Capacity and Inventory

The ALJ found that substantial excess capacity existed in the domestic industry. He based this finding on F&P's estimate of its production capacity

---

<sup>27/</sup> FF 493.

<sup>28/</sup> ID at 85, FN 47.

for MINI-MAG flowmeters 1985, operating one shift, and its actual production of MINI-MAG and K-MAG units in 1985. <sup>29/</sup> Referring to his findings on domestic industry capacity, the ALJ specifically held that F&P could meet domestic requirements. <sup>30/</sup> We note that the ALJ did not specifically address the production capacity of the K-MAG in his analysis. However, the ALJ made several findings of fact <sup>31/</sup> concerning F&P's supply of imported ceramic flow tubes that form an essential part of the K-MAG. We determine that these findings together with the production capacity findings for the MINI-MAG can support a finding that the domestic industry has excess capacity. The excess domestic capacity, however, far exceeds the shipments of infringing imports. <sup>32/</sup> Therefore, factors other than infringing imports are responsible for the under utilization of domestic industry capacity. We determine that in view of the total record, the finding of excess domestic capacity alone cannot support a determination of substantial injury.

The ALJ found that F&P's year-end inventory of MINI-MAG and K-MAG flowmeters (parts and finished goods) increased from 1984 to in 1985. <sup>33/</sup> This finding, however, was based on data which includes inventories of flowmeters outside of the domestic industry. We determine that a finding concerning domestic industry inventory cannot be based on the data of record.

---

<sup>29/</sup> ID 86.

<sup>30/</sup> ID 97.

<sup>31/</sup> FF 544 - FF 561.

<sup>32/</sup> Compare FF 497 with FF 442.

<sup>33/</sup> ID 86.

e. Price Competition

Because the price comparisons submitted by the parties were not legitimate for various reasons, the ALJ performed his own price analysis. <sup>34/</sup> The ALJ sought to compare prices of the F&P K-MAG and the Krohne ALTO-FLUX because both of these models have ceramic spools and are comparable in accuracy. The ALJ did not find a pattern of underselling, but found instead "price competition." <sup>35/</sup> The ALJ found one instance where Krohne had priced its product lower than F&P and one instance where F&P had priced its product lower than Krohne. <sup>36/</sup> In addition, the ALJ found that Krohne and a customer had entered into an OEM agreement in 1983 that was renewable yearly. The ALJ found that this customer accepts bids from both Krohne and F&P and that Krohne made its sales to this customer because of lower prices. <sup>37/</sup>

Past Commission practice has been to consider underpricing as a factor in analyzing substantial injury by imports. See, e.g., Drill Point Screws for Drywall Construction, Inv. 337-TA-116, USITC Pub. 1365 (1983); Vertical Milling Machines, Inv. 337-TA-133, USITC Pub. 1512 (1984); and Optical

---

<sup>34/</sup> ID 93, FN 50. Both F&P and Krohne have list prices, but because of heavy discounting, list price comparisons reveal little about actual price competition. See FF 656, FF 660-663, FF 665-667, FF 672.

<sup>35/</sup> ID 94.

<sup>36/</sup> ID 94.

<sup>37/</sup> ID 94.



Waveguide Fibers, Inv. No. 337-TA-189, USITC Pub. 1754 (1985). The ALJ did not find clear evidence of underpricing in this investigation. He found only three comparable sales, and determined that there was underselling in only two of those sales. The ALJ characterized Krohne's pricing practices as price competition. Since price competition occurs anytime there are at least two suppliers in the marketplace, we decline to consider "price competition" as a factor to be weighed heavily in determining whether substantial injury has been caused by imports. Based on the data of record, the Commission finds no pattern of underselling by Krohne in this investigation.

f. Lost Sales

The ALJ found that in order to establish causation complainant must show that: "(1) it lost sales to respondents rather than to non-infringing competition; and (2) respondents' sales were at the expense of complainant, not at the expense of the non-infringing competition."<sup>38/</sup> In the context of the ALJ's entire lost sales analysis, we interpret the first criterion to be that the sales in question must have been made by respondents, not by a non-infringing competitor.

The ALJ found that in order to meet the second criterion complainant must show that it sold or offered to sell a comparable patented product during a comparable period to a customer who purchased the Krohne product or that the purchaser considered complainant's product to be an alternative to Krohne's

---

<sup>38/</sup> ID 88.

product. Relying on Convertible Rowing Exercisers, Inv. No. 337-TA-212 (1985) (unreviewed initial determination), the ALJ held that complainant need not show that sales made by Krohne would definitely have gone to F&P. <sup>39/</sup>

The ALJ found that complainant F&P had met the criteria for lost sales with respect to four customers. <sup>40/</sup> The ALJ calculated these lost sales as a percentage of Krohne's and F&P's total sales <sup>41/</sup> The calculated percentage was quite small in 1985 and slightly under half that amount in 1984. <sup>42/</sup>

We determine that Krohne's sales to two customers <sup>43/</sup> and Krohne's sales to one customer after the introduction of the K-MAG in 1985 <sup>44/</sup> qualify as lost sales. We find, however, that the sales to one customer <sup>45/</sup> prior to F&P's introduction of the K-MAG which is equipped with a ceramic flow tube in early 1985, and the sales to another customer <sup>46/</sup> do not qualify as lost sales as found by the ALJ.

---

<sup>39/</sup> ID 88.

<sup>40/</sup> ID 87-91.

<sup>41/</sup> F&P's sales data was constructed by multiplying total sales revenues by the estimate of unit sales made by complainant's sales manager.

<sup>42/</sup> ID 92-93.

<sup>43/</sup> FF 595-604 and FF 605-613.

<sup>44/</sup> FF 568(a).

<sup>45/</sup> FF 564-569.

<sup>46/</sup> FF 581-583.

The ALJ found that one customer <sup>47/</sup> was concerned with how well a flowmeter could withstand abrasive coal slurries when evaluating flowmeters at a pilot plant in 1983. Prior to purchasing Krohne electromagnetic flowmeters in 1983, this customer was using F&P non-ceramic electromagnetic flowmeters as well as other models. <sup>48/</sup> The ALJ found that the Krohne meters were not purchased as direct replacements for existing flowmeters, but for use in the coal slurry application. He also found that this customer had concluded that ceramic flow tubes were superior to non-ceramic flow tubes for this application and bought Krohne flowmeters without opening the purchase to bids. <sup>49/</sup>

We believe that the sales to this customer prior to F&P's introduction of the K-MAG, in early 1985 do not qualify as lost sales. There is evidence in the record that teflon-lined flow tubes are not suitable for abrasive slurries. <sup>50/</sup> The ALJ did not discuss this evidence. Moreover, the ALJ attributed no significance to the fact that the customer had concluded that ceramic flow tubes were superior for the coal slurry applications, and thus, purchased flowmeters from Krohne without opening the bidding to others. We believe, however, that Krohne's sales to this customer after the introduction of the K-MAG in early 1985 qualify as lost sales as found by the ALJ.

---

<sup>47/</sup> FF 566.

<sup>48/</sup> ID 89.

<sup>49/</sup> ID 89.

<sup>50/</sup> FF 451, FF 501.

Although the ALJ found that Krohne's sales to one customer <sup>51/</sup> qualified as lost sales to F&P, the ALJ acknowledged in his findings that a non-infringing competitor was the next lowest bidder to Krohne in the sale to this customer. <sup>52/</sup> The ALJ did not mention the non-infringer's lower bid in his analysis, nor did he discuss earlier, unsatisfactory dealings that F&P had had with this customer. While anecdotal instances of customer dissatisfaction may not be sufficient to disprove a causal nexus between imports and injury, we believe that they are probative with respect to the decision of a single purchaser to avoid a specific supplier. Moreover, there is no evidence in the record to support F&P's assertion that the non-infringer's flanged meters were not suitable for this customer's needs. After deducting the sales that we find do not qualify as lost sales, we find that sales lost to Krohne by F&P to be approximately 65 percent of the amount calculated by the ALJ for 1984 and 80 percent of the amount that the ALJ calculated for 1985.

The Commission determined in Optical Waveguide Fibers, Inv. No. 337-TA-189, USITC Pub. 1754 (1985) at 13, aff'd sub nom. Corning Glass v. U.S.I.T.C., 799 F.2d 1559, (Fed. Cir. 1986) that "the mere existence or threat of some lost sales is not necessarily sufficient for what is required is a 'significant share' of the market, or a 'significant amount' of such sales . . . ." Given that there is not sufficient evidence in the record to compute lost sales as a percentage of total sales, it is not possible to determine whether the sales lost by F&P to Krohne are significant.

---

<sup>51/</sup> ID 90-91.

<sup>52/</sup> FF 581.

In summary, we find that the complainant has not carried its burden of proof to establish that the domestic industry has suffered substantial injury by reason of Krohne's infringing imports. Because of the presence of non-infringing substitutes in the marketplace, complainant cannot rely on the assumption that any injury it has suffered is due to respondents' unfair act.

Complainant has not provided the Commission with specific domestic industry data, despite the fact that such data is within its control, and complainant does not explain why presenting the data in usable form to the Commission would impose any more of a hardship on it than it would on any complainant with a diverse product line. In addition, no shift of market share from complainant has been established in this investigation. Respondents were not found to be underselling. There were few lost sales established, and it is impossible to determine from the record whether those sales are significant. While excess domestic capacity has been established, that finding alone cannot support a determination of substantial injury.

### 3. Tendency to Substantially Injure

In Corning Glass Works, the U.S. Court of Appeals for the Federal Circuit (CAFC) held that "where the asserted injury is based on projections of future injury, i.e., on a 'tendency to substantially injure', the record must establish the existence of relevant conditions or circumstances from which probable future substantial injury can reasonably be inferred." Corning Glass Works at 1567-68. The CAFC specifically declined to enunciate a legal standard with respect to the threshold of injury required to establish a "tendency" to substantially injure, but rejected the standard that unfair

methods or acts that result in even "conceivable losses of sales " establish injury to the domestic industry. Corning Glass Works, at 1568.

Following the guidelines set forth in Methods for Extruding Plastic Tubing, Inv. No. 337-TA-110, 218 U.S.P.Q. 348 (1982), and Reclosable Plastic Bags, Inv. No. 337-TA-22, 192 U.S.P.Q. 674 (1977), the ALJ considered foreign cost advantage and production capacity, ability of the imported product to undersell complainant's product, and the potential and intent to penetrate the U.S. market in finding a tendency to injure. <sup>53/</sup>

The ALJ found that cost of production requirements are not helpful in this investigation because F&P's and Krohne's cost data are on different bases, with F&P's basis including the cost of an electronic converter and Krohne's basis excluding it. <sup>54/</sup> We adopt this finding.

The ALJ's finding of excess foreign capacity is apparently based on the fact that Krohne does not allocate its orders on a per country basis, but rather fills orders on a first-come, first-served basis. Thus, the ALJ rejected Krohne's argument that it serves a world-wide market and only a fixed percentage of its capacity is available to the United States, and made a finding that excess foreign capacity exists. <sup>55/</sup> We do not find, however, that the record as a whole supports the ALJ's finding of excess foreign capacity. We note that there is no evidence of record that foreign markets

---

<sup>53/</sup> ID 95.

<sup>54/</sup> ID 97.

<sup>55/</sup> ID 98.

are saturated or that the U.S. market is being targeted. Thus, it would be speculation to find that merely because Krohne fills orders on a first-come, first-served basis, more foreign capacity is available for shipments to U.S. markets.

The ALJ found that profit margins at both Krohne-Germany and Krohne-America <sup>56/</sup> show that

[ ] <sup>57/</sup> However, given that Krohne-America's net profit margin [ ], we do not believe that [ ] are likely.

The ALJ found that Krohne has the capability to continue making sales in the U.S. market. Krohne has a network of independent sales representatives in the United States, and Krohne-America has

[ ]. <sup>58/</sup> The ALJ based his finding of a tendency to injure, in part, on Krohne's intention to remain in the U.S. market. In making this determination, the ALJ did not find that Krohne had the intention of increasing shipments to the United States, but found instead that the record indicates that Krohne has demonstrated the ability to compete effectively in the United States market. <sup>59/</sup>

The ALJ acknowledged that Krohne-America's shipment levels [had declined] in the first quarter of 1986, relative to the same period of 1985, but he

---

<sup>56/</sup> FF 682-683 and FF 562. The Krohne-Germany profit margin referred to by the ALJ concerns gross profits. The record does not contain any information on Krohne-Germany's net profits.

<sup>57/</sup> ID 97.

<sup>58/</sup> ID 99. FF 690, FF 442, FF 689, FF 691.

<sup>59/</sup> ID 99.

determined that in light of a [ ] from Krohne-Germany during 1983-1985 and Krohne-America's inventory level, use of the 1986 shipment levels to project future trends was unreliable. <sup>60/</sup> We determine, based on the evidence of record, that Krohne-America's shipments of infringing flowmeters have been [ ]. <sup>61/</sup> While total shipments from Krohne-Germany [ ], this data is not specific to Krohne's infringing products. <sup>62/</sup>

In assessing tendency to substantially injure, the Commission focuses on the potential and the intent to penetrate the U.S. market. See, e.g., Methods for Extruding Plastic Tubing and Reclosable Plastic Bags, *supra*. In this investigation, the ALJ based his finding of a tendency to substantially injure on Krohne's intent to remain a factor in the U.S. market. The Commission has determined that the record does not support a determination of substantial injury. We decline, therefore, to find that respondents' intent to remain in the market can support a determination of a tendency to substantially injure in this investigation. Such a determination would be contrary to the Commission's holding in Optical Waveguide Fibers, *aff'd sub nom. Corning Glass Works v. U.S.I.T.C.*, 799 F.2d 1559 (Fed. Cir. 1986). In that investigation, the respondents were importing a small amount of optical fiber,

---

<sup>60/</sup> ID 99.

<sup>61/</sup> Krohne-America's shipments of infringing units were found to total [ ] in 1982, [ ] in 1983, [ ] in 1984, [ ] in 1985, and [ ] for the first quarter of 1986. FF 444.

<sup>62/</sup> FF 442



insufficient to cause substantial injury, and intended to continue to import small amounts. The Commission declined to find a tendency to substantially injure in that investigation because the record showed that imports had had no substantial adverse effects on the domestic industry, and the complainant had not demonstrated that the situation would be otherwise in the future. Optical Waveguide Fibers at 19.

In summary, we determine that complainant has not shown that relevant conditions or circumstances exist to establish a tendency to substantially injure as required by Corning Glass Works. Complainant has not proven that it has been substantially injured by respondents' present level of importation and sales, and the evidence of record does not indicate that respondents' present activities are likely to change in any way that would tend to cause substantial injury in the future. Sales of infringing flowmeters [ ] since 1984. Krohne-America's profit margin [ ], and thus [ ] in Krohne's prices are unlikely. Krohne-Germany serves a world-wide market, and there is no evidence of record that the foreign markets are saturated. Moreover, there is no evidence of record indicating that Krohne intends to target or expand in the U.S. market. Finally, the record does not demonstrate a market shift away from complainant.

#### 4. Conclusion

Based on the foregoing, we determine that neither an effect nor tendency to substantially injure the domestic industry by reason of infringing imports has been established in this investigation. We therefore determine that there has been no violation of section 337 in this investigation.

Certificate of Service

I, Kenneth R. Mason, hereby certify that the attached COMMISSION MEMORANDUM OPINION, was served upon Juan Cockburn, Esq., and Gary Rinkerman, Esq., and upon the following parties via first class mail and air mail, on November 18, 1986.

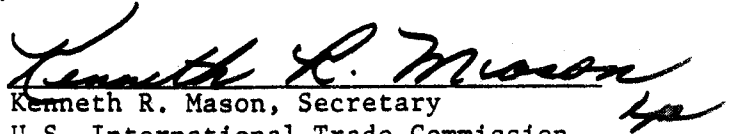
  
Kenneth R. Mason, Secretary  
U.S. International Trade Commission  
701 E Street, N.W.  
Washington, D.C. 20436

For Complainant Fischer and Porter Company:

John M. Calimafde, Esq.  
Hopgood, Calimafde, Kalil,  
Blaustein and Judlowe  
Lincoln Building  
60 East 42nd Street  
New York, New York 10165

For Respondents Krohne-America, Inc. and  
Krohne Messtechnik GmbH and Company KG:

Tom M. Schaumberg, Esq.  
Plaia and Schaumberg  
1019 19th Street, N.W., PH-II  
Washington, D.C. 20036

Robert A. Cesari, Esq.  
Cesari and McKenna  
Union Wharf East  
Boston, Massachusetts 02109

VIEWS OF CHAIRMAN LIEBELER AND VICE CHAIRMAN BRUNSDALE

Certain Unitary Electromagnetic Flowmeters

337-TA-230

The majority in this case has reversed an affirmative determination of the administrative law judge (ALJ) on the grounds that the unfair act has not had the effect or tendency to cause substantial injury to the domestic industry.<sup>1</sup> In contrast, we would modify and affirm the ALJ's decision.

---

1

Because we have not seen the majority opinion, our references to the majority's views are, at best, educated guesses. It is very difficult to write a dissenting opinion without seeing the majority opinion. Unfortunately, Commission practice of the last several years has been not to circulate opinions. Although we provided copies of a draft of this opinion to the majority to enable it to respond to our analysis, the majority declined to share their opinion with us. Courts and other agencies have found that the sharing of opinions produces better opinions. In our view, the lack of opinion-sharing at the Commission leads to inadequate, if any, joining of issues. The parties, the public, and the reputation of the Commission all suffer as a result.

RECEIVED  
UNITARY  
P12: 28

100

I. Introduction

Section 337(a) of the Tariff Act of 1930, as amended, provides that unfair methods of competition and unfair acts in the importation of articles into the United States are unlawful if "the effect or tendency of the acts is to destroy or substantially injure an industry, efficiently and economically operated, in the United States . . . ."<sup>2</sup> Complainant, Fischer & Porter Company (F&P), proved the existence of the unfair act to the satisfaction of the ALJ and all the Commissioners by showing that respondents<sup>3</sup> imported and sold certain unitary electromagnetic flowmeters<sup>4</sup> that directly infringed U.S. Letters Patent 4,420,982 (the '982 patent)<sup>5</sup> owned by complainant. Complainant also succeeded in

---

<sup>2</sup> 19 U.S.C. { 1337(a) (1982) (emphasis added).

<sup>3</sup> Respondents are Krohne Messtechnik GmbH & Company KG and Krohne-America, Inc. Finding of Fact by the ALJ ("FF") 9.

<sup>4</sup> "Electromagnetic flowmeters are especially adapted to measure the volumetric flow rates of fluids which present difficult handling problems, such as corrosive acids, sewage and slurries." Initial Determination (hereinafter referred to as "ID") at 6.

<sup>5</sup> The '982 patent, titled "Unitary Electromagnetic Flowmeter With Sealed Coils," was issued on December (Footnote continued to page 3)

convincing the ALJ and the Commission of the existence of a domestic industry that produces flangeless electromagnetic flowmeters made in accordance with the '982 patent.<sup>6</sup> Thus, our only disagreement with the majority concerns whether the effect or tendency of the unfair act is to cause substantial injury to the domestic industry.

## II. The Determination of the ALJ

Complainant's business manager, Thomas Dimm, testified, and the ALJ found, that complainant did not maintain sales data for its flowmeters by unit size.<sup>7</sup> Mr. Dimm testified that overall sales were down<sup>8</sup> and

---

(Footnote continued from page 2)  
20, 1983. The patent has been assigned to F&P. ID at 5.

<sup>6</sup>  
Both complainant and respondents produce flowmeters of varying sizes. Complainant stipulated that only its MINI-MAG and K-MAG flowmeters between two and four inches in diameter were made in accordance with the patent. ID at 76. The ALJ found that only those imports of respondents measuring two inches or more in diameter infringe the patent. ID at 50-51.

<sup>7</sup>  
FF 491.

<sup>8</sup>  
FF 490.

that [ ] percent of complainant's total sales were  
accounted for by flowmeters made under the patent.<sup>9</sup>

One of the key determinants in establishing that an unfair act has caused substantial injury to a domestic industry is the market share held by the infringing imports.<sup>10</sup> Complainant urged the ALJ to make a simple market share calculation where the market would be defined as the aggregate sales of complainant and respondents of magnetic flowmeters between two and four inches in diameter. Using this method, import market share is over  
<sup>11</sup>  
[ ] percent.

The ALJ rejected such a straightforward calculation because he found that "non-infringing competition also exists, and should be thus part of the 'market'.

---

<sup>9</sup> FF 492. The ALJ found "[t]he business manager has responsibility for the sale of all flow products including MINI-MAG and K-MAG flowmeters and is thoroughly familiar with F&P financial data such as profits and sales." Id.

<sup>10</sup> See note 27 and accompanying text, infra.

<sup>11</sup> This market definition was also urged by the attorney from the Commission's Office of Unfair Imports Investigation. ID at 86 n.48.

Therefore, an estimate of sales of competitive non-infringing magnetic flowmeters should also be included when estimating Krohne's market share."<sup>12</sup> Since no data existed on the two-to-four inch electromagnetic flowmeter market, the ALJ chose to extrapolate based on a market study of the flange and flangeless electromagnetic flowmeter industry.

This study, the Frost and Sullivan Report,<sup>13</sup> estimated that complainant's share of the overall magnetic flowmeter market was [ ] to [ ] percent in 1983.<sup>14</sup> The ALJ assumed that this would hold true for the two-to-four inch flangeless market as well and that this percentage continued in 1984 and 1985.<sup>15</sup> He therefore took [ ] percent of complainant's total sales and divided by [ ] to get the total sales for two-to-four inch flangeless

---

12  
ID at 86 n.48.

13  
See FF at 498(a)-(d).

14  
The report was admitted into evidence in part because respondents, as well as complainant, relied on the information contained therein. ID at 86-87; FF 498(b).

15  
FF 498(c).

16  
electromagnetic flowmeters. The ALJ then divided  
respondents' sales of these flowmeters by this total to  
obtain the market share of the infringing imports. Using  
this method, the ALJ concluded that respondents' market  
share increased from [ ] percent in 1982 to [ ]  
percent in 1983 and [ ] percent in 1984 before  
[declining to ] percent in 1985.<sup>17</sup>

The ALJ next discussed at length sales allegedly lost  
by complainant to respondents' infringing imports.  
Complainant claimed that, after certain adjustments,  
respondents captured approximately [\$ ] worth of  
sales of flowmeters two inches and over to common  
customers during 1984-85.<sup>18</sup>

The ALJ determined that because non-infringing  
competition was present, it could not be assumed that all

---

16

For example, total complainant's sales for all  
sizes multiplied by [ = ] flangeless  
two-to-four inches in diameter magnetic flowmeters sold  
in 1984. Thus, total market sales for the two-to-four  
inches in diameter magnetic flowmeters equaled  
[( divided by )].

17

FF 498.

18

ID at 88.



of respondents' sales would have been captured by complainant. On this basis, the ALJ reduced the amount of sales lost by complainant to approximately [\$ ] during 1984-85.<sup>19</sup> In 1984 this represented [ ] percent of aggregate sales of complainant and respondents for flowmeters two-to-four inches in diameter, and [ ] percent in 1985.<sup>20</sup> The ALJ concluded that the lost market share was significant.<sup>21</sup>

In addition, the ALJ found that the domestic industry was operating well below capacity, inventories were increasing, and price competition existed between the

---

19

ID at 92. The ALJ found that causation would be shown if (1) complainant lost sales to respondents rather than to non-infringing competition, and (2) respondents' sales were at the expense of complainant, not at the expense of the non-infringing competition. ID at 88. The first criterion was satisfied when respondents made a sale to one of complainant's customers. The second criterion was met when complainant offered to sell a comparable patented product during a comparable period to a purchaser of respondents' product or when the purchaser considered complainant's product to be an alternative to respondents product. The ALJ found that only about 15 percent of \$[ ] of sales [(\$ )] of infringing goods by respondents constituted "lost sales."

20

ID at 92.

21

ID at 94.

products. Therefore, after a review of the record, he concluded that "complainant has met its burden of proof by a preponderance of evidence that the domestic industry has been substantially injured by the respondents' activities in the United States."<sup>22</sup>

Finally, the ALJ found that respondents have demonstrated "the ability to compete effectively in the United States, and the intention to remain a factor in the United States market."<sup>23</sup> He therefore also determined that respondents' imports had a tendency to substantially injure the domestic industry.

### III. Opinion

The decision in this case follows closely on the heels of Corning Glass Works v. USITC, in which the Court of Appeals for the Federal Circuit affirmed the

---

22

ID at 94.

23

ID at 98. The ability to compete was based on the level of sales by respondents. The finding of the intent to remain in the U.S. was based on sales trends over the past few years, in addition to the presence of [ ] sales representatives for respondents. FF 690.

Commission's determination in Certain Optical Waveguide  
<sup>24</sup>  
Fibers. In Optical Waveguide Fibers, the Commission  
found that imports of products infringing a U.S. patent  
did not have an effect or tendency to substantially injure  
the domestic industry producing optical waveguide fibers  
because infringing imports were de minimus.

In affirming the Commission's determination, the  
court rejected appellant's argument that earlier precedent  
stood for the proposition that "unfair methods or acts  
that result in even 'conceivable losses of sales'  
establish injury to the domestic industry."<sup>25</sup> The court  
stated that appellant's "proposed 'test' for injury may be  
easily rejected as statutorily impermissible . . . ."<sup>26</sup>  
Thus, it has been firmly established that something more  
than a de minimus level of sales of infringing product is  
required to satisfy the statutory injury test.

---

<sup>24</sup>  
Corning Glass Works v. USITC, 799 F.2d 1559 (Fed.  
Cir. Aug. 27, 1986), aff'ing Certain Optical Waveguide  
Fibers, Inv. No. 337-TA-189, USITC Pub. 1754 (1985).

<sup>25</sup>  
799 F.2d at 1568.

<sup>26</sup>  
Id.

The Corning Glass Works court, however, did not enunciate what exactly this "something more" is. The court stated:

[I]t would be difficult to articulate positively what quantum of injury is legally required. Indeed, the question of quantum of injury is not one on which it would be appropriate for this court to put forth a legal standard. The statement in Textron that "the infringer holds, or threatens to hold, a significant share of the domestic market in the covered articles or has made a significant amount of sales of the articles" gives guidance, but it is not definitive of the considerations relevant to the injury

27

inquiry.

The majority's search for other "relevant" considerations has led it to increase the burden on complainants in intellectual property cases beyond that contemplated by

28

statute.

---

27

Id. (quoting Textron, Inc. v. USITC, 753 F.2d 1019, 1029 (Fed. Cir. 1985)).

28

The standard of review for Commission section 337 injury determinations is a low one. The court in Corning Glass Works noted:

In any event, determination of injury is precisely the type of question for which the Commission has the expertise and has been given the responsibility to answer. Moreover, the

(Footnote continued to page 11)

The instant investigation presents a clear example of overburdening the complainant by requiring additional proof. As noted earlier complainant, responding to the "guidance" provided in Textron, presented evidence demonstrating that respondents had sold a large amount of infringing imports and that respondents held a large share of the domestic market.<sup>29</sup> It should be noted that the guidance in Textron was given in the disjunctive: significant level of sales or significant market share. The ALJ found convincing evidence on both.

Respondents' sales of infringing flowmeters during

---

(Footnote continued from page 10)

determination of injury necessarily must be based upon the particular facts of each case. In view of these considerations, the appropriate function of this court is to review an injury determination to decide whether substantial evidence supports the facts relied on and whether the Commissioner's [sic] determination, on the record, is arbitrary, capricious, or an abuse of discretion.

799 F.2d at 1568 (citations omitted). Nonetheless, in certain circumstances, the Federal Circuit will reverse. See Bally/Midway Mfg. Co. v. USITC, 219 USPQ 97 (Fed. Cir. 1983), reversing In re Certain Coin-Operated Audiovisual Games and Components Thereof, Inv. No. 337-TA-105, 218 USPQ 924 (USITC 1982).

29

See text accompanying note 27 supra.

1984-85 were valued at over [\$<sup>30</sup> ] and  
additional sales occurred in the first quarter of  
1986.<sup>31</sup> It is clear from Corning Glass Works that the  
Commission must look beyond the volume of respondents'  
sales.<sup>32</sup> Comparing respondents' sales to complainant's  
sales shows that [\$ ] represents a substantial  
loss of sales revenue and associated profit for  
complainant.<sup>33</sup> Had complainant made these sales, its  
sales revenue would have increased more than 7 percent  
during this period.<sup>34</sup> This magnitude of sales is  
clearly significant.

Much of the argument by complainant, respondents, and  
presumably the majority focuses on what fraction of the  
infringing sales constitutes "lost

---

<sup>30</sup>  
FF 562 (based on respondents' exhibit).

<sup>31</sup>  
FF 563.

<sup>32</sup>  
The Corning Glass Works court held that "whether  
the amount is 'significant cannot be determined by the  
dollar amount in vacuo." 799 F.2d at 1559.

<sup>33</sup>  
FF 490.

<sup>34</sup>  
The actual increase in sales revenue would depend  
on the sensitivity of demand to changes in price  
(demand elasticity) for flowmeters.

sales." Complainant argued that respondents' sales to customers common to complainant and respondents totaled [\$           ]. The ALJ's finding with respect to lost sales was that complainant's actual losses to respondents totaled only [\$           ].

It is our understanding that the majority concluded that the value of the lost sales was even lower. Among the reasons probably given were that some of respondents' sales consisted of products that improved on the patent, and that other sales would not have gone to complainant because of lower bids by producers of non-infringing flowmeters.

Arguing over whether sales by respondents would have gone to complainant's legitimate competitors is a case of Monday morning quarterbacking. For example, the ALJ found that "[b]ased on the fact that Krohne and F&P competed directly for sales to [       ], sales by Krohne to [       ] could

---

35

See notes 18-21 and accompanying text for a discussion of the ALJ's analysis.

36

See note 1 supra.

37

have gone to F&P." This is a reasonable conclusion. To conclude otherwise that a competitor with a different product (for example, one not produced under the claims of the patent) would have won the contract simply because of a lower bid is to assume that the products are identical in every respect except for price. Clearly, if the competing product is not produced under the patent, it cannot be identical to the patented product. Price differentials are to be expected with differentiated products. The lower priced product is usually lower priced for a reason (lower quality, less valuable warranties, slower delivery, etc.). Although it is possible that the competing product would be selected in the absence of the infringing product, the choice of the infringing product is some evidence that the purchaser preferred the patented features. It cannot be known

---

37  
ID at 91.

38  
The ALJ found that the flangeless construction claimed in the '982 patent contributed to the compact size of the flowmeters and had a "profound effect on increasing market penetration." He also found that respondents had discussed marketing such a product as early as 1965. ID at 84; FF 533(a).

A corollary to this argument is that sales of higher priced infringing products can, and do, cause  
(Footnote continued to page 15)



who would have captured these sales. Moreover, because respondents are not entitled to any sales of products that infringe complainant's patent or that improve on that patent,<sup>39</sup> requiring evidence that complainant would have made a given sale is unnecessary in a section 337 case.

The above argument illustrates part of the problem and the unnecessary effort involved in trying to assess which sales were "lost" by complainant. In cases involving intellectual property rights, everyone agrees that the owner of the right is entitled to all sales of products covered by the patent. The simplest and most

---

(Footnote continued from page 14)  
injury to the domestic industry. If the infringing flowmeter lasts twice as long as the legitimate product, purchasers might be willing to pay twice as much for it. If there were no infringing product, however, the purchaser might buy two legitimate products. This example is one of an infinite number of circumstances in which one would expect the domestic producer to be harmed by a higher priced infringing import. The majority may have determined that the absence of "underpricing" is relevant to the Commission's determination. See note 1 supra.

39

Corning Glass Works, 799 F.2d at 1567 ("Corning cannot be faulted in its analysis that a patentee is entitled to benefit from all sales in the United States covered by its patent and that diversion of any sales by an infringer without payment of royalties is legally and in fact an economic loss to the patentee").

legitimate measure of the harm is total sales of the infringing good.

The Federal Circuit has not instructed the Commission to look beyond this statistic and develop counterfactual inquiries. According to the court in Textron, "the domestic industry must normally establish that the infringer holds, or threatens to hold, a significant share of the domestic market in the covered articles or has made a significant amount of sales of the articles."<sup>40</sup>

Instead of determining when a sale of an infringing good is "lost" by complainant, what the Commission should do is to determine when the level of sales is significant for a particular industry. In Corning Glass Works the court stated:

Corning asserts that Sumitomo's past sales have caused substantial injury because the amount of Sumitomo's sales has totaled several million dollars. Corning asserts that this amount ipso facto meets the "test" of Textron that an injury is shown where sales are of a "significant amount." As indicated above, the amount of sales is highly

---

40

753 F.2d at 1029; accord, Corning Glass Works, 799 F.2d at 1568.

relevant to the injury determination; however, whether the amount is "significant" cannot be determined by the dollar amount in vacuo. "Significant" requires some further inquiry once the amount of sales is found. Corning's comparison of the dollar amount of Sumitomo's sales to Spectran's investment in its plant and to ITT's profit figures is unpersuasive as a basis for deciding whether the amount of the infringing sales is "significant." Conversely, the ALJ's comparison of Sumitomo's sales with the total sales of fiber in the U.S. market, as well as with the volume of sales of Corning and its domestic licensees, is meaningful and the conclusion that Sumitomo's sales were de minimus in those contexts is rational. Thus, there is no basis for holding that this part of the Commission's decision

41

is arbitrary or capricious.

The significance of respondents' sales was discussed

---

41

799 F.2d at 1569.

In Corning Glass Works the court does discuss certain findings by the ALJ relating to "lost sales." Id. The court seems to accept the proposition that sales were not lost where "Corning and its licensees could not satisfy demand for the product, despite increasing their capacities, that they had put customers on allocation; and, indeed, that they were themselves importing fiber in order to fill orders." Id.

It is unclear whether the court actually accepted this argument ("Thus, the evidence, per the ALJ, did not establish a nexus between Sumitomo's sales and any past injury to the domestic industry." Id. at 20 (emphasis added)). This issue need not be addressed because this case is distinguishable. The ALJ in this case clearly found that complainant is not operating at full capacity whereas in Corning Glass Works the complainant was operating at full capacity. Id. at 86.

42  
above. As for market share, the ALJ presented several indicators. The first measured respondents' infringing sales as a share of total market sales of flangeless electromagnetic flowmeters sized two-to-four inches in diameter.<sup>43</sup> This produced a market share for respondents of [ ] percent in 1984 and [ ] percent in 1985.<sup>44</sup> The second measured complainant's "lost sales" as a share of respondents' and complainant's combined sales of these two-to-four inch meters. Under this method, respondents' share was between [ ] and [ ] percent in 1984-85.<sup>45</sup>

The final indicator measured respondents' infringing sales as a share of respondents' and complainant's combined sales of the flowmeters in question. Using this method, respondents' share was [ ] percent in 1984 and [ ] percent in 1985.<sup>46</sup>

---

42

See notes 30-34 supra and accompanying text.

43

Several other companies sell flangeless flowmeters. FF 520.

44

FF 498(c).

45

ID at 92-93.

46

ID at 87. Both the second and third measure define the market as only the sales of complainant and respondents.

The Federal Circuit appears to sanction the use of at least the first and third methods of determining market share.<sup>47</sup> We believe that the third is the best indicator in a case involving intellectual property rights. It is best because the owner of the property right is entitled to all sales involving the exploitation of the right. In fact, although the Federal Circuit in Corning Glass Works appears to sanction the use of both measures, the court in Textron clearly stated that the appropriate test is whether the "the infringer holds, or

---

47

See note 41 supra and accompanying text. The court's discussion in Corning Glass Works was based on the ALJ's finding in Certain Optical Waveguide Fibers which provided in relevant part:

... Given these multiple sources of fiber outside of the domestic industry, it is not clear that respondents' sales and market share were gained at the expense of the domestic industry. See Spring Assemblies, at 43-44, Drill Point Screws, at 20-21.

In any event, the record indicates that respondents' importation and sales of optical waveguide fiber and cable in the United States are de minimus in comparison to both the United States market as a whole, as well as the volume of sales by Corning and its domestic licensees.

Certain Optical Waveguide Fibers, Inv. No. 337-TA-189, USITC Pub. 1754 (Sept. 1985), ID at 105; see also id. at 110 (discussion of market share in context of tendency to injure).

threatens to hold, a significant share of the domestic market in the covered articles.<sup>48</sup> Respondents have captured a large share of the sales entitled to complainant. Thus, the record indicates that significant sales and significant penetration are present, although only one of these is required under Textron to find an effect of the imports to substantially injure the domestic industry.<sup>49</sup>

In addition to requiring complainant to prove that it would have made the sales that respondents made, the majority would make complainant prove its losses with evidence that is documentary in form and up-to-the-minute. We believe that the majority insists

---

48

Textron, 753 F.2d at 1029. Indeed, it is unclear when it would be relevant to calculate market share based on a domestic market broader than the covered articles. Using this broader market definition would preclude relief in any market where the patent had successfully captured a small niche. For example, an inventor of a new type of flowmeter might capture a lucrative 1 percent of the market. An infringer might then take 30 percent of that 1 percent, giving the infringer only a 0.3 percent share of the "total" market. Clearly, the relevant indicator for a patent holder entitled to all the sales under the patent is the 30 percent of its sales captured by the infringer.

49

See text accompanying note 29 supra.

that there is an insufficient basis in the record to support the ALJ's conclusion that [ ] percent of complainant's sales of electromagnetic flowmeters were produced under the patent. The majority thus disregards uncontradicted testimony by complainant's national sales manager, Mr. Dimm, who testified that [ ] percent of its sales of electromagnetic flowmeters were produced under the patent.<sup>50</sup> Admittedly, Mr. Dimm said that complainant did not maintain sales data on the basis of unit size and that his [ ] percent figure was an estimate. He also testified, however, that complainant relies on market share estimates based on this figure to make business decisions.<sup>51</sup> The ALJ determined that Mr. Dimm's testimony was corroborated by respondents.<sup>52</sup>

The ALJ found Mr. Dimm to be a competent witness. Mr. Dimm, an employee of complainant for 11 years who has

---

50

See notes 7-9 supra and accompanying text.

51

Transcript of Hearing in re Certain Unitary Electromagnetic Flowmeters with Sealed Coils ("Transcript"), at 509-10.

52

See FF 498(b) (respondents rely on Frost and Sullivan report); FF 493 ([ - ] percent of respondents' production consists of two-to-four inch meters).

had his current position since 1981, is the individual most knowledgeable about the number and sizes of magnetic flowmeters sold by complainant. <sup>53</sup> His oral testimony was entitled to the weight given to it by the ALJ.

Documentary evidence is typically not required to prove an offense under U.S. criminal or civil law. Oral testimony of a competent witness is often more reliable and probative than documents. Only in rare circumstances, which we need not be concerned with here, is the absence of documentary evidence dispositive. <sup>54</sup>

Nowhere in the statute is it required that complainants provide documentary evidence to the Commission. Commission rules provide that the complaint should include "a statement of facts indicating the effect or tendency to substantially injure. Such a statement would normally include the volume and trend of production, sales, and inventories of the involved domestic article

---

53

FF 492.

54

For example, cases involving the Statute of Frauds require documentation.



...."<sup>55</sup> Again, the rule does not preclude complainant from basing its statement on the knowledge of an informed individual rather than on a compilation of invoices.<sup>56</sup> The only possible relevance of the lack of "written support or calculation to support the witness' approximation of the domestic industry component of Mini-Mag flowmeters"<sup>57</sup> might be to the credibility of the witness. The ALJ is a seasoned lawyer and administrative law judge and thus has substantial expertise in weighing evidence and in determining credibility. He had the opportunity to hear and see the witness, whereas the Commissioners had only a cold transcript and did not hear or see the witness. In the absence of conflicting evidence, it is bad practice as well as arbitrary for the Commission to reverse the ALJ on the competence and credibility of Mr. Dimm. If the Commissioners were concerned about the credibility of a witness, rather than reversing the ALJ on the basis of the

---

55  
19 C.F.R. ( 210.20(a)(8) (1984).

56  
If the rule were to be read to require written records, it would probably be outside of the scope of the Commission's authority.

57  
Review Brief of Respondents, at 12 (Sept. 30, 1986).

transcript, they should have had a hearing and heard the  
58  
witness.

Respondents could have undertaken to calculate the exact level of relevant sales. Complainant apparently determined that it was unnecessary for its day-to-day operations to maintain such data and that it would be too expensive to prepare such information solely for use in  
59  
this proceeding. Complainant did, however, make the relevant invoices available to respondents. Respondents' failure to take advantage of this opportunity may indicate that they too found that such an endeavor would be an unwise investment of time and money. Whatever the reason, Mr. Dimm's testimony is credible and believable.

As described above, the ALJ used the [ ] percent estimate along with the [ ] percent figure from the Frost

---

58

The issue of credibility is typically in the domain of the trier of fact, as are determinations of fact. Although the Commission has the power to review these issues de novo, both administrative economy and the protection of the parties' rights are best served when some deference is given to the ALJ on these matters.

59

Complainant's Submission on the Issues Under Review (Sept. 26, 1986), at 15-16.

and Sullivan Report to calculate the first market share measure: respondents' infringing sales as a share of total market sales of flangeless electromagnetic flowmeters sized two-to-four inches in diameter.<sup>60</sup> The majority's criticism of this measure may be two-fold. First, the majority may find fault with the use of the [ ] percent estimate of production. This has already been adequately discussed. Second, the Frost and Sullivan Report only provides market share data through 1983. Thus, the majority may argue that the Report is out of date and cannot be used to measure market share in 1984 and 1985. This argument fails in the absence of evidence that complainant's market share has decreased since 1983. Unless such evidence exists, the estimated penetration provides a lower bound on respondents' share of the market. If complainant's share has actually increased,<sup>61</sup> then respondents estimated share would be higher. No

---

60

See notes 12-17 & 43-44 supra and accompanying text.

61

Complainant testified that its share of the flangeless market is approximately [50] percent. FF 498, 498(d). The attempt by respondents to argue that this impugns the reliability of the Frost and Sullivan Report is unsuccessful. Reply of Respondents, at 10-14. For example, using the numbers for 1984, see  
(Footnote continued to page 26)

evidence has been presented to indicate that complainant's market share has decreased. Moreover, the Frost and Sullivan Report has no relevance for either the second or the third measure of market penetration.<sup>62</sup> Under these circumstances, a new comprehensive market share study should not be required.

The ALJ also used the [ ] percent estimate to allocate financial and production data, with the obvious result that the relevant portion of complainant's operation followed the same financial trend as the total operation. The ALJ justified this calculation on the grounds that complainant used the same production facilities and employees for the manufacture of flangeless magnetic flowmeters of all sizes. He thus determined that "it is unlikely that profitability, employment and capacity data

---

(Footnote continued from page 25)  
note 16 supra, if complainant's share of the two-to-four inch flangeless flowmeter market was [ ] percent, total sales in the market would be [ ], instead of [ ]. Respondents' share would obviously be higher. If the market share for complainant has increased since 1983, any resulting error in the calculation of respondents' share would clearly be harmless error.

62

See note 46 supra and accompanying text.

for the industry at issue could involve more than a simple allocation, and such an allocation would have no effect on trends." <sup>63</sup> Respondents claim that this proposition is without any factual, logical or legal basis, <sup>64</sup> but do not set forth any reason for this assertion.

[ ] percent of complainant's production is accounted for by articles that exploit the patent. Production of the patented articles occurs on the same machinery with the same employees as the flowmeters outside the claims of the patent. The products that are not within the claims of the patent are smaller versions of the same product. In the absence of contrary evidence, one reasonable inference to draw would be that demand and supply for the patented and non-patented products are <sup>65</sup> determined by the same or similar factors.

---

63

FF 492.

64

Respondents' Review Brief at 10.

65

One variable that is not constant over the last few years is that the patent was issued in late 1983. One might draw the inference that competitors would shift production from the product with patent protection to the ones without. Thus, while complainant's overall sales might be steady or down, sales of the patented (Footnote continued to page 28)

Moreover, even if complainant maintained separate profit-and-loss data for the covered products, such data would be inherently suspect.<sup>66</sup> It is true that sales data might be more reliable than the estimate. There is no reason to believe, however, that the cost allocations chosen by complainant would have been more accurate or, for that matter, different than the estimates on the

---

(Footnote continued from page 27)  
product by complainant might be up. No evidence was presented with respect to this argument. Conversely, Mr. Dimm testified that "the product lends itself to a similar distribution of [sales by] sizes." Transcript, at 509 (May 15, 1986).

66

Because complainant did not maintain this data in the regular course of business, if it had simply prepared such data for the purpose of this investigation, the information would lack credibility because no incentive would be present to produce accurate data. The rationale for the exception to the hearsay rule for business records is informative on this issue. Regularly kept business records are admissible because of their "unusual reliability. ... The very regularity and continuity of the records are calculated to train the recordkeeper in habits of precision; if of a financial nature, the records are periodically checked by balance-striking and audits; and in actual experience the entire business of the nation and many other activities function in reliance upon records of this kind." McCormick on Evidence (306 (Lawyer's ed.) (3d ed. 1984); Fed. R. Civ. P. 803(6)). Thus, the ALJ would have been in the same position of judging the credibility of the witness who presented the data.

record. The allocation of certain common costs of production (e.g., manufacturing overhead) to distinct products is difficult at best.

67

Complainant is being held to a remarkably high burden of proof by the majority. This is in direct contrast

68

---

67

See C. Horngren, Cost Accounting, A Managerial Emphasis 510 (5th ed. 1982).

The relevance of complainant's profit-and-loss data is questionable. Evidence indicating that a complainant's sales and profit margins are increasing might indicate that a firm's financial condition is improving. Such evidence might even show that a firm is doing well. It does not, however, demonstrate the absence of adverse effects of the infringing goods. One recent analysis of section 337 correctly recognized that "an examination of trends in prices, profits, sales, capacity utilization, and inventories tell us more about supply and demand conditions in the industry and in the economy than about the effects of infringement." Feinberg, The Interpretation of Injury Under Section 337, 31 (unpublished study written under contract to USITC).

68

According to a recent study by the Government Accounting Office, many domestic patent holders chose to forego seeking relief at the Commission because of the high price of section 337 litigation. A GAO survey found that costs ranged from \$100,000 to \$1 million, with the costs of some cases as high as \$2.5 million. The level of proof required by the majority will add to this cost and cannot but dissuade other aggrieved parties from seeking relief. Statement of Allan Mendelowitz, Associate Director, National Security and International Affairs Division, GAO, before the Subcommittee on International Trade of the Senate Committee on Finance (May 14, 1986).

to the holdings of the Federal Circuit and past precedent of the majority. In Textron, the Federal Circuit noted:

Both this court and the ITC have acknowledged that the quantum of proof of injury is less in the context of patent, trademark, or copyright infringement, however, than in other types of unfair trade practices, because the holder of the former type of rights is entitled to exclude competitors entirely from using the intellectual property covered by those rights. See Bally/Midway, 714 F.2d at 1124, 219 USPQ at 102; In re Spring Assemblies and Components Thereof, ITC Pub. No. 337-TA-88, 216 USPQ 225, 243

69  
(1981).

For the majority to agree that the "quantum of proof" is lower in a patent case than in a non-intellectual property rights case and then to require mathematical precision with respect to market share and profit and loss data is

70  
inconsistent and unreasonable. One can only guess

---

69  
753 F.2d at 1029.

70  
The Textron court cited the Commission's decision in Certain Spring Assemblies and Components Thereof with approval. In Spring Assemblies, the Commission still recognized the relevance of intellectual property law to section 337:

Under patent law, a patent is a lawful monopoly, and the owner of a valid patent is entitled to 100 percent of the domestic market for the product covered by the patent. Thus, all sales of infringing articles covered by a patent rightfully belong only to the patentee (and/or any  
(Footnote continued to page 31)



what would be involved in meeting the higher quantum of proof required in a non-intellectual property rights case.

With certain modifications to the lost sales  
71  
discussion, we would affirm the ALJ's determination

---

(Footnote continued from page 30)  
licensees). Similarly, any share of the market for a patented article held by an infringer represents a market share that rightfully belongs only to the patentee (and/or any licensees). In determining causation in patent-based cases under section 337, we take into account this rule of patent law. Further, we believe that the requisite connection between the imports and substantial injury to the domestic industry is usually established where it is shown that an infringer holds a significant share of the domestic market for articles covered by the patent or that an infringer has made a significant amount of domestic sales of the covered articles, as such sales rightfully belong only to the patentee. ... This obviously does not contemplate that a single sale lost by a patent holder will automatically result in substantial injury.

Spring Assemblies, at 43-44. The view expressed above is one rational interpretation of the injury requirement and the Federal Circuit in Textron and Corning Glass Works relies extensively on this passage.

Unfortunately, the Commission added one additional sentence: "The complainant is not released from the burden of establishing substantial injury, or of showing the requisite causal connection between the imports and injury." It is difficult to find a connection between this sentence and the earlier quoted sentences. Nor is it easy to rationalize it with the Federal Circuit's holdings that the quantum of injury is judged by the level of infringing sales and market share.

71

We believe that it was improper for the ALJ to look beyond the volume of sales by respondents.

(Footnote continued on page 32)

that respondents' imports have had an effect to cause substantial injury to the domestic industry. We would also affirm his determination that a tendency to injure the domestic industry has been proven.<sup>72</sup>

---

(Footnote continued from page 31)

Although such an inquiry may be relevant in determining whether a patent holder in a district court action is entitled to lost profits as opposed to a reasonable royalty, see King Instrument Corp. v. Otari Corp., 767 F.2d 853, 864 (Fed. Cir. 1985), the Commission is not engaged in such an inquiry. See notes 37-41 supra and accompanying text.

72

See note 23 supra and accompanying text. In general, evidence of an effect to cause injury will also suffice to prove tendency to injure.

Certificate Of Service

I, Kenneth R. Mason, hereby certify that the Attached Views was served upon Juan Cockburn, Esq., and Gary Rinkerman, Esq., and upon the following parties via first class mail and air mail where necessary, on December 2, 1986.

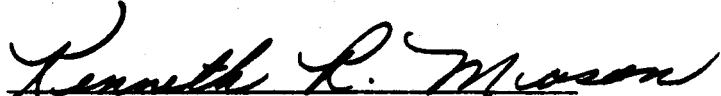
  
Kenneth R. Mason, Secretary  
U.S. International Trade Commission  
701 E Street, N.W.  
Washington, D.C. 20436

For Complainant Fischer & Porter Company:

John M. Calimafde, Esq.  
Hopgood, Calimafde, Kalil,  
Blaustein and Judlowe  
Lincoln Building  
60 East 42nd Street  
New York, New York 10165

For Respondents Krohne-America, Inc. and  
Krohne Messtechnik GmbH & Company KG:

Tom M. Schaumberg, Esq.  
Plaia and Schaumberg  
1019 19th Street, N.W., PH-II  
Washington, D.C. 20036

Robert A. Cesari, Esq.  
Cesari and McKenna  
Union Wharf East  
Boston, Massachusetts 02109

GOVERNMENT AGENCIES:

Mr. Charles S. Stark  
Antitrust Div./U.S. Dept. of Justice  
Room 7115, Main Justice  
Pennsylvania Avenue & Tenth Street, N.W.  
Washington, D.C. 20530

Edward F. Glynn, Jr., Esq.  
Asst. Dir. for Int'l Antitrust  
Federal Trade Commission  
Room 502-4, Logan Building  
Washington, D.C. 20580

Darrel J. Grinstead, Esq.  
Dept. of Health & Human Services  
Room 5362, North Building  
330 Independence Avenue, S.W.  
Washington, D.C. 20201

Michael T. Schmitz  
Chief Counsel  
U.S. Customs Service  
1301 Constitution Avenue, N.W.  
Washington, D.C. 20229

(PUBLIC VERSION)

UNITED STATES INTERNATIONAL TRADE COMMISSION  
Washington, D.C.

In the Matter of )  
 )  
CERTAIN UNITARY ELECTROMAGNETIC )  
FLOWMETERS WITH SEALED COIL )

Investigation No. 337-TA-230

INITIAL DETERMINATION

Paul J. Luckern, Administrative Law Judge

Pursuant to the notice of investigation in this matter (50 Fed. Reg. 45175, 45176 October 30, 1985), this is the administrative law judge's initial determination under Rule 210.53 of the Rules of Practice and Procedure of this Commission, 19 C.F.R. § 210.53. The administrative law judge hereby determines, after a review of the briefs of the parties and of the record developed at the hearing, that there is a violation of section 337 of the Tariff Act of 1930, as amended (19 U.S.C. § 1337), hereinafter section 337 in the unauthorized importation into the United States, and in the sale, of certain unitary electromagnetic flowmeters with sealed coils by reason of alleged infringement of claims 1-5 of U.S. Letters Patent No. 4,420,982, with the effect and tendency to destroy or substantially injure an industry efficiently and economically operated in the United States.

RECEIVED  
U.S. INTERNATIONAL TRADE COMMISSION  
WASHINGTON, D.C. 20540

31 AUG 14 1985

RECEIVED

Appearances of Counsel

FOR COMPLAINANT FISCHER & PORTER COMPANY:

John M. Calimafde, Esq.; William G. Todd, Esq.;  
Dennis J. Mondolino, Esq.; James M. Rhodes, Esq.;  
Eve Kunen, Esq.  
HOPGOOD, CALIMAFDE, KALIL, BLAUSTEIN & JUDLOWE  
Lincoln Building  
60 East 42nd Street  
New York, New York 10165

FOR RESPONDENTS KROHNE-AMERICA, INC.; KROHNE MESSTECHNIK GmbH & COMPANY KG:

Tom M. Schaumberg, Esq.; Robert S. Budoff, Esq.  
PLAIA & SCHAUMBERG, CHARTERED  
1019 - 19th Street, N.W., PH-2  
Washington, D.C. 20036

Robert A. Cesari, Esq.; John F. McKenna, Esq.;  
Martin J. O'Donnell, Esq.  
CESARI AND MCKENNA  
Union Wharf East  
Boston, Massachusetts 02109

FOR THE COMMISSION INVESTIGATIVE STAFF

Juan Cockburn, Esq.  
Gary Rinkerman, Esq.

CERTIFICATE OF SERVICE

I, Kenneth R. Mason, hereby certify that the attached Initial Determination (Public Version) was served upon Juan Cockburn, Esq., and Gary Rinkerman, Esq., and upon the following parties via first class mail, and air mail where necessary, on August 14, 1986.

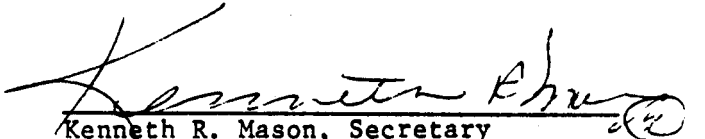
  
Kenneth R. Mason, Secretary  
U.S. International Trade Commission  
701 E Street, N. W.  
Washington, D.C. 20436

FOR COMPLAINANT FISCHER & PORTER COMPANY:

John M. Calimafde, Esq.; William G. Todd, Esq.;  
Dennis J. Mondolino, Esq.; James M. Rhodes, Esq.;  
Eve Kunen, Esq.  
HOPGOOD, CALIMAFDE, KALIL, BLAUSTEIN & JUDLOWE  
Lincoln Building  
60 East 42nd Street  
New York, New York 10165

RESPONDENTS

FOR KROHNE-AMERICA, INC.; KROHNE MESSTECHNIK GmbH & COMPANY KG:

Tom M. Schaumberg, Esq.; Robert S. Budoff, Esq.  
PLAIA & SCHAUMBERG, CHARTERED  
1019 - 19th Street, N.W., PH-2  
Washington, D.C. 20036

Robert A. Cesari, Esq.; John F. McKenna, Esq.  
CESARI AND McKENNA  
Union Wharf East  
Boston, Massachusetts 02109

GOVERNMENT AGENCIES:

Mr. Charles S. Stark  
Antitrust Div./U.S. Dept. of Justice  
Room 7115, Main Justice  
Pennsylvania Avenue & Tenth Street, N.W.  
Washington, D.C. 20530

Edward F. Glynn, Jr., Esq.  
Asst. Dir. for Int'l Antitrust  
Federal Trade Commission  
Room 502-4, Logan Building  
Washington, D.C. 20580

Darrel J. Grinstead, Esq.  
Dept. of Health & Human Services  
Room 5362, North Building  
330 Independence Avenue, S.W.  
Washington, D.C. 20201

Richard Abbey, Esq.  
Chief Counsel  
U.S. Customs Service  
1301 Constitution Avenue, N.W.  
Washington, D.C. 20229



TABLE OF CONTENTS

<u>TITLE</u>	<u>PAGE</u>
PROCEDURAL HISTORY .....	1
JURISDICTION .....	4
OPINION .....	5
Introduction .....	5
A. Validity of the '982 Patent .....	8
35 U.S.C. § 112 .....	8
35 U.S.C. § 102 .....	19
35 U.S.C. § 103 .....	35
(a) Prior Art .....	37
(b) Secondary Considerations .....	45
B. Infringement of the '982 Patent .....	47
Krohne's Less Than 2 Inch Meter .....	49
Krohne's 2 Inch and Above Meter .....	52
C. Full and Fair Disclosure .....	63
Failure to Cite the British Sybron Patent .....	65
Inventorship Question .....	69
D. Laches .....	72
E. Importation and Sale .....	75
F. Domestic Industry .....	75
G. Efficient and Economic Operations .....	77
H. Injury .....	80

Effect to Substantially Injure .....	80
(a) Domestic Industry Decline in Sales and .. Profits .....	85
(b) Domestic Industry Operation Well Below Capacity and Increased Inventory .....	86
(c) Market Share .....	86
(d) Lost Sales .....	87
(i) .....	89
(ii) .....	90
(iii) .....	91
(iv) .....	92
(e) Price Competition .....	93
Tendency to Substantially Injure .....	95
FINDINGS OF FACT .....	100
JURISDICTION .....	100
THE PARTIES AND THE PRODUCTS .....	100
THE '982 PATENT .....	102
Claims of the '982 Patent .....	103
Disclosure of the '982 Patent .....	104
PROSECUTION OF THE '982 PATENT .....	113
RELATED PATENTS AND APPLICATIONS .....	118
PRIOR ART .....	135
British Sybron Patent 1,424,875 .....	135
German Patent 2,040,682 .....	141

Instrument Engineers' Handbook .....	145
U.S. Patent No. 3,875,969 .....	210
VALIDITY & INFRINGEMENT .....	146
IMPORTATION AND SALE .....	253
DOMESTIC INDUSTRY .....	254
SUBSTANTIAL INJURY .....	263
Overall Market .....	265
Flangeless v. Flanged .....	268
F&P's Ceramic Core Supply .....	274
Overall Import Sales .....	277
Lost Sales .....	278
Other Competition .....	291
Price Competition .....	294
TENDENCY TO SUBSTANTIALLY INJURE .....	300
CONCLUSIONS OF LAW .....	304
INITIAL DETERMINATION AND ORDER .....	306

## ABBREVIATIONS

CPFF - Complainant's Proposed Findings of Fact  
CPost - Complainant's Posthearing Brief  
CPost R - Complainant's Posthearing Reply Brief  
CPX - Complainant's physical exhibit  
CX - Complainant's exhibit  
Exh. - Exhibit  
FF - Findings of Fact  
RPFF - Respondents' Proposed Findings of Fact  
RPFFR - Respondents' Reply Proposed Findings of Fact  
RPostR - Respondents' Posthearing Reply Brief  
RPX - Respondents' physical exhibit  
SPFF - Staff's Proposed Findings of Fact  
SPost - Staff's Posthearing Brief  
SX - Staff's exhibit  
Tr. - Transcript

## PROCEDURAL HISTORY

On September 24, 1985 a complaint was filed with the Commission, pursuant to section 337 of the Tariff Act of 1930 on behalf of complainant Fischer & Porter Company (F&P), 200 Witmar Road, Horsham, Pennsylvania. An amendment to the complaint was filed on October 10, 1985. The complaint, as amended, alleged unfair methods of competition and unfair acts in the importation of certain unitary electromagnetic flowmeters with sealed coils into the United States, or in their sale, by reason of alleged infringement of the claims of U. S. Letters Patent 4,420,982 ('82 patent). The complaint further alleged that the effect or tendency of the unfair methods of competition and unfair acts is to destroy or substantially injure an industry, efficiently and economically operated, in the United States. The complaint requested that the Commission institute an investigation, and after a full investigation, issue a permanent exclusion order and permanent cease and desist orders.

Upon consideration of the complaint, the Commission, on October 21, 1985, ordered, pursuant to subsection (b) of section 337 of the Tariff Act of 1930, that an investigation be instituted to determine whether there is a violation of subsection (a) of section 337 in the unlawful importation of certain unitary electromagnetic flowmeters with sealed coils into the United States, or in their sale, by reason of alleged infringement of the claims of the '82 patent, the effect or tendency of which is to destroy or substantially injure an industry, efficiently and economically operated, in the United States. The notice of investigation was served on the parties on October 23, 1985 and published in the Federal Register on October 30, 1985. (50 Fed. Reg. 45175, 45176).

The following parties were named as respondents in the notice of investigation:

Krohne Messtechnik GmbH  
& Company KG  
P.O. Box 100 970  
4100 Duisburg  
Federal Republic of Germany  
(Krohne)

Krohne-America, Inc.  
Dearborn Road  
Peabody, Massachusetts 01960  
(Krohne-America)

Responses to the complaint and notice of investigation were filed with the Commission by the named respondents (Krohne).

A prehearing conference was held on May 14, 1986 and the hearing commenced on the same day immediately following the prehearing conference. Appearances were made by the complainant, staff and the named respondents. Evidentiary Stipulations and Factual Stipulations were admitted into evidence (RX-113). On oral motion by all the parties depositions, as identified in the respective exhibit lists, were received into evidence for the truth of the statements therein. (Tr. at 1890, 1891). The hearing concluded on May 22, 1986. Closing arguments were heard on June 17, 1986.

There is pending a motion made by the respondents during the hearing to exclude all testimony relative to the Krohne flowmeters having a conduit diameter less than 2 inches on the ground that those flowmeters are not relevant to the investigation. (Tr. at 582, 583). The motion is denied on mootness in view of the finding of non-infringement by the Krohne flowmeter with less than 2 inch conduit diameter. See infra at 49-52.

Complainant on June 10, 1986 also moved to strike the "uncorroborated, double-hearsay, irrelevant testimony of Fredrich Hofmann." (Motion Docket No. 230-6). In the closing argument complainant's counsel stated that

complainant was not moving to strike Mr. Hofmann's written witness statement (direct testimony) (RX-11) but was moving only to strike Hofmann's live testimony which was

"based on test data which he observed while in Germany or test information which he had received from another in Germany or based on speculation which, according to his testimony, came from conversations he had with other people in the company in Germany.

So that the testimony that I move be stricken is the testimony relating to the force sharing between the housing and the spool, which he said was based on tests the results of which were reported to him by somebody, his testimony relating to the division of magnetic flux between the housing and the strap, which was based on permeability information given to him by somebody.

And he also gave testimony with regard to the ability of the spool to withstand compressive forces, and that was speculation. He did not testify with regard to any tests that were conducted on the ability of the spool to withstand the compressive forces."

JUDGE LUCKERN: And I can so interpret your motion to strike that way.

MR. CALIMAFDE: Yes. (Tr. at 2011, 2012, 2013).

Motion No. 230-6 is denied. However no weight has been given to what respondents admitted are "Mr. Hofmann's "conclusions that (1) the [Krohne] housing does not bear a substantial amount of the compressive force and (2) the [Krohne] housing does not have more than 57% of the total flux of the magnetic circuit traveling therethrough". See infra at 57-63.

In addition there is pending respondents' motion for production of certain attorney client documents of complainant on the ground of alleged conduct before the Patent Office. This motion is denied. See infra at 65-69.

With respect to evidentiary matters, the parties have agreed that the depositions admitted into evidence may be used for any purpose. (Tr. at 1890, 1891, 1892). There are also evidentiary stipulations (RX-113) with respect to the use of copies of documents, the use of uncertified copies of patents and publications and the authenticity of documents produced from a party's files.

On July 29, 1986 Order NO. 14 issued which reopened the record and admitted into evidence a Frost and Sullivan report (CX-20) in its entirety. (CX-20).

The issues have been briefed and proposed findings of fact and conclusions of law submitted by the parties. The staff took no position with respect to either the validity of the '82 patent, its enforceability or its infringement (with the exception of the Krohne flowmeters having conduit diameter less than 2 inches (SPost at 7-10)). The matter is now ready for decision.

This initial determination is based on the entire record including the evidentiary record compiled at the hearing, the exhibits admitted into evidence, and the proposed findings of fact and conclusions of law and supporting memoranda filed by the parties. The administrative law judge has also taken into account his observation of the witnesses who appeared before him during the hearing and their demeanor. Proposed findings, not herein adopted, either in the form submitted or in substance, are rejected either as not supported by the evidence or as involving immaterial matters. The findings of fact include references to supporting evidentiary items in the record. Such references are intended to serve as guides to the testimony and exhibits supporting the findings of fact. They do not necessarily represent complete summaries of the evidence supporting each finding.

#### JURISDICTION

The Commission has in rem and subject matter jurisdiction in this investigation. (FF 1). It also has in personam jurisdiction. (FF 2).



## OPINION

### Introduction

This patent-based investigation under section 337 concerns the importation from Krohne, in the Federal Republic of Germany, into the United States of certain unitary electromagnetic flowmeters with sealed coils. These flowmeters are known as the ALTOFLUX X-1000 and the DELTAFLUX magnetic flowmeters. The DELTAFLUX flowmeters are available in sizes 1/2", 1", 1 1/2", 2", 3" and 4" pipe diameter conduit. The ALTOFLUX flowmeters are available in 1/10", 1/8", 1/4", 3/8" pipe diameter conduit or meter size and all of the DELTAFLUX flowmeter sizes. (FF 11). Since December 1983 Krohne America has offered for sale and sold in the United States ALTOFLUX X-1000 and DELTAFLUX magnetic flowmeters. (FF 381, 439(d)). Krohne publicly introduced its magnetic flowmeters with ceramic flow tubes in June 1982 at the Achema trade show in Frankfurt, Federal Republic of Germany. The ALTOFLUX and DELTAFLUX were first sold in the United States on August 24, 1982 and November 24, 1982 respectively. (FF 381).

Complainant F&P alleges that the ALTOFLUX X-1000 and DELTAFLUX magnetic flowmeters in conduit diameter sizes 2 inches and above (represented by CPX-23, a Krohne 3 inch DELTAFLUX flowmeter) (2 inch and above) infringe claims 1 through 5 of the '82 patent and in conduit diameter sizes less than 2 inches (represented by CPX-24, a Krohne 1/4 inch ALTOFLUX flowmeter) (less than 2 inch) infringe claims 1, 2 and 5 of the '82 patent. (Tr. at 664).

The '82 patent titled "Unitary Electromagnetic Flowmeter With Sealed Coils" issued to inventor Roy F. Schmoock on December 20, 1983 on application Ser. No. 398,809 filed July 16, 1982. (FF 15). The '82 patent on its face is assigned to F&P.

Under the '982 patent complainant F&P sells two models of electromagnetic flowmeters. These flowmeters are designated by the trade names MINI-MAG and K-MAG. (FF 5, 334). Complainant's MINI-MAG and K-MAG flowmeters in sizes less than 2 inch are not built in accordance with the '982 patent. (FF 5). Complainant has admitted that the domestic industry comprises those facilities dedicated to flowmeters in sizes 2 inches and above. (Tr. at 2131, 2132).

Electromagnetic flowmeters are especially adapted to measure the volumetric flow rates of fluids which present difficult handling problems, such as corrosive acids, sewage and slurries. Because such flowmeters are free of flow obstructions, the flowmeters do not tend to plug. (FF 20).

The concept of an electromagnetic flowmeter is not novel with inventor Schmoock. Electromagnetic flowmeters were described in the prior art as early as 1969. (FF 101). They are disclosed for example in U.S. Patent Nos. 3,695,104; 3,824,856; 3,783,687 and 3,965,738. (FF 20).

The basic elements of an electromagnetic flowmeter include a length of straight insulated pipe or flow tube, a set of electromagnetic coils to generate an electromagnetic field whose lines of flux are mutually perpendicular to the longitudinal axis of the flow of liquid through the insulated pipe and to the transverse axis along which a pair of electrodes are located at diametrically opposed positions with respect to the flow. In operation the liquid which passes through the flowmeter becomes the electrical conductor. As the liquid flows through or interrupts the magnetic lines of force set up by the flowmeter's electromagnets, a voltage is induced in the liquid which is directly proportional to the velocity of the liquid. The voltage is received or sensed by the flowmeter's electrodes which can be read on a voltmeter. The induced voltage is not affected by temperature, viscosity, turbulence or conductivity so long as the conductivity of the measured liquid is above a minimum threshold level. (FF 21, 331, 343).

The electromagnetic flowmeter's operating principles are based on Faraday's law of induction which states that the voltage induced across any conductor as it moves at right angles through a magnetic field will be proportional to the velocity of that conductor. The metered fluid constitutes effectively a series of fluid conductors moving through the magnetic field; the more rapid the rate of flow, the greater the instantaneous value of the voltage established at the electrodes. (FF 21).

The claimed electromagnetic flowmeter unit of the '982 patent is flangeless and interposable between the end flanges of the upstream and downstream pipe of a line conducting a fluid whose flow rate is to be metered. The end flanges of the pipes have a predetermined diameter and a circle of bolt holes. Briefly stated the claimed flangeless electromagnetic flowmeter unit comprises a cylindrical metal housing, a non-magnetic spool, a pair of electromagnetic coils and a pair of electrodes. (FF 17, 19, 27).

In the post-hearing submissions, the parties have raised the following contested issues to determine whether or not respondents' importation and sale in the United States of the accused flowmeters violates section 337: (1) whether claims 1 through 5 of the '982 patent are not valid under sections 102 (anticipation), 103 (obviousness), and/or 112 (enablement) of Title 35 of the United States Code; (2) whether claims 1 through 5 of the '982 patent have been infringed by the respondents and if so whether there is wilful infringement; (3) whether the '982 patent is not valid and/or unenforceable because complainant abused the trust of the United States Patent and Trademark Office and failed to fulfill its duty of full and fair disclosure; (4) whether complainant is estopped by laches from asserting infringement; (5) whether a domestic industry exists; (6) whether the domestic industry is economically and efficiently operated; and (7) whether respondents' activities have the

effect and tendency to substantially injure any domestic industry.<sup>1/</sup>

A. Validity of the '982 Patent

35 U.S.C. § 112

Under 35 U.S.C. §282, respondents have the burden of proof by clear and convincing evidence in establishing that the '982 patent has not met the standards of section 112. Solder Removal Co. v. International Trade Commission, 582 F.2d 28, 199 U.S.P.Q. 129, 132, 133 (CCPA 1978); Lindemann Maschinenfabrik GMBH v. Am. Hoist & Derrick 730 F.2d 1452, 1459, 221 U.S.P.Q. 481, 486 (Fed. Cir. 1984).

Pertinent to the section 112 issues are the first paragraph (pertinent portion) and second paragraph of 35 U.S.C. § 112:

The specification shall contain a written description of the invention, and of the manner and process of making and using it, in such full, clear, and concise, and exact terms as to enable any person skilled in the art to which it pertains, or with which it is most nearly connected, to make and use the same, . . . .

---

<sup>1/</sup> In closing argument respondents' counsel had no problem with complainant's definition of the domestic industry comprising those facilities dedicated to flowmeters in sizes two inches and above but was not sure that there is "any evidence on that subject." (Tr. at 2133). With respect to whether the domestic industry is economically and efficiently operated respondents' counsel represented:

Your Honor, the only reservation we have concerning efficiency and economy . . . becomes the arguments that we have made about Fischer and Porter's own difficulties that they have self-generated in the marketplace. There is testimony about inadequate service. There is testimony about dissatisfaction with their product. That kind of evidence, we believe, has a bearing on the injury case and also tendency to injure. As far as whether they have spent money on facilities and so on, I really don't think you need a stipulation on that, Your Honor. I think they have a lot of facts in the record. (Tr. at 2132).

The specification shall conclude with one or more claims particularly pointing out and distinctly claiming the subject matter which the applicant regards as his invention.

The first paragraph of section 112 manifests the statutory intent to require a patentee to describe the claimed invention so that others may construct and use it after expiration of the patent and to inform the public during the life of the patent of the limits of the asserted "monopolization" so that it may be known which features may be safely used or manufactured without a license and which may not. Scriber-Schroth Co. v. Cleveland Trust Co. 305 U.S. 47 39. U.S.P.Q. 242, 245, 246 (1938) Certain Limited Cell Culture Microcarriers, Inv. No. 337-TA-129, 221 U.S.P.Q. 1165, 1171 (USITC 1983).

The second paragraph of section 112 is essentially a requirement for precision and definiteness of claim language. If the scope of subject matter embraced by a claim is clear, and if the applicant has not indicated that he intends a claim to be of a different scope, the claim does particularly point out and distinctly claim the subject matter which the applicant regards as his claimed invention. Then if the "enabling" disclosure of a specification is not commensurate in scope with the claimed subject matter, that fact does not render the claim imprecise or indefinite or otherwise not in compliance with the second paragraph of section 112; rather, the claim is based on an insufficient disclosure under the first paragraph of 35 U.S.C. § 112. In re Borkowski, 422 F.2d 904, 909, 164 U.S.P.Q. 642, 645 (C.C.P.A. 1970).

To satisfy section 112, a patent specification must be sufficiently complete to enable one of ordinary skill in the art to make the invention without undue experimentation. Enablement is the criterion. It is a legal issue. Raytheon Co. v. Roper Corp. 724 F.2d 951, 220 U.S.P.Q. 592, 599 (Fed.

Cir. 1983). Every experimental detail need not be set forth in the written specification if the skill in the art is such that the disclosure enables one to make the invention. Martin, Aebi and Ebner v. Johnson, 454 F.2d 746, 172 U.S.P.Q. 391 395 (C.C.P.A. 1972). If the claims, read in the light of the specification, reasonably apprise those skilled in the art both of the utilization and scope of the invention, and if the language is as precise as the subject matter permits, the courts can demand no more. Georgia-Pacific Corp. v. U.S. Plywood Corp. 258 F.2d 124, 136, 118 U.S.P.Q. 122, 132 (2d Cir. 1958). Claims are to be read and construed in light of the specification and the prosecution history of the patent. Further, claims should be so construed, if possible, to sustain their validity. Carman Industries Inc. v. Wald, 724 F. 2d 932, 937 n.5, 220 U.S.P.Q. 481, 485 n5 (Fed. Cir. 1983); Klein v. Russell, 86 U.S. 433, 466 (1874); Turrill v. Michigan S & N. I. R. R., 68 U.S. 491, 510 (1864). The specification need not disclose what is well known in the art. In re Myers, 410 F.2d 420, 161 U.S.P.Q. 668 671 (C.C.P.A. 1969).

Respondents argue that the means by which the alleged force sharing between the spool and the housing of the claimed flowmeter of the '982 patent is accomplished is not taught in the '982 patent nor is the level of "sharing" anywhere described in the '982 patent. Hence it is argued that the '982 patented disclosure is inadequate both for failing to teach how to make and use the invention and for failing to provide claims which point out the limits of the invention. (RPost at 13).

Respondents also argue:

35 U.S.C. § 112 requires that the invention be described 'in such full, clear and concise terms that it can be understood by one of ordinary skill in the art.' Complainant's expert Blanco described the sharing of the load between the housing and the spool as 'critical' to the invention, yet he admitted that nowhere is this described in the drawings or in the specification. He testified that he could find it

only by inference in the claims. (Blanco deposition, May 1, 1986) [RPX-10]. Nor could he determine from the disclosure of the patent just where, or how, or to what extent forces are transmitted between the spool and the housing. (*ibid.*) Thus, the patent fails to teach one of ordinary skill in the art how to practice the asserted 'invention.' (RPost at 19).

Complainant argues that the '982 patent describes the combination of a housing joined to the flow tube; that the drawings of the '982 patent illustrate the combination and show a strong housing of substantial thickness which is manifestly not a thin strip of metal seated on and merely covering the flow tube; and that in the title of the patent, in the specification and in the claims, words such as "unitary", "unit", "joined" and "mated" are used to characterize the connection between the housing and tube. It is argued that a natural, normal and unstrained reading of the '982 patent can leave no doubt that the housing is uniting with or joined with the flow tube; and that one skilled in the art would understand that such mechanical joining between the rugged housing and strong flow tube would necessarily result in load sharing and that he would not require "words" to understand that. (CPostR at 5).

Based on the foregoing the administrative law judge must decide whether respondents have sustained their burden in establishing that a person of ordinary skill in the art, with the '982 patent before him, would not understand that there is described and claimed in the '982 patent a flangeless electromagnetic flowmeter wherein any applied compressive force is shared by the spool and the housing of the claimed flowmeter and also would not be able to be determine from the specification the extent of any sharing. Seattle Box Co., Inc. v. Industrial Crating & Packing, Inc. 731 F.2d 818, 826, 221 U.S.P.Q. 568, 574. (Fed. Cir. 1984).

The specification of the '982 patent discloses that the claimed flowmeter includes a non-magnetic spool of high mechanical strength and having end

flanges. The spool provides a flow conduit for the fluid to be metered. (FF 29). Surrounding the spool and concentric therewith is a cylindrical housing formed of complementary half-pieces which include arcuate end plates that join the corresponding end flanges of the spool, to define an enclosed inner chamber. (FF 30). The spool in turn is subjected to a compressive force which force is generated by bolts which bridge the flanges of the upstream and downstream pipes between which the flowmeter unit is interposed in the fluid line. (FF 32). The compressive force is applied coaxially by action of the two pipe flanges. (FF 140). Thus in the F&P Type 10 D 1475 3 inch MINI-MAG (CPX-1, CPX-36) there is a birdcage arrangement through four bolts with two pipe flanges on each side of the flowmeter unit. A compressive force is applied by tightening the four bolts until the two pipe flanges grip the flowmeter unit in between and sufficient fluid seal is provided. (FF 141).

A review of the portion of deposition testimony of Prof. Ernesto E. Blanco, complainant's expert (FF 137), apparently relied upon by respondents, shows that Prof. Blanco did make reference to clause B of claim 1 of the '982 patent. (RPX-10 at 45; FF 17). Moreover in deposition he specifically testified that the '982 patent teaches that the housing of the claimed flowmeter "takes part of the housing load applied by the flanges [of the upstream and downstream pipes through the bridged bolts] at both ends;" that while it is very "difficult to tell [how much compressive force is taken by the housing] because we have here an indeterminate condition" it can be done if "you know the cross-sections and the model of elasticity;" and that "from the design of the system, since the spool is in contact with the housing,



whatever loads are applied to the spool will also be shared by the housing." (RPX-10 at 42, 43, 44).

At the hearing Prof. Blanco, when asked where in the '982 patent there was a discussion of the sharing of compressive forces between the housing and the spool of the claimed flowmeter, relied on the use of the word "unit" in the introductory clause of independent claim 1, <sup>2/</sup>viz. "A flangeless electromagnetic flowmeter unit interposable between the end flanges of the upstream and downstream pipes of a line conducting a fluid whose flow rate is to be metered, the end flanges of the pipes having a predetermined diameter and a circle of bolt holes, said unit comprising;"; and on clause A of claim 1 viz.

A. a cylindrical metal housing having an external diameter which is smaller than that of the circle whereby when the unit is interposed between the end flanges of the pipes, the housing lies within the circle and the flanges are bridged by bolts passing through the holes to encage the unit and subject it to a compressive force effecting a fluid seal; (FF 17) (Emphasis added).

The above language of the patent meant to Prof. Blanco that the claimed flowmeter unit, which includes the housing and spool, is subjected to a compressive force. (FF 196). He explained that according to clause A the housing lies within a circle of bolts and the pipe flanges are bridged by the bolts passing through the holes of the pipe flanges to encage the unit, not just the housing and to subject the unit to a compressive force effecting a fluid seal. The housing and the spool are a unit with the two of them working

---

2/ Claim 1 is the only independent claim of the '982 patent. (FF 17). The language of independent claim 1 is incorporated by reference in all of the remaining claims. Hence any testimony relating to claim 1 would inherently relate to the remaining four claims in issue.

together in sharing the load of the system. (FF 139). Prof. Blanco also made reference to clause B of independent claim 1 which clause meant to Prof. Blanco that the non-magnetic spool is subjected to the compressive force because clause B specifically refers to "said compressive force." To Prof. Blanco the word "said" can only refer to the "compressive force" recited in clause A of claim 1. (FF 197). Clause B of claim 1 reads:

B. a non-magnetic spool coaxially disposed within said housing and provided with end flanges which are seated against the ends of the upstream and downstream pipes and define with said housing an internal cavity, said spool having a longitudinal flow axis which joins the upstream and downstream pipes, said spool having a strength sufficient to withstand the pressure of fluid flowing in the conduit and said compressive force; (Emphasis added) (FF 17).

To Prof. Blanco the compressive force in claim 1 should be interpreted, according to the language of claim 1, as being applied simultaneously to each of the housing and the spool, which form a unit, in varying degrees and to both at all times. (FF 196).

Prof. Blanco testified that claim 1 calls for the "unit" to take compressive force and that the only parts of the unit that an engineer would take into account as being compressed are the parts designed to be compressed, viz. the cylindrical metal housing and the non-metallic spool. Coils in claim 1 are not designed to be compressed. (FF 197).

According to Prof. Blanco the sharing of the compressive force by the spool and the housing of the flowmeter unit, as taught by claim 1 of the '982 patent, finds support when claim 1 is read in light of the specification of the '982 patent. Thus he testified that the specification teaches that the housing of the claimed spool includes end plates that join the corresponding ends of the spool to define the inner chamber (FF 25, 198); that surrounding the spool and concentric therewith is the housing formed of complimentary half

pieces which include arcuate end plates that join the corresponding end flanges of the spool to define an enclosed inner chamber (FF 30, 198); and that the opposing ends of the split housing are provided with plates whose inner peripheries mate with the outer peripheries of end flanges of the spool. (FF 35, 198). The intentional use of the word "join", according to Prof. Blanco, establishes that the joined parts are intentionally touching, by design, and transferring loads in between. (FF 198, 209). The term "mate", according to Prof. Blanco mean, "join". (FF 198, 210). Conventional methods of joining parts, such that applied forces are transferred deliberately by design, are through welding or press fitting. (FF 198). Prof. Blanco noted that the inventor Schmoock intended a joining to be in the nature of seam welding and thus such that compressive forces would be transferred. In support Prof. Blanco referenced the following portion of the '982 patent:

Surrounding the lined metal spool 10 and concentric therewith is a split cylindrical housing or casing formed by complementary half-pieces . . . the longitudinal edges of these pieces being seam welded or otherwise joined together to complete the housing. (Emphasis added) (FF 33).

He considered "joined" in the above to be used exactly the same as where the word "join" is used in the '982 patent for joining the end plates of the housing to the end flanges of the spool, such as:

Surrounding the spool and concentric therewith is a cylindrical housing . . . formed of complementary half pieces which include arcuate end plates that join the corresponding end flanges of the spool . . . (FF 208). (See also FF 25, 30, 35).

The testimony of respondents' expert, Mr. Liptak (FF 238), that the citations to the '982 specification, relied upon by Prof. Blanco, make certain that the housing does not get loose, that the housing is kept in position, and that the housing does not shift around the ceramic spool and damage the wire

(FF 258) and Mr. Liptak's testimony that a joining of the housing to the spool serves to provide a strong seal from environmental vapors (FF 253) does not detract from Prof. Blanco's testimony that the design of the flowmeter, according to the '982 specification, is for a physical touching of the spool and housing such that applied compressive force is shared. A joining of the spool and housing by seam welding would inherently make certain that the housing does not get loose, that the housing is kept in position, that the housing does not shift, and that environmental vapors are kept out of the housing.

Mr. Liptak testified that a beige colored housing on top of CPX-21 (F&P 3 inch MINI-MAG Flowmeter) has "nothing to do with the ['982] patent" although the beige housing is joined to the remaining portion of the flowmeter. (FF 253). It is clear however, on observation of CPX-21, that any compressive force generated by the bolts is not applied to the beige housing and hence it would not be intended that the beige housing would share any applied compressive force.

Not only is there testimony of Prof. Blanco that the compressive force applied to the spool is inherently shared by the housing of the claimed flowmeter unit but there is testimony of respondents' expert Mr. Liptak that if a spool of a flowmeter is in physical contact with a cover in a British Sybron patent, compression forces applied to the spool will be transmitted to the cover and that this would be apparent to those skilled in the flowmeter art<sup>3/</sup> and even those not skilled in the flowmeter art. (FF 253).

---

<sup>3/</sup> The record establishes that a person of ordinary skill in the flowmeter art, in the mid 1970's would have had 5-10 years experience in flowmeter  
(Footnote continued to page 17)

Mr. Liptak further testified that in the F&P 3 inch electromagnetic flowmeter (CPX-29), which is made according to the '982 patent (See infra at 52-55), if there are compressive forces acting on the spool of a flowmeter and a housing is in physical contact with the spool, there will be a transmission of compressive force. Mr. Liptak knows that in practice in the F&P 3 inch electromagnetic flowmeter the spool is welded to the housing. (FF 275). Hence there has to be a transmission of compressive force due to the joining of the spool and housing in the F&P 3 inch electromagnetic flowmeter.

Mr. Liptak also testified that when bolts which engage an electromagnetic flowmeter are tightened, the pipe flanges exert a compressive force on the spool and as the force is applied to the spool at least a part of that force is transferred to the housing if the housing is connected to the spool. (FF 285). Significantly Mr. Liptak testified that the force to which the spool is subjected and which the housing receives through transmission, is a function of the method of joining the housing to the spool. (FF 280). The '982 patent specifically discloses that the spool is joined to the housing (FF 25, 30, 35) and indicates that a joining can be done by seam welding. (FF 33).

While Mr. Liptak also testified that in the claimed flowmeter consisting of the spool, housing, electrodes and coils, the spool only will "withstand" the compressive force, he provided no explanation why the housing which is joined to the spool will not "withstand" the compressive force (FF 259), nor did he explain the inconsistency in his testimony. (Compare FF 259 with FF 253, 275, 285). Mr. Liptak admitted that there are prior art electromagnetic flowmeters in which the housings bear the pipe compression forces. (FF 256).

---

(Footnote continued from page 16)  
design and an undergraduate degree in either mechanical or electrical engineering. (FF 341, 355 Tr. at 2067).

Respondents argue that inventor Schmoock, in testifying in deposition with respect to complainant's K-MAG meter, admitted that he could not in fact say with certainty that any part of the compressive force is transmitted through the spool to the housing because that would depend on the customer's gaskets. (RPFF P 38; RPostR at 11).<sup>4/</sup> Schmoock however did testify that the housing indirectly bears the compressive force. He further admitted that he was not totally familiar with the mechanism of the K-MAG. Schmoock's comments on the effect of customer's gaskets was a guess. (FF 442).

Unrefuted is Prof. Blanco's testimony that while there is no mention of a gasket in the '982 patent, a gasket is a standard method of sealing pressure vessels and therefore there may be a gasket between the pipe flanges and the faces of the flowmeter; and that the compressive force is distributed by means of the gaskets to the housing and the spool. The gasket then would be the primary load transmitting element between the pipe flanges. (FF 211, 213, 215).<sup>5/</sup>

Based on the foregoing the administrative law judge finds that the record establishes that one of ordinary skill in the art, with the '982 patent before him would understand that there is described and claimed in the '982 patent a

---

<sup>4/</sup> It is axiomatic that an inventor need not comprehend the scientific principles on which the practical effectiveness of his invention rests. See e.g. Diamond Rubber Co. v. Consolidated Rubber Co., 220 U.S. 428, 435-36 (1941).

<sup>5/</sup> In the F&P flowmeter because the flanges of the spool are welded to the housing, the load is immediately transmitted to the spool and the housing and hence there is no dependence on the deflection of a gasket. (FF 212). A gasket is seated against the end flanges of the spool. (FF 157).

flangeless electromagnetic flowmeter wherein any applied compressive force is shared by the spool and housing of the flowmeter and also could determine the extent of sharing.

For the foregoing reasons the administrative law judge finds that respondents have not sustained their burden, by clear and convincing evidence, of establishing that the '982 patent is not valid under 35 U.S.C. § 112.

35 U.S.C. § 102

Independent claim 1 and dependent claims 2 through 5 of the '982 patent are in issue in this investigation. (FF 17, Tr. at 664). Respondents' position is that claims 1 through 3 are anticipated by British Sybron patent 1,424,875. (Tr. at 1949). The British Sybron patent was published on February 11, 1976 about a year before inventor Schmoock filed his Ser. No. 771,420 the earliest parent application of Ser. No. 398,809 which resulted in the '982 patent. (FF 16, 77). There is no prior art, alleged to be anticipatory, cited against dependent claims 4 and 5. (Tr. at 1949).<sup>6/</sup>

Respondents have the burden to show, by clear and convincing evidence that all the components of claims 1 through 3 of the '982 patent are found "in

---

<sup>6/</sup> During the prehearing conference complainant stated its willingness to rest its case on claim 5 which is dependent on claims 1 and 2. (Tr. at 101). Claim 5 requires that the cylindrical housing in clause A of independent claim 1 be formed of ferromagnetic material which joins the electromagnet coils to define a magnetic circuit therewith. Claim 2 states that the coils in clause C of claim 1 are disposed in the cavity recited in clause B of claim 1. (FF 17). Respondents would not accept complainant's proposal stating that claim 1 had been asserted by complainant as representative. (Tr. 103). Complainant disagreed. Complainant thereafter withdrew its offer to rest its case on claim 5. (Tr. at 109).

The flowmeters made by complainant under the '982 patent have a ferromagnetic cylindrical housing. (FF 174; *infra* at 55). Claim 1 reads on a flowmeter wherein the housing may be either magnetic or nonmagnetic. (Tr. at 2008).

(Footnote continued to page 20)

exactly the same situation and united in the same way to perform the identical function" in a single reference, viz. the British Sybron patent <sup>7/</sup> and hence are not valid because they are anticipated under 35 USC § 102. Scott v. Inflatable Systems, Inc., 701 F.2d 186, 222 U.S.P.Q. 460,461 (9th Cir. 1983); Railroad Dynamics, Inc. v. A. Stucki Co., 727 F.2d 1506, 1516, 220 U.S.P.Q. 929, 937 (Fed. Cir. 1984); W. L. Gore & Associates, Inc. v. Garlock, Inc., 721 F.2d 1540, 1548, 1554, 220 U.S.P.Q. 303, 309 (Fed. Cir. 1983); In re Certain Automatic Crankpin Grinders, 205 U.S.P.Q. 71, 76 (U.S.I.T.C. 1979); Structural Rubber Products Co. v. Park Rubber Co., 749 F.2d 707, 223 U.S.P.Q. 1264, 1271 (Fed. Cir. 1984); Radio Steel & Mfg. Co. v. MTD Products, Inc., 731 F.2d 840, 845, 221 U.S.P.Q. 657 (Fed. Cir. 1984); Connell v. Sears, Roebuck & Co., 722 F.2d 1542, 220 U.S.P.Q. 193, 198 (Fed. Cir. 1983); SSIH Equipment S.A. v. U.S.I.T.C. 718 F.2d 965, 218 U.S.P.Q. 678, 688 (Fed. Cir. 1983).

Respondents argue that in deposition (RPX-10) complainant's expert Prof. Blanco, agreed that the British Sybron patent does describe a flangeless electromagnetic flowmeter interposable between the end flanges of a pipe

---

(Footnote continued from page 19)

Thus complainant's flowmeters (CPX-21) made under the '982 patent and which have a magnetic housing read on claim 1 as well as claim 5.

<sup>7/</sup> Courts have strictly construed disclosures in foreign publications and patents and restricted their teachings to exactly what they clearly and fully disclose without alteration. Baldwin-Southwark v. Coe, 133 F.2d 359, 55 U.S.P.Q. 398, 407 (D.C. Cir. 1942); Nordberg Mfg. Co. v. Woolery Machine Co., 79 F.2d 685, 687, 27 U.S.P.Q. 189, 191 (7th Cir. 1935); Pursche v. Atlas Scraper & Engineering Co., 300 F.2d 467, 478, 132 U.S.P.Q. 104, 112-113 (9th Cir. 1961); Carson v. American Smelting & Refining Co. 4 F.2d 463, 465 (9th Cir. 1925); Dart Industries, Inc. v. E.I. duPont de Nemours & Co., 348 F. Supp. 1338, 1356, 175 U.S.P.Q. 540, 546, 547 (N.D. Ill. 1972) rev. on other grounds 489 F.2d 1359, 179 U.S.P.Q. 392 (7th Cir. 1973); Carboline Company v. Mobil Oil Corporation, 301 F. Supp. 141, 150, 163 U.S.P.Q. 273, 280 (N.D. Ill. 1969). Respondents' expert Mr. Liptak testified that there is language in the British Sybron patent that is not absolutely clear. (FF 248).



carrying fluid which is to be measured; that the Sybron meter has a cylindrical metal cover which fits within the circle of bolt holes of the pipe flanges; that the Sybron meter also has a non-magnetic spool coaxially disposed within its cover and provided with end flanges which are seated against the pipe flanges, the cover and spool defining an internal cavity; that the Sybron spool has a strength sufficient to withstand the pressure of fluid flowing through it, as well as the compressive force when it is positioned against the pipe flanges; and that it has diametrically-opposed coils and presumably, diametrically-opposed electrodes. (RPost. at 15, 16).

Respondents also argue that the only ground on which Prof. Blanco found the British Sybron patent to differ over the claimed invention of the '982 patent was in the cylindrical metal cover of the Sybron flowmeter which it is said "Prof. Blanco asserted could not be interpreted as a 'housing' since he, as a specialist in the field, interpreted 'housing' as meaning an element which carries a compressive load. (p. 39, l. 11-19)" (RPX-10).<sup>8/</sup>

---

8/ Page 39, l. 11-19 relied (RPX-10) on by respondents (RPost at 16) read:

Q. Would you say that also is a flowmeter that has a housing whose external diameter is smaller than the circle of bolt holes [sic] in the pipeline in which the meter is interposed?

A. I have to disagree there, because there is no housing in this [Sybron] patent.

Q. The interior of the flowmeter is just exposed to the elements; is that your testimony?

A. No. There is a cover; not a housing.

Q. What is the difference between a housing and a cover?

A. The housing maintains stresses and position, and is not just intended as an envelope. It is intended to take stresses. That is a very important difference. (RPost. at 16).

Respondents further argue that the cover in the flowmeter of the British Sybron patent functions in the same way as the cover in the '982 patent in that both protect the respective flowmeter from the environment and to the extent that there is any load sharing between the spool and the housing of the '982 patent, it occurs also in the flowmeter of the British Sybron patent (RPFF 19, 21); that an engineer of ordinary skill would know how to make the spool of the British Sybron patent strong enough for its intended purpose, i.e., to support any compressive load (RPFF 21); and that the spool of the flowmeter of the British Sybron patent is coaxially disposed within the cover or housing and forms a cavity with the housing as specified in claim 1 of the '982 patent. (RPFF 21).

Complainant argues that the cover of the British Sybron patent does not function as a structural element to support the spool against the compressive forces since it is not joined to the spool as that term is used in the '982 patent and that the cover and spool of the flowmeter in the British Sybron patent are not unitary (CPFF 72); that the cover of the British Sybron patent is positioned in grooves located on the inside of the end flanges of the spool and not "joined" to the spool but simply wrapped around it (CPFF 73, 74); that in order to clamp the ends of the thin cover in the flowmeter of the British Sybron patent the short sides are folded back so that a channel strip may be slipped over the short sides to hold the cover on the spool; that the cover does not form a fluid seal (CPFF 75); that the cover of the meter in the British Sybron patent is neither designed nor does it function to support the ceramic spool (CPFF 76); that the embodiment shown in Figure 7 of the British Sybron patent could not withstand the compressive forces needed to effect a seal with the pipe flanges (CPFF 77); that the meter of the British Sybron

patent does not contain a cylindrical metal housing which is joined to the end flanges of the spool to form a unitary flowmeter such that the housing supports the spool against the compressive forces exerted by the pipe flanges; and that, unlike claim 1 of the '982 patent, the spool of the British Sybron patent is not disposed within the cylindrical metal housing but rather is wrapped around and supported by the spool. (CPFF 79).

In order to find whether the British Sybron patent is an anticipatory reference against claims 1 through 3 of the '982 patent, the administrative law judge must determine if respondents have established, by clear and convincing evidence, that the cover of the transducer or flowmeter disclosed in the British Sybron patent <sup>9/</sup>functions as the housing of the flowmeter of the '982 patent. <sup>10/</sup>

The '982 patent discloses a compact and efficient flangeless electromagnetic flowmeter which includes the cylindrical housing and a spool

---

<sup>9/</sup> A transducer is a flowmeter. (FF 179).

<sup>10/</sup> With respect to whether there has ever been a commercial embodiment of a flowmeter described in the British Sybron patent, respondents' expert Mr. Liptak admitted that in his Instrument Engineers' Handbook (1969) (RX-150) and its revised edition (1982) (RPX-3) there is no illustration of a flowmeter disclosed in the Sybron patent although the handbook is intended to illustrate flowmeters in commercial practice. However he testified that the device at page 486 (Fig. 5.8f) of the handbook (1969 edition) is in all respects identical to Figure 1 of the British Sybron patent. (FF 294, 295). It is noted that the handbook was copyrighted in 1969 and the first patent application on the Sybron patent disclosure in the Sybron patent disclosure was not filed until June 19, 1972 when it was filed in the U.S. Patent Office, presumably in the absence of a one year 35 U.S.C. § 102 statutory bar. (FF 77). Also, the Fig. 5.8f is merely a generic arrangement with no details of the arrangement as disclosed in the British Sybron patent. (FF 295). Later when Mr. Liptak was asked whether he was aware of any commercial magnetic flowmeter, prior to the F&P flangeless magnetic flowmeter (CPX-29) made according to the '982 patent (See infra at 52-55), he testified that "I have already answered that I am not aware of any such combination of features which does not exclude the possibility that there were." (FF 296). With respect to domestic corporations; Brooks

(Footnote continued to page 24)

of a relatively large diameter that defines a flow conduit for the fluid to be metered. (FF 27, 29, 31). The spool is coaxially disposed within the housing and, provided with end flanges which are seated against the ends of upstream and downstream pipes, define with said housing an internal cavity. (FF 17). The housing covers the spool completely, the '982 patent disclosing that "[s]urrounding the spool and concentric therewith" is the cylindrical housing. (FF 30, 368). In addition Figures 2 and 3 of the '982 patent show the housing covering the spool completely. (FF 368). The inner surface of the spool is "covered" by an insulating liner. (FF 29). The '982 patent discloses that the housing is joined to the spool and teaches a person of ordinary skill in the art that the compressive force transmitted into the flowmeter unit of the '982 patent is shared, by design, by the spool and the housing of the claimed flowmeter. (supra at 12-18). The housing of the claimed flowmeter of the '982 patent functions as a mechanical support for the meter assembly and a weatherproof enclosure. In addition it can afford a magnetic flux return path for the electromagnets. (FF 36). Hence to find that the British Sybron patent anticipates claims 1 through 3 of the '982 patent, it must be found that respondents, by clear and convincing evidence, has established that the cover, as described in the British Sybron patent, completely surrounds the spool and by design is joined to the spool so that any compressive force transmitted into the flowmeter of the British Sybron patent is deliberately shared by the spool and the housing; and that the cover

---

(Footnote continued from page 23)

Instrument Div. of Emerson Electric Co. presently manufactures a flangeless magnetic flowmeter in addition to complainant. The Brooks' flowmeter does not have a magnetic housing (FF 352, 354). Complainant F&P was the first company to offer for sale a flangeless electromagnetic flowmeter. (FF 356).

functions as a mechanical support for the flowmeter of the British Sybron patent.

In accordance with the invention disclosed in the British Sybron patent there is provided an electromagnetic flowmeter comprising a substantially right circularly cylindrical ceramic tube, the end regions of which are each provided with a flange, each flange being integral with the ceramic tube and extending radially outwards thereof continuously about the periphery of the ceramic tube, spaced electrodes on the inner surface of the ceramic tube, and magnetic field producing elements between the flanges and received within the annular spaces subtended between the peripheries of the flanges and the outer surface of the ceramic tube between the flanges. (FF 79). The text of the British Sybron patent, before describing the embodiments, does not mention the cover. The cover is only described with respect to three embodiments.

The first embodiment (Figures 1, 2 and 3) of the British Sybron patent is for a flowmeter used in the sampling of a liquid flow, as sewage, in a large main. (FF 81). The ceramic tube in this large main sewage embodiment has one flange at each end of the ceramic tube which provides streamlining for the ceramic tube, thereby adapting it to be inserted directly into a fluid flow having a cross-section much greater than that of the ceramic tube. (FF 80). In this large main sewage embodiment the flowmeter is not subjected to a compressive force (FF 301) which is contra to the operation of the flowmeter unit of the '982 patent which is subjected to a compressive force. In this large main sewage embodiment, the meter is dropped inside a manhole using a support means. (FF 187, 363).

The structure of the flowmeter of the large main sewage embodiment of the British Sybron patent has generally the form of a right circularly cylindrical tube having a right circularly cylindrical bore and streamlined ends. Said

flowmeter comprises a ceramic flow tube and a stainless steel cover. The ceramic flow tube has its ends flared to define flanges at each end integral with the right cylindrical part containing the cylindrical bore. The flanges flare radially outwardly in a generally smooth curve for about ninety degrees to provide the streamlining. The trailing edges of the flanges are, in effect, undercut by grooves to define ledges. The grooves and ledges are annular in form, and extend all the way around the main cylindrical part of the tube. (FF 82).

The grooves defined by the flanges in the large main sewage embodiment of the British Sybron patent receive the long edges of the rectangular stainless steel strip or cover, the width of which is the distance "between the grooves" and the length of which is the circumference of the ceramic tube. The phrase "between the grooves" is not defined. Hence the exact width is undefined. The strip or cover may be wrapped around the ceramic tube, with its long edges sealed in the grooves so that the strip's short edges meet and can be welded together. The junctures of the long edges and the grooves are preferably sealed by any suitable means in order to keep the flowing material in the sewage main from getting into the annular space between the flanges, the inside of the strip or cover and the cylindrical part of the ceramic tube. (FF 82).<sup>11/</sup>

---

<sup>11/</sup> The first embodiment flowmeter of the British Sybron patent is similar to a "Pitot" type magnetic flowmeter. Respondents' expert Mr. Liptak testified that in the Pitot arrangement the inner and outer surfaces of the flowmeter elements are exposed to the same pressure which is contrary to the use of the flowmeter claimed in the '982 patent. (FF 301). In the Pitot flowmeter arrangement the flowmeter samples the flow velocity of a fluid in large rectangular, circular, or irregularly shaped pipes or conduits. A small size magnetic flowmeter is suspended in the flow stream of the fluid to be (Footnote continued to page 27)

The second embodiment of the flowmeter disclosed in the British Sybron patent, illustrated in Figures 4, 5 and 6, is said to be used in a pipeline as is the flowmeter of the '982 patent. This second embodiment comprises a ceramic tube with a bore for receiving the liquid to be measured, a pair of flanges, a pair of annular grooves and a strip or cover of stainless steel seated in the grooves which cover, respondents argue, functions as the housing of the flowmeter of the '982 patent. In the second embodiment a second pair of flanges are provided, preferably being grooved, so that elastomeric annular cushions can be cast or stretched over said second pair of flanges for coupling the flowmeter in a pipe line to measure the flow of a liquid in the pipe. (FF 83). The strip or cover can have its short sides folded back in order that a channeled strip may slip over these short sides to clamp the strip into cylindrical form. In this second embodiment, which discloses the flowmeter for use in a pipe line, the British Sybron patent discloses that a fluid-tight seal between the strip or cover and the tube with the bore is "not necessary" since the flowmeter is not designed to be inserted bodily into a flow of larger cross-section (i.e. as is the Figure 1 embodiment) than the flow in the flowmeter. (FF 83).

The third flowmeter embodiment of the British Sybron patent is a Figure 7 embodiment which is a side elevation of the form of the Sybron invention shown in Figure 1 but modified for use in a pipeline. (FF 81). Elastomeric gaskets

---

(Footnote continued from page 26)

measured. The short length of the meter body and the streamlined configuration are designed to minimize the difference of flow velocity through the meter and the velocity of the fluid passing around the meter. The velocity measurement of the liquid through the meter is representative of the pipe velocity. In the "Pitot" type magnetic flowmeter the magnet coils are, and should be, completely encapsulated in a liner material so that the magnetic flowmeter can be submerged in the liquid to be measured. (FF 295).

are provided which cushion the compressive forces of the pipe flanges, said to be typically metal, on the ceramic ends of the flowmeter. (FF 87). End flanges of pipe sections for use with the flowmeter have a predetermined diameter and a circle of bolt holes. The bolts pull the flanges together to provide a clamping force necessary to seal the flowmeter into the pipeline and encage the flowmeter. (FF 88). In the Figure 7 embodiment a flangeless electromagnetic flowmeter is interposed in a pipeline through which fluid flows. The flangeless electromagnetic flowmeter is encaged within the bolts that extend outside the flowmeter. The non-magnetic ceramic tube of Figure 3 is used in the Figure 7 embodiment. In the Figure 7 embodiment there is a cylindrical metal cover. The cover has an external diameter which is smaller than the circle of bolt holes and the cover lies within the circle of bolt holes. The bolts subject the meter to a compressive force. The spool in the Figure 7 embodiment is provided with flanges which are seated against the ends of the upstream and downstream pipes. The spool defines with the cover an internal cavity and the spool forms a fluid conduit having a longitudinal flow axis. (FF 188).

The electromagnetic flowmeter of the Figure 7 embodiment has a pair of electromagnetic coils that are disposed at diametrically opposite sides of the spool and the coils function to create a magnetic field whose lines of flux extend across the conduit. The coils lie on a coil axis which is normal to the flow axis. The flangeless electromagnetic flowmeter of Figure 7 has a pair of electrodes mounted on the spool at diametrically opposed positions along an electrode axis that is perpendicular both to the coil axis and to the flow axis. The operation of the electrodes is such that when the fluid flows through the conduit it intersects the lines of flux and a signal is induced in the electrodes which is a function of the flow rate. In the Figure 3 and 7



embodiments of the British Sybron patent a cavity is formed between the cover and the ceramic tube. The electromagnetic coils are disposed in the cavity. (FF 193, 194).

Claim 3 of the British Sybron patent specifies that the annular space subtended between the peripheries of the flanges and the outer surface of the tube between the flanges is covered by a cylindrical cover seated on the peripheries of the flanges and extending from one flange to the other flange and all the way around said peripheries. (FF 89). Claim 6 recites that each of the second pair of flanges, which are in the Figure 4 embodiment, has an elastomer cover fitting flush to, and entirely covering, the surface thereof external to the inside of the tube. (FF 89).

Prof. Blanco testified that while the cover of the flowmeter of the British Sybron patent may take some compressive force under some conditions the force would be extremely minor because the cover is described in the Sybron patent as a thin strip of stainless steel. Hence if too much load is placed on a thin strip of stainless steel the strip would eventually collapse or buckle. (FF 227, 228, 232). According to Prof. Blanco the cover of the flowmeter, as disclosed in the British Sybron patent, is not intended to take any compressive force nor to be a structural element but rather is merely for protection from the outside. (FF 178). In support he referred, in the British Sybron patent, to language which states that the grooves receive the long edges of the strip (which meant to Prof. Blanco that the cover fits in grooves around the inner edge of the flanges of the ceramic tube), to language which indicates that the cover is being folded almost like a sheet of cardboard and to language which states that the cover is seated on peripheries (which meant to Prof. Blanco that the cover is laying or supported by little grooves). (FF 228, 229). It is Prof. Blanco's opinion that a cover is not a structural

component; that the cover in the British Sybron patent merely shields the disclosed flowmeter (FF 180); and that because the cover in the British Sybron patent is described as merely attached to or wrapped around the spool, the cover is supported by the spool. In contrast he testified that the housing in the flowmeter of the '982 patent, as illustrated by the F&P Type 10 D 1475 3 inch MINI-MAG flowmeter, supports the spool and the spool is positioned and reinforced by the housing. (FF 182). In addition, while the British Sybron patent states that the ceramic tube is fabricated out of porcelain, just as large ceramic insulators are made, and that this ceramic tube is mechanically quite strong (FF 86, 87), Prof. Blanco testified that ceramic can be brittle and a ceramic tube strong enough to take compressive forces in pipe line application would have to be bulky. (FF 189, 190, 191). (See also testimony of complainant's Mr. Riester to the effect that any thickening of the spool would cause the cavity available for the coils to become smaller. (FF 371)).

Respondents' expert Mr. Liptak also testified that the thickness of the ceramic tube would be a factor in making the ceramic tube of the British Sybron device stand up to compressive force in the low thousands and high hundreds pounds. (FF 250). However he later testified that a typical flowmeter installation could have a compressive force as high as 10,000 pounds. (FF 270).

The administrative law judge finds nothing in the record to conclusively establish that receipt of the longitudinal edges of the cover by the grooves (FF 82) or the folding of the cover (FF 83) or the seating of the cylindrical cover on the peripheries of the flanges, as disclosed in the British Sybron patent (FF 89, claim 3), necessarily establishes a joining of the parts such that in the design of the flowmeters, disclosed in the British Sybron patent, an applied compressive force would be transferred from the spool to the cover

and the cover would act as a structural element of the flowmeter. In fact the word "join", in connection with the recited "cover" and "ceramic tube", is not even used in the British Sybron patent. The British Sybron patent does not state one way or the other way whether or not the end faces of the cover butt against the inner end faces of the ceramic tube. (FF 195). It is not disclosed that the cover is welded to the spool, as in F&P's MINI-MAG (CPC-21) or press-fitted to the ceramic tube as in Krohne's alleged infringing flowmeter. (CPX-23).

Mr. Liptak testified that certain language of the British Sybron patent teaches that the cover in Figure 3 of that patent is in physical contact with both the horizontal surfaces and the vertical sections of the grooves of the ceramic tube. (FF 251). Mr. Liptak did not explain how the language "the width of which is the distance between the grooves" and "cover seated on the peripheries of the flanges" (FF 246, 251) necessarily means that cover is in physical contact with the vertical surfaces of the grooves.

Uncontradicted is Prof. Blanco's testimony that the stainless steel strip or cover in the British Sybron flowmeter would buckle or collapse when too much compressive force is shared by the the strip or cover. (FF 227). While Mr. Liptak testified that ceramics are extremely strong in compression (FF 262), he also testified that ceramic is a brittle material that cannot be subjected to an extensive amount of tensile force without breaking; that ceramic is weak to bending forces (FF 882); that theoretically a fluid exerting a radial force of up to 600 pounds per square inch would have the tendency of causing a ceramic flow tube to bulge outwardly (FF 283); that if forces exceed the ability of a ceramic tube to retain its shape so that internal forces cause it to bulge the material comes into tension and in tension ceramic is weak (FF 284); and that the housing, on either the Krohne

CPX-23 flowmeter or the R&P CPX-34 flowmeter, would tend to prevent breakage of the ceramic spool in a condition where the pipe flanges are skewed. (FF 285). A flangeless flowmeter can be subjected to various forces produced by a customer's piping. (FF 361).

Moreover there is the specific disclosure in the British Sybron patent, for an embodiment intended for use in a pipe line, that:

This cross-sectional view of Figure 6 and also Fig. 5 [British Sybron Figures 4, 5 and 6 are to a flowmeter embodiment for coupling in a pipe line (FF 83)] show how the strip 126 has its short sides folded back in order that a channeled strip 33 may slip over these short sides in order to clamp the strip 126 into cylindrical form. In this instance, a fluid-tight seal between the strip 126 and the tube 109 is not necessary, since the transducer is not designed to be inserted bodily into a flow of larger cross-section than the transducer. (Emphasis added). (FF 83).

The administrative law judge has taken note that in April 1985 respondents admitted that the British Sybron patent shows an electromagnetic flowmeter which does not have a cylindrical metal housing subjected to a compressive force effecting a fluid seal. (FF 439). Moreover respondents' expert Mr. Liptak testified that the above language of the British Sybron patent describes a sheet metal operation and that the housing of F&P's flowmeter CPX-29, constructed under the '982 patent (infra at 52-55), does not represent a sheet metal type configuration (Tr. 308, 310); and that while Figure 6 of the Sybron patent shows a cross batching for the cover 126 (FF 243), the cover can be bent around. (FF 307). Also while Mr. Liptak stated that the language in the British Sybron patent, viz "[i]n this instance, a fluid-tight seal between the strip 126 and the tube 109 is not necessary, since the transducer is not designed to be inserted bodily into a flow of larger cross-section than the transducer", does not "necessarily" describe the British Sybron Figure 7 pipeline flowmeter, he admitted that the

British Sybron Figure 7 embodiment is not designed to be inserted bodily into a flow of larger cross-section than the flowmeter tube. (Tr. 309). It is only when a flowmeter is inserted into a flow of larger cross section, as in the large sewage main embodiment, that the British Sybron patent teaches a fluid-tight seal between the cover and the flow tube.

As did Prof. Blanco testify, Mr. Liptak testified that the Sybron patent teaches him that the cover is only for environmental protection. (FF 178, 306). In contrast the '982 patent specifically discloses that the housing provides for mechanical support in addition to affording a weatherproof enclosure. (FF 36). If the cover was removed from the flowmeter of the British Sybron patent the flowmeter could still operate as it did with the cover. If the housing of the claimed '982 flowmeter is removed, the operation of the flowmeter would be affected because the housing in the claimed flowmeter is a structural element of the flowmeter. (FF 178, 180, 182, 230, 233, 236, 237).

In addition the '982 patent discloses that the non-magnetic spool is coaxially disposed "within said housing" (FF 17) and that surrounding the lined metal spool and "concentric therewith" is the housing. (FF 30, 33). The Figures of the '982 patent, particularly Figures 2 and 3, support this language. (FF 31, 368). The record does not establish that the British Sybron patent discloses that the ceramic tube is within the cover or that surrounding the ceramic tube and concentric therewith is the cover. Rather the record is to the contrary. (FF 82, 83).

During the hearing respondents made reference to dictionary definitions for the proposition that the term "housing" refers to a protecting means. (FF 202, 204). Also reference was made to an F&P catalogue for the same proposition. (FF 203). It was argued that the housing in the '982 patent

functions as a protecting means as does the cover in the British Sybron patent and hence the word "housing" should be equated to the word "cover" as "cover" is used in the British Sybron patent.

Inventor Schmoock in the '982 specification did not limit the word "housing" to a function affording only a weather proof enclosure. Thus he specifically stated that the housing of the flowmeter claimed in the '982 patent affords mechanical support. (FF 36). It is well settled that a patent applicant may be his own lexicographer. W. L. Gore & Associates, Inc. v. Garlock, Inc. supra 220 U.S.P.Q. at 316 (Fed. Cir. 1983). Moreover even respondents' expert Mr. Liptak testified that a housing in addition to providing environmental protection can, as in certain prior art electromagnetic flowmeters, bear a compressive force. (FF 256).<sup>12/</sup>

Respondent Krohne has used the term "housing", not "cover" in its own documents when describing the allegedly infringing X-1000. Thus a Krohne internal report dated November 28, 1980 stated "[r]ound metal housing also to be employed as a magnetic back connection (as has been conventional for many years already with our large Model 63 and 960 generators). The housing should if at all possible be below the connecting bolts." (FF 327). A Krohne house publication stated:

In order to protect the aluminum oxide spool from external damage, it is shrunk into a steel cast housing whereby the spool and housing are intimately connected. (FF 328).

A Krohne advertisement states that the aluminum oxide measuring section is press-fitted into a metal housing and the metal housing gives the best

---

<sup>12/</sup> Dictionary definitions do not limit the term "housing" to a protecting  
(Footnote continued to page 35)

protection against external electrical, magnetic and mechanical interference.  
(FF 329).

In addition to complainant and respondents, the Foxboro Company has used the term "housing", not "cover", in describing elements of its flowmeters. Thus a 1975 Foxboro United States patent, referenced by respondents' expert Mr. Liptak (FF 243), states that a conventional method for aligning flow devices between flanges requires that the device be mounted in a housing having flanges. (FF 330).

For the foregoing reasons the administrative law judge finds that respondents have not shown, by clear and convincing evidence, that the "cover" in the British Sybron patent functions as the "housing" in the '982 patent, i.e. that the "cover" of the flowmeter in the British Sybron patent performs the identical functions as the "housing" of the flowmeter in the '982 patent. Accordingly he finds that respondents have not met their burden in establishing that claims 1 through 3 of the '982 patent are anticipated under 35 U.S.C. § 101 by the British Sybron patent.

35 U.S.C. § 103

Respondents argue that claims 4 and 5 and, in the alternative, claims 1 through 3 of the '982 patent are not valid because the differences between the subject matter sought to be patented and the British Sybron patent are such that the subject matter as a whole would have been obvious at the time the

---

(Footnote continued from page 34)  
function. Thus Webster's Seventh New Collegiate Dictionary (1965) for "housing" includes the definition "a frame or other support for mechanical parts" in addition to the definition "something that covers or protects."  
(FF 203).

invention was made to a person having ordinary skill in the art to which said subject matter pertains, i.e. a person having five-ten years experience in flowmeter design and an undergraduate degree in either mechanical or electrical engineering. (FF 341, 355, Tr. at 1949, 2067).

Again respondents bear the burden of proving, by clear and convincing evidence, that claims 1 through 5 of the '982 patent are not valid because the subject matter claimed is obvious. Perkin-Elmer Corp. v. Computervision Corp. 732 F.2d 888, 894, 221 U.S.P.Q. 669 (Fed. Cir. 1984); In re Certain Surveying Devices, 208 U.S.P.Q. 36, 42-43 (USITC 1980).

Respondents argue that the '982 claims are to flangeless flowmeters and that flangeless flowmeters are old in the art. It is argued that the prior art includes a wide variety of flowmeters with which those of ordinary skill in the art could be expected to be familiar. These are said to be target meters, orifice meters and vortex shedding meters all of which have been offered in wafer-type (i.e. "flangeless") form long before 1975.<sup>13/</sup> Typical of such meters is said to be a target meter patented by Foxboro in 1975. (RPostR. at 6). Another specific meter of the prior art was said to be found in a Kettelsen German Patent.

Respondents argue that flowmeters having saddle-shaped coils inside the meter body and a ferromagnetic housing material, which serves as the magnetic

---

<sup>13/</sup> Respondents' expert Mr. Liptak preferred the term "wafer" to "flangeless." because if the flanges of prior art flowmeters, e.g. CPX-22, are removed there remains flanges of the flowmeters. (FF 240). While the housing of the claimed flowmeters of the '982 patent is flangeless, the spool has flanges. (FF 29). By "wafer-type" flowmeters Mr. Liptak intends an electromagnetic flowmeter which is inserted between pipe flanges in a bird-cage type arrangement. (FF 239). Complainant's Mr. Reister's definition of a flangeless magnetic flowmeter is a metering device which is interposed between customer flanges. The flangeless meters do not have flanges that have to be mated with customers' flanges. The flangeless meters have to be

(Footnote continued to page 37)



return path, as in the claimed flowmeter of the '982 patent, are shown in Fig. 5.8c of the 1969 Instrument Engineer's Handbook which shows complainant's short-form flowmeter (RPostR. at 7). Hence it is argued that claims 1 through 5 are obvious under 35 U.S.C. § 103 when the Sybron British patent is taken in conjunction with prior art as exemplified by complainant's short form flowmeter and the target meter. (RPostR at 8).

Complainant argues that none of the prior art references relied upon by respondents teaches or suggests a flangeless flowmeter which utilizes the housing, as a structurally supportive member, to support the unit against the compressive forces applied by the pipe flanges (CPFF 89); that none of the prior art references relied upon by respondents suggests the use of a ferromagnetic housing as a magnetic return path in the context of a flangeless electromagnetic meter (CPFF 90); and that none of the prior art references relied upon by respondents disclose a spool-shaped flow tube whose end flanges are "joined" to and, therefore, are unitary with the housing which together share the compressive and any bending forces. (CPFF 91).

(a) Prior Art

In interpreting 35 U.S.C. § 103 the Supreme Court, in the historic case of Graham v. John Deere Co., 383 U.S. 1, 17-18, 148 USPQ 454, 467 (1966), stated:

Under § 103, the scope and content of the prior art are to be determined; differences between the prior art and the claims at issue are to be ascertained; and the level of ordinary skill in the pertinent art

---

(Footnote continued from page 36)  
supported by the customers' pipe flanges. (FF 346) Krohne advertises that the allegedly infringing flowmeters can be fitted between standard pipe flanges. (FF 329). The term "flangeless flowmeters" is used by the Foxboro Company. (FF 330).

resolved. Against this background, the obviousness or nonobviousness of the subject matter is determined.

Inventor Schmoock was not attempting to patent in his '982 patent merely the concept of the magnetic flowmeter. He recognized that the magnetic flowmeter had achieved a distinct place in the flowmeter art stating that magnetic flowmeters, such as those disclosed in U.S. Pat. No. 3,695,104, No. 3,824,856. No. 3,783,687 and No. 3,965,738, are especially adapted to measure the volumetric flow rates of fluids which present difficult handling problems, such as corrosive acids, sewage and slurries and that because the magnetic flowmeter is free of flow obstructions, it does not tend to plug. (FF 20). Respondents' expert Mr. Liptak in his Handbook recognized certain advantages in magnetic flowmeters. (FF 320).

The record establishes that each of the components of the flowmeter of claims 1-5 of the '982 patent is in the prior art. Thus prior to the Schmoock invention of the '982 patent, magnetic flowmeters were known (FF 20, 101); flangeless flowmeters were known (FF 193, 194); flowmeters wherein the housing is formed of ferromagnetic material which joins electromagnet coils to define a magnetic circuit were known (FF 218); coils conforming to the curvature of the housing were known (FF 101); saddle-shaped coils for use in magnetic flowmeters were known (FF 218); coils disposed in a cavity of a magnetic flowmeter were known (FF 194); and ceramic flow tubes in magnetic flowmeters were known. (FF 79). It is immaterial however that the claimed subject matter involves a combination of old components. The Federal Circuit has made it clear that there is not a different patentability standard for a "combination" patent. Medtronic Inc. v. Cardiac Pacemakers Inc. 721 F.2d 1563, 1566, 220 U.S.P.Q. 97, 100 (Fed. Cir. 1983). In other words the fact that each of the components, as such, is in the prior art does not negate

patentability. The issue is whether respondents have established, by clear and convincing evidence, that the combination of the teachings of the British Sybron patent, the 1969 description of complainant's "short form" magnetic flowmeter, the Foxboro flangeless flowmeter in a 1975 patent and/or the flowmeter of a Kettelsen German patent suggests to a person of ordinary skill, confronted with making a highly compact magnetic flowmeter interposable between the end flanges of the upstream and downstream pipes of a line conducting fluid whose flow rate is to be metered, the end flanges of the pipes having a predetermined diameter and a circle of bolt holes, a structurally integrated flangeless electromagnetic flowmeter unit comprising (1) a ferromagnetic or nonferromagnetic cylindrical metal housing providing mechanical support and having an external diameter which is smaller than that of the circle, whereby when the unit is interposed between the end flanges of the pipes, the housing lies within the circle with the pipe flanges and bridged bolts passing through the holes to engage the unit and subject it to a compressive force effecting a fluid seal; and (2) a non-magnetic spool coaxially disposed within said housing, and provided with end flanges which are seated against the ends of the upstream and downstream pipes and defining with said housing an internal cavity, said spool forming a fluid conduit having a longitudinal flow axis which joins the upstream and downstream pipes, said spool having a strength sufficient to withstand the pressure of fluid flowing in the conduit and said compressive force, and said spool working together with said housing to share loads and to provide for the proper function of the flowmeter unit. (FF 17, 139, 140).

Obviousness cannot be established by combining the teachings of the prior art to produce the claimed invention, absent some teaching or suggestion in the prior art supporting the combination. There has to be something present

in the prior art teachings to suggest to one skilled in the art that the claimed invention in issue would have been obvious. W. L. Gore & Associates, Inc. v. Garlock, Inc., supra 220 U.S.P.Q. at 314 (Fed. Cir. 1983).

The components of complainant's flowmeter, viz. flangeless cylindrical metal housing, non-magnetic spool, pair of electromagnetic coils and pair of electrodes, claimed in the '982 patent are integrated to form a highly compact flowmeter unit.<sup>14/</sup> (FF 17, 19). The patented flowmeter can be readily installed in a flow line between the flanged ends of upstream and downstream pipes (FF 19) in the same manner as the allegedly infringing flowmeters are advertised by Krohne to be fitted between standard pipeline flanges. (FF 329). Thus a flangeless flowmeter offers the customer the opportunity to interpose the flangeless flowmeter between foreign or alien flanges. (FF 347). In complainant's flangeless 3 inch flowmeter made under the '982 patent (infra at 52-55) the bolts engage the housing such the metering section is automatically centered because of the clearance between the bolts and housing. (FF 348). A flangeless design has made magnetic flowmeters more competitive in the market relative to the other types of flow metering

---

<sup>14/</sup> The word "compact" is a relative term and its use is not restricted to the '982 patent. The word "compact" (FF 333) has been used to refer to the previous state of the art and to suggest that the particular device in question is smaller in some or all of its dimensions relative to its predecessor. (FF 273). The '982 patent describes a compact flangeless electromagnetic flowmeter (FF 17, 23) the largest of which can be represented by the 4" MINI-MAG. (FF 5). The smallest representative prior art electromagnetic flowmeter was complainant's 6" flanged Model 10D1435A/U Mag-X (COPA-X). The Model 10D1435A/U Mag-X is a flanged volumetric liquid flow rate measurement device which incorporates complainant's original "short-form" encapsulated design described in the 1969 Handbook plus an added electronic principle. (FF 273, 333). Compactness can be an important consideration in purchasing flowmeters. (FF 524, 532).

devices. (FF 539). When flangeless flowmeters are used the type of flanges on the pipe are not critical. (FF 516).

Complainant's "short form" magnetic flowmeter shown in a 1969 Handbook, relied on by respondents, is said to be "much shorter in length and, therefore, much lower in weight" than an earlier design. (FF 101). Hence as early as 1969 there was the desire in the flowmeter art to reduce the existing size of magnetic flowmeters. In 1970 a typical commercial electromagnetic flowmeter was 13.9 inches long and weighed 77 pounds. (FF 418). In the prior art various factors have contributed to the compactness of flowmeters e.g. shape and type of coil, use of pulsed DC field electronics. (FF 273, 395, 533, 534, 535). Krohne however sells a "compact" flanged flowmeter with AC electronics using a flow tube of stainless steel with a liner of neoprene. (FF 537). Reduction of the volume of flowmeters through a flangeless magnetic flowmeter was the subject of discussions at Krohne as early as 1965. (FF 441(b), 553(a)).

In complainant's "short form" 1969 magnetic flowmeter the magnet coils are located inside the meter body. The meter body is of magnetic material and performs the function of the iron core pieces required as a separate component in "earlier designs." The coils are potted and a lining is inserted to isolate the coil windings from the process fluid. The placing of the magnetic coils within the meter body is said to reduce the required size of the coils and to result in less current consumption. (FF 101).

Complainant's 1969 "short form" magnetic flowmeter has flanges on the meter body. (FF 184). The meter body is of magnetic material and performs the function of iron core pieces required as a separate component in earlier designs. Within the meter body is an insulating liner that carries the flowing liquid to be measured. The flanges of the flowmeter are bolted to pipe flanges. (FF 102). These flanges extend outwardly from the housing and mate to the inside of pipe flanges. In the short form flowmeter if the internal

part of the meter, i.e. the potting compound fails, the coils in the flowmeter are exposed directly to the customer's fluid because there is no intervening spool. In the '982 claimed flowmeter there is an intervening spool which is a barrier to the fluid of the customer and the rest of the parts of the flowmeter. (FF 359).

Because the "short-form" meter is a flanged flowmeter there are no forces in the center of the flowmeter unit because the two flanges on the housing of the 1969 "short-form" flowmeter are attached to the inside of the two pipe flanges. (FF 184). The only stresses in the center of the 1969 flowmeter might be bending stresses but not compressive stresses. (FF 184). The compressive forces are between the flanges of the pipe and the flanges of the flowmeter. (FF 184). The claimed flowmeter of the '982 patent has no flanges bolted to pipe flanges. (FF 17). As respondents' expert Mr. Liptak testified the description of complainant's 1969 "short form" flowmeter does not show a spool-shaped tube in any housing, does not show a flangeless or wafer-type configuration and does not teach to a person of ordinary skill in the art to use a spool-shaped tube in combination with a flangeless housing. (FF 298). An insulating liner shown in the 1969 "short-form" flowmeter is not a spool. (FF 298). There is nothing in the 1969 description of the "short-form" flowmeter to suggest placing a spool in the housing of the 1969 flowmeter to form a combined unit. (FF 184).<sup>15/</sup>

---

<sup>15/</sup> The 1969 "short-form" magnetic flowmeter was before the United States patent examiner during the prosecution of the application that led to the '982 patent. (FF 50, 298).

The record establishes nothing in the British Sybron patent that would suggest to one of ordinary skill in the art in the 1970s substituting the magnetic flanged body of the "short form" flowmeter for the cover. (FF 177). The British Sybron patent discloses that the cover is stainless steel. (FF 82, 83). It is intended to provide only environmental protection. (FF 178, 306). Stainless steels, including the most common ones, are generally not magnetic. They are used for decorative or for other sheet metal operations. A sheet metal stainless steel would not be able to support a magnetic circuit and accordingly the British Sybron patent teaches away from any need for a magnetic housing. (FF 177). There is nothing in the British Sybron patent to suggest substituting the magnetic meter body of the Handbook for the non-magnetic stainless steel cover. Moreover assuming a suggestion, because the short form meter body has flanges, the resulting flowmeter would be a flanged flowmeter, not a flangeless flowmeter as claimed in the '982 patent.

In addition because the cover in the British patent is intended to produce only environmental protection, (FF 178, 306) there is nothing in the British Sybron patent to suggest substituting the cover with a housing such that the housing is joined to the ceramic spool and any applied compressive force is shared by the spool and housing.

Respondents rely also on a 1975 patent assigned to Foxboro. (FF 243, 230). While this patent discloses a flangeless flowmeter it is not a magnetic flowmeter which occupy a distinct position in the flowmeter art. (FF 320). There is also no suggestion in the Foxboro patent that a spool be placed in a housing to form a combined unit. There is nothing in either the British Sybron patent or the Foxboro patent that suggests substituting the flangeless

housing of the Foxboro patent for the cover of the British Sybron patent such that there is a sharing of applied compressive force between the housing and spool.

Respondents also cite a Kettelsen German patent 2,040,682 obtained by complainant's German affiliate. (FF 90). This patent was before the United States patent examiner during the prosecution of the application that led to the '982 patent. (FF 50). While the German patent discloses a flangeless magnetic flowmeter, it also taught the need for complicated laminations of strapping for an efficient magnetic return path. (FF 361, 362).<sup>16/</sup> Moreover the flangeless magnetic flowmeter of the German patent comprising a tube of insulating synthetic resin through which flowed the medium to be measured had no external housing. The flangeless magnetic flowmeter of the German patent was never commercialized because the meter, when subjected to compressive and twisting forces, cracked and broke. (FF 361, 362). In view of the absence of a housing of any kind and the teaching that complicated laminations of strapping are necessary for an efficient magnetic return path in the German patent it is not seen how its combination with the British Sybron patent suggests the claimed flowmeters of the '982 patent.

A fact that a patentee proceeded contrary to accepted wisdom of the prior art is strong evidence of nonobviousness. United States v. Adams, 383 U.S. 39, 148 U.S.P.Q. 479, 483 (1966); W.L. Gore & Associates Inc. v. Garlock, Inc. supra, 220 U.S.P.Q. at 312. There is testimony from respondents' expert Mr. Liptak that it would be bad engineering design to put compressive forces on a housing intentionally. (FF 257, 261). Complainant's Riester testified that in the mid 1970's workers in the art were not aware of any commercial

---

<sup>16/</sup> Straps of magnetic material have to be of sufficient weight either by thickness or length to keep the magnetic flux within its confines. Also any wiggle of the straps can change the performance of a meter. (FF 351).



flangeless meters capable of withstanding high compressive forces and that they believed that to have an efficient magnetic return path, complicated laminations of strapping were required. (FF 342). Inventor Schmoock, by intentionally joining the housing and spool and with the spool coaxially disposed within the housing i.e. the housing surrounding the spool and concentric with the spool (FF 17, 30), caused applied compressive force to be shared by the housing.

In addition, respondents in 1976 filed a utility model application for a magnetic flowmeter. This flowmeter was flanged not flangeless. The flanges on the meter made it possible to connect the meter to an existing pipeline. The meter did not include a ferromagnetic housing but rather used magnetic straps. The meter was initially designed not to include flanges. However because of customer concern with possible corrosion in the bolts extending through the meter body, the meter was redesigned to incorporate flanged ends through which the bolts passed. (FF 419, 422).

Also as late as Nov. 1980, after Schmoock's continuation-in part Ser. No. 174,609 was filed on August 1, 1980 in the United States Patent Office (the application, on which the '82 patent is based, is a divisional application of Ser. No. 174,609 (FF 16)), respondents in considering the design of their allegedly infringing X-1000 flowmeter, stated "unflanged if at all possible." The same uncertainty was expressed by Krohne on March 17, 1981. (FF 323, 325). By that time it appears that Krohne was aware of the F&P claimed flangeless electromagnetic flowmeter. (FF 325).

(b) Secondary Considerations

The Supreme Court has detailed factual considerations which tribunals must apply in determining the question of obviousness in Graham v. John Deere Co., supra, 383 U.S. at 18, 148 U.S.P.Q. at 467:

Such secondary considerations as commercial success, long felt but unresolved needs, failures of others, etc., might be utilized to give light to the circumstances surrounding the origin of the subject matter sought to be patented. As indicia of obviousness or nonobviousness, these inquiries may have relevancy.

The Federal Circuit referred to secondary consideration as "objective indicia of non-obviousness" and elevated them to the status of a fourth factual inquiry mandated by Graham. Jones v. Hardy, 727 F.2d 1524, 1530, 1531, 220 U.S.P.Q. 1021, 1020 (Fed. Cir. 1984), Rosemount, Inc. v. Beckman Insts., Inc., 727 F.2d 1540, 1546, 221 U.S.P.Q. at 1 (Fed. Cir. 1984). The so-called "secondary considerations", such as long felt need, commercial success, expressions of disbelief by experts etc. should be considered in every case for whatever probative value they have and are not to be limited to cases where patentability is a "close" question. Stratoflex, Inc. v. Aeroquip Corp. 713 F.2d 1530, 218 U.S.P.Q. 871, 879 (Fed. Cir. 1983) Vandenberg v. Dairy Equipment Co. 740 F.2d 1560, 1568-69, 224 U.S.P.Q. 195, 198-199 (Fed. Cir. 1984).

Respondents' expert Mr. Liptak testified that a meter that can be made small, lighter and shorter coaxially is a meter which is more compact in size. (FF 288). In the claimed flowmeter of the '982 patent compactness has been obtained through the use of the housing as a return magnetic path (FF 216), use of the housing as a load sharing element (FF 207, -217), the flangeless aspect of the flowmeter and the shape of the coils. (FF 217). There has been a need for compact electromagnetic flowmeters as shown by respondents' evolution of their 2 inch size magnetic flowmeters. In 1970 there was introduced model MID51C flanged electromagnetic flowmeter of weight 77 pounds and dimensions 13.8" long by 9.1" wide by 15.4 " high. (FF 518).<sup>17/</sup> In 1982 with Krohne's introduction of the allegedly infringing

---

<sup>17/</sup> Large size electromagnetic flowmeters often required lifting hooks for moving the meters. (FF 359).

flangeless X-1000 the weight had been decreased to 9 pounds and the dimensions to 4.1" long by 4.0" wide by 8.6" high. (FF 418). It has not been controverted that the flangeless electromagnetic flowmeters, e.g. F&P CPX-29 made according to the '982 patent, is more compact than the prior art representative Mag 10 D 1435. (FF 273). Size of an electromagnetic flowmeter has been considered important in the industry. (FF 443).

The F&P flowmeter manufactured under the '982 patent has enjoyed commercial success. Thus complainant's introduction of the MINI-MAG and K-MAG led to an improvement in F&P's unit sales of magnetic flowmeters having a conduit diameter of two to four inches over F&P's prior models in the same size range. (FF 513). A flanged flowmeter of a given flow tube internal diameter has a higher cost and market price than a flangeless magnetic flowmeter having the same flow tube inside diameter. (FF 541).

Prior to the '982 patented electromagnetic flangeless flowmeter there were unsuccessful attempts to produce flangeless electromagnetic flowmeters. (FF 361, 419, 422). In fact the record establishes that the patented '982 flowmeter is the first commercial electromagnetic flangeless flowmeter.<sup>18/</sup>

Finally the record shows disbelief about the patented invention. (FF 257, 261).

For the foregoing reasons the administrative law judge finds that respondents have not established, by clear and convincing evidence, that the '982 patent is not valid under 35 U.S.C. § 103.

#### B. Infringement of the '982 Patent

Complainant has the burden, by a preponderance of evidence, of proving that the respondents' ALTOFLUX X-1000 and DELTAFLUX magnetic flowmeters in conduit diameter sizes 2 inch and above infringe claims 1 through 5 of the

---

<sup>18/</sup> See footnote 10 at 23 of opinion.

'82 patent and in size less than 2 inch conduit diameter infringe claims 1, 2 and 5 of the '82 patent. Envirotech Corp. v. Al George, Inc., 730 F.2d 753, 221 U.S.P.Q. 473,477 (Fed. Cir. 1984); Roberts Dairy Co. v. United States, 530 F.2d 1324, 1337, 182 U.S.P.Q. 218, 225, aff'd 198 U.S.P.Q. 383 (Ct. Cl. 1976).

Complainant, in its pre-hearing statement, presented the following chart relating its claim 1 to Krohne's infringing device:

Claim 1 of U.S. Patent 4,420,982

Krohne's Infringing Device

A flangeless electromagnetic flowmeter unit interposable between the end flanges of the upstream and downstream pipes of a line conducting a fluid whose flow rate is to be metered, the end flanges of the pipes having a predetermined diameter and a circle of bolt holes, said unit comprising:

- A. a cylindrical metal housing having an external diameter which is smaller than that of the circle whereby when the unit is interposed between the end flanges of the pipes, the housing lies within the circle and the flanges are bridged by bolts passing through the holes to engage the unit and subject it to a compressive force effecting a fluid seal;
- B. a non-magnetic spool coaxially disposed within said housing and provided with end flanges which are seated against the ends of the upstream and downstream pipes and define with said housing an internal cavity, said spool forming a fluid conduit having a longitudinal flow axis which joins the upstream and downstream pipes, said spool having a strength sufficient to withstand the pressure of fluid flowing in the conduit and said compressive force;
- C. a pair of electromagnet coils disposed at diametrically-opposed sides of said spool to create a magnetic field whose lines of flux extend across the conduit, said coils lying on a coil axis which is normal to said flow axis; and
- D. a pair of electrodes mounted on said spool at diametrically-opposed positions along an electrode axis perpendicular both to the coil axis and to the flow axis whereby the fluid which flows through the conduit intersects said lines of flux to induce a signal in said electrodes which is a function of flow rate.

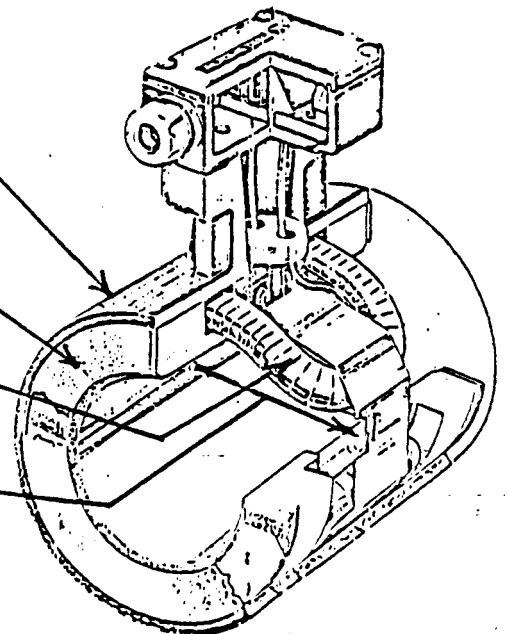
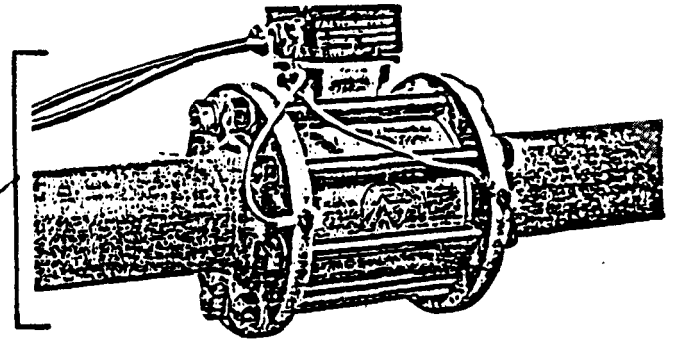

Complainant also argues that the most knowledgeable technical witness for Krohne, R. Barclay Beahm, General Manager of Krohne America, admitted at RX-1, para. 10) that the housing of the Krohne flowmeter of less than 2 inch lies within the flange bolt (clause A of claim 1). Also complainant argues that the less than 2 inch meter does not use magnetic straps<sup>19/</sup> so that all of

<sup>19/</sup> Magnetic straps in the Krohne 3 inch flowmeter is shown at RX-3, Fig. 1 at item 8.

the magnetic flux travels through the ferromagnetic housing within the circle of the bolt holes. (CPost at 22, 23).

Respondents argue that in Krohne's flowmeters the spool contacts the pipe flanges and thus bears the "entire" compressive load and hence, to the extent that the claims require a sharing of the compressive load between the housing and the spool, Krohne's meters do not infringe. It is further argued that the housing in Krohne's flowmeters of sizes less than 2 inch extends beyond the circle of bolt holes, while in Krohne's flowmeters of sizes of 2 inch and greater, the housing does not provide the return path for the flux. (RPost at 20, 21).

#### Krohne's Less than 2 Inch Meter

Illustrative of allegedly infringing less than 2 inch conduit diameter flowmeter is the Krohne 1/4 inch ALTOFLUX flowmeter. (CPX-24).

Determining infringement requires claim construction. Fromson v. Advance Offset Plate, Inc., 720 F.2d 1565, 219 U.S.P.Q. 1137, 1140 (Fed. Cir. 1983). If the properly construed claims read on the infringing device, there is literal infringement. However to understand the meaning of the claims, the claims must be construed with the specification. Id. at 1971, 219 U.S.P.Q. at 1142.

During closing argument complainant's counsel argued that "the small [Krohne CPX-24] meter substantially comes within the literal language of Claim 1" (Tr. at 2024) and that "with regard to equivalency, I don't rely on equivalency." (Tr. at 2034).

Independent claim 1 covers a flangeless flowmeter containing "a cylindrical metal housing" having an external diameter which is smaller than that of the circle of bolt holes whereby, when the flowmeter unit is interposed between the end flanges of the upstream and downstream pipes the cylindrical metal housing lies "within the circle" of bolt holes. (FF 17).

In the specification of the '982 patent inventor Schmooch under the subheading "Background of Invention" discloses that in his related '340 patent there is disclosed a flangeless flowmeter containing two magnet cores which extend at diametrically opposed positions along an axis normal to the longitudinal axis of a cylindrical housing, the cores being surrounded by coils to define solenoid-type electromagnets (which the less than 2 inch Krohne CPX-24 has (FF 163)) with two electrodes mounted on the spool at diametrically opposed positions along a transverse axis at right angles to the core axis. (FF 25). It is said by inventor Schmooch that this prior arrangement in the related '340 patent is appropriate to flowmeters having flow conduits of small diameter such as one inch but unsuitable for larger diameters - "that is, diameters of two, three and four inches and greater." (FF 26). Thereafter under the subheading "Summary of Invention" inventor Schmooch states that a flowmeter in accordance with the invention of the '982 patent, includes a non-magnetic spool of high mechanical strength and having end flanges. The inner surface of the spool is said to be covered by an insulating liner to provide a flow conduit for the fluid to be metered, the diameter of the conduit "being at least 2 inches." (FF 29). Surrounding the spool is "a cylindrical housing". (FF 30). Under the subheading "Description of Invention" it is disclosed that the compressive force is generated by bolts which bridge the flanges of the upstream and downstream pipes "between which the [flowmeter] unit is interposed in a fluid line." (FF 32); and that, as shown by Figure 7, bolts "bridge the flanges and encage the unit." Again "a cylindrical housing" is referred to. (FF 33). Figure 7 shows the entire cylindrical metal housing within the circle of bolt holes. (FF 37).

Neither Krohne's R. Barclay Beahm nor complainant's expert Prof. Blanco qualified as an expert on patent law. However complainant's expert Prof. Blanco testified that the coils in the less than 2 inch conduit diameter

(small) Krohne flowmeter are not disposed in a cavity defined by the housing and the spool but rather extend into a cavity. (FF 171). He further testified that whereas a cylindrical section of the small Krohne flowmeter lies within the circle of bolt holes of the flanges, there are two protruding sections of housing above and below the cylindrical section that lie outside the circle of bolt holes. (FF 222). Observation of Krohne's small flowmeter shows (CPX-24) that the housing is not "a cylindrical housing". Respondents' expert Mr. Liptak testified that housing in the small Krohne flowmeter lies outside the bolt circle of pipeline flanges. (FF 313). In addition there is testimony that in the small Krohne flowmeter the magnetic return path is beginning at the top of the coils which is outside the circular section of the housing; that magnetic field lines are passing through sections of coil not only within the circle of bolt holes but outside the circle of bolt holes; and that every flux line travels not only within the circle of bolt holes but also outside the circle. (FF 411). Hence a portion of the operating function of the Krohne small flowmeter lies outside the cylindrical section of the housing of the flowmeter.

An examination of the file wrapper of the '982 patent (FF 39-53) does not disclose that the claimed invention of the '982 patent was broadened over the clear teaching of the claims and the specification of the '982 patent that the claimed flangeless flowmeter contains (1) a flow conduit of at least 2 inches and (2) a "cylindrical" housing which is (3) "within" a circle of bolt holes.

The administrative law judge finds that the language of independent claim 1, supported by the specification, of the '982 patent limits the housing of the claimed flowmeter to a "cylindrical housing" that is within the bolt holes and to a flowmeter which has a flow conduit diameter of at least 2 inches.

Accordingly the administrative law judge finds that complainant has not met its burden, by a preponderance of evidence, in establishing that the

Krohne flowmeter of less than 2 inch conduit diameter in claims 1, 2 and 5 of the '982 patent.<sup>20/</sup>

Krohne's 2 Inch and Above Meter

Illustrative of the allegedly infringing 2 inch and above flowmeter is the Krohne DELTAFLUX 3 inch conduit diameter flowmeter. (CPX-23) (DELTAFLUX).<sup>21/</sup>

The DELTAFLUX, as well as the F&P MINI-MAG flowmeter (CPX-29, CPX-21) (MINI-MAG), is interposable between the end flanges of the upstream and downstream ends of a pipe line having a fluid whose flow rate is to be metered. (FF 143). The flanges on the ends of the upstream and downstream pipe portions for attachment to the MINI-MAG and DELTAFLUX have a predetermined diameter and a circle of bolt holes. (FF 144). The DELTAFLUX and MINI-MAG contain a cylindrical metal housing. (FF 145). The cylindrical metal housing of each has an external diameter smaller than that of the circle of bolt holes. (FF 146). The end portions of each of the MINI-MAG and

---

<sup>20/</sup> Respondents during the hearing moved to strike the testimony of any witness that relates to the small Krohne CPX-24 flowmeter on the ground that complainant has admitted that its MINI-MAG and K-MAG magnetic flowmeters in sizes smaller than 2 inches are not built in accordance with the '982 patent. (Tr. at 582, 583). The motion is denied on mootness in view of the finding of non-infringement by the Krohne flowmeter smaller than 2 inches.

<sup>21/</sup> Mr. Liptak, respondents' expert, and Mr. Beahm have referred to the superior design features of the Krohne magmeters such as ceramic flow tube, high accuracy electronics, fused platinum electrodes and remote range capability. (FF 317, 318, 382). An infringer does not escape infringement by improving on a patentee's invention or by adding to the patented invention even though the addition is important to the use intended for the resulting article. Temco Electroc Motor Co. v. Apco Mfg. Co., 275 U.S. 319, 328 (1928); A.B. Dick Co. v. Burroughs Corp. 713 F.2d 700, 218 U.S.P.Q. 965 (Fed. Cir. 1983 (cert. denied 52 U.S.L.W. 3509 (Jan. 9, 1984); Martston v. J.C. Penny Co., 353 F.2d 976, 985, 148 U.S.P.Q. 25, 32 (4th Cir. 1965), cert. denied 385 U.S. 974, 151 U.S.P.Q. 757 (1966). 1 Walker on Patents 409 and 432 (6th Ed. 1929).



DELTAFLUX are bridged by bolts passing through the holes in the pipe flanges to engage the flowmeter units and subject the flowmeter units to a compressive force effecting a fluid seal. (FF 147). In the MINI-MAG the force relationship is resisted by the spool and the housing. The compressive force is transferred from the face of the spool to the housing. The top of the housing is joined to the spool through a notch. Welding is used to join the spool to the housing. (FF 148). In the DELTAFLUX the spool and housing are joined by shrink fitting which is an operation that requires the heating of the outside housing, slipping the heated housing over the coils and allowing the housing to cool and shrink over the surface of the spool to obtain a good joint. (FF 149). In the DELTAFLUX the compressive forces are shared between the spool and the housing. (FF 150).

Respondents' expert Mr. Liptak agreed that in the DELTAFLUX after the housing is shrunk onto the spool/coil assembly the compressive load which is applied to the spool is transferred to the housing at least in part because of the tight fit between the housing and the spool. (FF 297). Moreover the sharing of the forces between the spool and the housing in the DELTAFLUX was established by tests conducted under the direction of Prof. Blanco and set forth in a video tape (CPX-35) (FF 151, 152, 153, 223, 224, 225). The tests involved a computer display of the mathematical phenomenon that occurred when a compressive force is applied to the DELTAFLUX. (FF 152). The tests are accepted in industry and in engineering. (FF 152).<sup>22/</sup> The tests showed

---

<sup>22/</sup> At the hearing on May 16 respondents' counsel objected to the admission into evidence of the tests' underlying written reports, including calculations, on the ground that respondents had not had an adequate opportunity to examine the calculations. Respondents' counsel had seen the video tape on May 15 but stated that he had not a chance to discuss it in detail with respondents' expert Mr. Liptak. With no objection from

(Footnote continued to page 54)

that even with the unrealistic presence of an air gap between the spool and the housing when the Krohne spool of the allegedly infringing flowmeter is compressed a part of the compressive force is transferred to the housing. (FF 151, 152, 153, 223, 224, 225). Since in the DELTAFLUX the spool and housing are joined by shrink fitting (FF 149), Prof. Blanco testified that there is a guarantee that under normal temperature differences and the normal gradients between the inside and the outside of the spool, there is always a substantial force transmitted between the spool and the housing (FF 225), which testimony is consistent with Mr. Liptak's testimony that there is a transfer of compressive force from the spool to the housing. (FF 297). It is a fact that allegedly infringing Krohne flowmeters have their spool and housing "intimately connected" and have unmatched resistance to extreme temperature changes. (FF 249, 328, 329). Krohne housings have very tight tolerances. (FF 432).

Each of the MINI-MAG and the DELTAFLUX comprises a non-magnetic spool coaxially disposed within its housing, i.e. the spool is exactly in the center of the housing and supported by the housing. (FF 155). Each defines a cavity by the joint between the top of the housing and the spool. (FF 158). Each has a fluid conduit within the spool having a longitudinal flow axis which

---

(Footnote continued from page 53)

respondents' counsel, complainant's evidentiary offer of the tests' underlying calculations were withdrawn by complainant, but the video tape (CPX-35) was admitted into evidence and viewed at the hearing on Friday May 16. (Tr. at 591 - 622). Respondents' expert was present for the viewing of the video tape. Complainant's expert Prof. Blanco testified on May 16 about the tests. Respondents' expert was present for the testimony. The video tape (CPX-35) was made available to respondents and respondents' expert for the remainder of the hearing. (Tr. at 620, 621). Complainant's counsel represented on May 16 that Prof. Blanco would be available for cross-examination by respondents the week of May 19 even if complainant did not put on a rebuttal case. On May 16 and Tuesday May 20, Prof. Blanco was cross-examined in the presence of respondents' expert. Respondents' expert Mr. Liptak testified on May 20 and 21.

joins the upstream and the downstream pipes with the conduit being between the flanges with the two flanges receiving pressure from the end flanges of upstream and downstream pipes. (FF 159, 160). Each of the MINI-MAG and the DELTAFLUX has a strength sufficient to withstand the pressure of fluid flowing in the conduit and the compressive force applied through the bolts. (FF 161). Each has a pair of electromagnetic coils disposed at diametrically opposed sides of its spool to create a magnetic field whose lines of flux extend the conduit of the spool. The coils in both are saddle-shaped coils. (FF 162). In both the shape of the coils conform to the curvature of the housing. (FF 173). In both the MINI-MAG and DELTA-FLUX coils essentially lie in the same relationship. (FF 164). Each of the MINI-MAG and the DELTAFLUX has a pair of electrodes mounted on a spool with the electrodes at diametrically opposed positions which is along an electrode axis perpendicular both to the coil axis and to the flow axis. (FF 166, 167, 168). In each coils are disposed in the cavity as called for by claim 2 of the '982 patent. (FF 17, 170). In each the coils are saddle-shaped as called for by claim 3. (FF 17, 172). Referring to claim 4, in each the coils conform to the curvature of the housing. (FF 173). Referring to claim 5 in the MINI-MAG the cylindrical housing is formed of ferromagnetic material which joins the electromagnetic coils to define a magnetic circuit. (FF 174). While the DELTAFLUX has a magnetic strap, (See RX-3, Fig. 1 at item 8) the cylindrical housing of the DELTAFLUX is ferromagnetic. (FF 174). The ferromagnetic housing joins the electromagnetic coils to define a magnetic circuit. (FF 174). Claim 5 of the '982 patent does not require that all of the magnetic flux travel through the ferromagnetic housing. (FF 17).

Respondents argue that Prof. Blanco found the DELTAFLUX to have a ferromagnetic housing defining a magnetic circuit with the coils solely on the basis of testing the housing with a magnet to see if the housing was of

magnetic material and that while this test may tell whether the material is magnetic, the test cannot tell whether the material is in a magnetic circuit with other elements. (RPF P79). However Prof. Blanco's testimony was not limited to merely testing the DELTAFLUX housing to see if it was ferromagnetic. Rather Prof. Blanco, who was qualified as an expert in the field of mechanical engineering design, including structural and force relationship in electromagnetic devices (FF 137), testified that, in the DELTAFLUX, coils are above and below the spool and surrounding the spool is a ferromagnetic material which obviously is the type of path that a magnetic flow would follow. (FF 218). Moreover respondents' expert Mr. Liptak testified that the magnetic return path of the DELTAFLUX does include the housing. (FF 315).

Respondents argued that Krohne's spool carries "the compressive load, and that these spools have been certified by an independent German testing laboratory, TUEV [TUV], for their ability to carry this load." (Hofmann, Tr. 1675, 1.25- Tr. 1677, 1.4)" (RPF P82). This was the sole evidence proffered by respondents in their proposed findings submitted on June 9 to support the proposition that respondents' housing does not share in the compressive force applied to the flowmeter. The administrative law judge can find nothing in the TUV report which establishes that the DELTAFLUX housing does not share any compressive force exerted upon the DELTAFLUX or that the DELTAFLUX spool is incapable of supporting compressive forces exerted upon it by the end flanges of a pipe. (FF 396). In respondents' reply findings dated June 16 (RPF at 17) respondents, relying on live testimony of Mr. Hofmann (Tr. at 1669, 1670, 1671), argued that, in the Krohne flowmeters, the housing is a cast or malleable iron which is a poor magnetic conductor; that respondents' meters of size two inches and larger use magnetic straps as the return path for the flux; that "nearly all" the flux goes through the straps; and that respondents' "housing takes only an insignificant part of the compressive forces. (RPF at 17).

Complainant's Motion No. 230-6 filed June 10, 1986 moved to strike the alleged uncorroborated, double hearsay irrelevant testimony of Mr. Hofmann on whether the Krohne housing provides or does not provide a magnetic strap return path for the magnetic flux and on the whether the Krohne housing shares or does not share the compressive load with the spool. Complainant argues that the Hofmann witness statement (direct testimony), (RX-11), submitted before the hearing, misled complainant; that although Hofmann's witness statement included a major section entitled "USE OF THE MAGNETIC FLOW METER HOUSING AS THE MAGNETIC FLOW PATH", the statement did not deny the accuracy of the section title as it pertained to the Krohne housing; that the statement was completely silent about the Krohne housing providing or not providing a magnetic return path for the magnetic flux; that nothing was said about the Krohne housing sharing or not sharing the compressive load with the spool; and that nothing was said about any internal Krohne testing regarding these functions of the Krohne housing. Complainant also argues that during the discovery period Mr. Hofmann was not identified as knowledgeable on magnetic return path or compressive load. Also it was argued that the internal Krohne documents which Mr. Hofmann referred to in his live testimony were not identified, much less produced; that this was even though counsel for F&P traveled to Germany to examine documents and to depose witnesses designated pursuant to detailed requests, attached as Exhibits A-D to Motion No. 230-6, precisely covering this area pursuant to Rules 30(b)(5) and (6), F.R.C.P.

Complainant further argues that while hearsay evidence per se is not to be excluded in an administrative proceeding, "the matter, comes down to the question of the procedure's integrity and fundamental fairness." Richardson v. Perales 402 US 389, 410 (1971); and when accepting hearsay evidence, a number of factors must be considered to insure the underlying reliability and probative value of such evidence, id. at 402 and Calhoun v. Bailer 626 F.2d

145, 149 (9th Cir. 1980), discussing Richardson. Specifically it was said that Richardson requires the following be considered:

1. The independence or possible bias of the declarant;
2. The type of hearsay material submitted, for example, in Richardson, the evidence comprised written independent medical reports routinely prepared and submitted by medical doctors in disability cases;
3. Whether the statements are signed and sworn to as opposed to oral or unsworn;
4. Whether or not the statements are contradicted by direct testimony;
5. Whether or not the declarant is available to testify;
6. Whether or not the party objecting to the hearsay statements subpoenaed the declarant;
7. Whether the declarant is unavailable and no other evidence is available;
8. The credibility of the declarant as a witness, or of the witness testifying to the hearsay; and
9. Whether or not the hearsay is corroborated.

Responding on June 16, 1986 to Motion No. 230-6, respondents argue that:

"Mr. Hofmann's testimony was not introduced to prove the truth of the tests to which Complainant objects; rather the testimony regarding the tests and other information were introduced as a basis for Mr. Hofmann's conclusions that (1) the housing does not bear a substantial amount of the compressive force and (2) the housing does not have more than 5% of the total flux of the magnetic circuit traveling therethrough." (response at 2).

Respondents further argue that the fact that respondents' expert Mr. Liptak and complainant's expert Prof. Blanco testified that force is applied to the housing (response at 4) does not contradict the testimony of Mr. Hofmann that the housing takes less than 10 percent of the compressive load; and that the testimony of Prof. Blanco, that the housing is part of the magnetic circuit, and the testimony of Mr. Liptak, that the housing is part of the magnetic

return path (response at 4) do not contradict the testimony of Mr. Hofmann that only 5 percent of total flux of the magnetic circuit passes through the housing. Respondents in the response to Motion No. 230-6 also, in addition to the TUV report discussed above, rely on two other Stevens deposition exhibits, viz. Exh. 28 (a survey report) and Exh. 29 (a research report) as tests to support Mr. Hofmann's testimony. (response at 3)

At the hearing Krohne's Mr. Hofmann testified that 97 percent of the total flux passes through the straps of the Krohne flowmeter shown in Fig. 1 at 8 of Mr. Liptak's witness statement (FF 384) which would mean that only 3 percent could pass through the Krohne housing. However he admitted that his testimony with regard to whether the magnetic flow path was primarily through the housing of the Krohne flowmeter or primarily through the straps of the Krohne flowmeter was based on information given to Mr. Hofmann by an unidentifiable person at Krohne. (FF 409). At the hearing Krohne offered no evidence in support of Mr. Hofmann's testimony that 97 percent of the total flux passes through the Krohne straps. Mr. Hofmann was not qualified as an expert as was respondents' expert Mr. Liptak.

Mr. Liptak testified that he asked the unidentified Krohne designers how much magnetic flux is carried by the Krohne magnetic strap and the housing and hence is fully satisfied that the overwhelming majority of flux is carried by the strap. He testified that he had received very specific information from people "more knowledgeable than I am". (FF 292). Mr. Liptak admitted that he had conducted no test of the Krohne flowmeter to determine whether the magnetic return path is primarily in the ferromagnetic housing as compared to the flux lines in the strap. (FF 291). Mr. Liptak did not identify the Krohne people he talked with and he presented no information which the Krohne people were said to have given him. (FF 292). Mr. Liptak saw no test data. (FF 292). Mr. Liptak admitted that the thickness of a ferromagnetic material

is relevant to determining its efficiency in carrying flux. On visual observation he testified that the housing of the Krohne flowmeter is thicker than the strap of the flowmeter and that the thickness of the strap is substantially less than that of the housing. (FF 292).

The uncorroborated, undocumented testimony of Messrs. Liptak and Hofmann is in striking contrast to the Krohne March 17, 1981 report about the X-1000 which stated:

"Metal round housing is used as magnetic return path (as usual since years with our larger meters types 63,960). If possible, this housing should be placed under the connection bolts"  
(FF 356) (Emphasis added) (See also Krohne 11/28/80 memo at 34)

At the hearing Mr. Hofmann testified that only about 12 percent of the compressive force applied to the Krohne flowmeter unit was shared by the housing. Mr. Hofmann did not perform the test. It was not performed within his viewing nor in his presence. (FF 401). Respondents provided no documentary evidence in support of Mr. Hofmann's testimony that only about 12 percent of the compressive force was shared by the housing.

Mr. Hofmann testified about calculations in which he was able to calculate the amount of forces that may be transferred between the spool and the housing of the Krohne flowmeter. The calculations were done the day before his testimony to reconfirm data which he remembered. (FF 392). Respondents have not provided any documentation on the data Mr. Hofmann remembered.

Mr. Hofmann testified that, in Germany, Krohne subjected a spool to compressive force by applying such force to opposite faces of the spool and measured the shortening of the length of the spool relative to the different compressive forces and that this was done especially in the larger size flowmeters such as the 3 inch flowmeter (CPX-23). (FF 398). Respondents provided no documentation of such tests.



The administrative law judge can find nothing in the Stevens deposition exhibits 28, 29, 30 which corroborates Mr. Hofmann's testimony that only about 5 percent of total flux of the magnetic circuit passes through the Krohne housing nor is the administrative law judge able to find anything in Stevens deposition exhibits 28 and 29 that corroborates the testimony of Mr. Hofmann that only about 12 percent of the compressive force applied to the Krohne flowmeter unit was shared by the housing.<sup>23/</sup>

The administrative law judge does not find persuasive respondent's argument, in responding to Motion No. 230-6, that Mr. Hofmann's testimony was not introduced "to prove the truth of the tests" to which complainant objects but that the Hofmann "testimony regarding the tests and other information were introduced as a basis for Mr. Hofmann's conclusions"; and that Mr. Hofmann's testified on "types of records and knowledge which are kept in the ordinary course of Krohne's business and would ordinarily be made known to persons in Mr. Hofmann's position". (response at 2). Assuming the records qualify as records of regularly conducted activities, the records should have been produced to allow complainant an opportunity for cross examination. See Rule 802(6) of Federal Rules of Evidence.

---

<sup>23/</sup> On whether the Krohne housing shares in the applied compressive force the deposition testimony of A. Roskam, the managing director of Krohne's wholly owned subsidiary Altometer which manufactured the primary portions of Krohne's electromagnetic flowmeters i.e. the portion of the flowmeter which is physically positioned in the flow line as opposed to the electronic portion of the flowmeter is contradictory. (FF 424). In deposition when he was asked whether the housing in the DELTAFLUX lend physical support to the spool with respect to the compressive forces which are exerted on the spool during use he answered that the housing reinforces the spool. Later in deposition when asked whether the housing supports the liner of the spool or reinforces the liner against compressive forces when it is mounted into a pipeline he answered "No." (FF 433, 434). No corroborative test data was offered to support the Roskam deposition testimony which on its face is conflicting.

Evidence in an administrative proceeding must be of sufficient "reliability" and "probative value" to justify its use. Richardson v Perales 402 U.S. at 402. The kind of evidence that was offered against claimant by the government in Perales consisted of medical reports which as a class of evidence are generally held to be fairly trustworthy. In addition the reports were essentially consistent with each other in their general findings. Id. 402 U.S. at 404.

Finally the Perales decision emphasized the Court's willingness to consider certain kinds of uncorroborated hearsay as sufficient evidence when the claimant fails to exercise a right to subpoena. Id. at 402.

In this investigation Mr. Hofmann was not qualified as an expert witness. It was not shown that he had any responsibility for either supervising or conducting the tests on which his conclusions are based. Complainant was not given the opportunity to examine the persons who supervised the testing or had any responsibility for performing the tests on which Mr. Hofmann's conclusions were based because, until Mr. Hofmann's live testimony, complainant had no knowledge of Mr. Hofmann's conclusions. No records of regularly conducted activity were produced to support the specific percentages Mr. Hofmann testified to. Accordingly the administrative law judge is giving no weight to what respondents have admitted are Mr. Hofmann's "conclusions that (1) the [Krohne] housing [sharing only about 12 percent of the applied compressive load], does not bear a substantial amount of the compressive force and (2) the [Krohne] housing does not have more than 5%

of the total flux of the magnetic circuit traveling therethrough".<sup>24/</sup>

Finally respondents in their response to Motion No. 230-6 acknowledge the fact that their expert Mr. Liptak testified that the housing is part of the magnetic return path and that compressive force is applied to the housing. Claims 1 and 5 of the '982 patent do not quantify the amount of compressive force shared by the housing nor the amount of flux which travels through the ferromagnetic housing.

Based on the foregoing the administrative law judge finds that complainant has met its burden, by a preponderance of evidence, in establishing that the allegedly infringing Krohne flowmeter of 2 inch and above infringes claims 1, 2, 3, 4 and 5 of the '982 patent.<sup>25/</sup>

#### C. Full and Fair Disclosure

Respondents argue that the '982 patent is not valid or not enforceable because complainant abused the trust of the U.S. Patent and Trademark Office and failed to fulfill its duty of full and fair disclosure. It is argued that

---

<sup>24/</sup> Because an administrative proceeding is involved in this investigation, the administrative law judge is denying complainant's Motion No. 230-6. See Samuel H. Moss, Inc. v. FTC 148 F.2d 378, 380 (2d Cir. 1945), cert. denied 326 U.S. 7324 (1946).

<sup>25/</sup> Although neither monetary damages nor attorney fees are available to a complainant in this proceeding, complainant argues that respondents' infringement has been willful and deliberate, citing Central Soya Co., Inc. v. Geo. A. Hormel & Co., 723 F. 2d 1573, 1577 219 U.S.P.Q. 878 (Fed. Cir. 1983). A finding of willful infringement is dependent on the surrounding circumstances of each case. In Central Soya the district court found the infringer's legal department became concerned about infringing plaintiff's patent. The evidence shows no such concern by respondents' legal department. If an infringer is honestly mistaken as to a reasonably debatable question of  
(Footnote continued to page 64)

complainant was well aware of the British Sybron patent during the pendency of the application that led to the '982 patent; that the British Sybron patent was clearly more material than any reference the U.S. patent examiner had before him during said pendency and that complainant had to have been aware of this; and that complainant failed to call the British Sybron patent to the attention of the U.S. patent examiner. (RPost at 20). Respondents further argue that, even allowing the broadest charitable concession that the failure to cite the British Sybron patent to the U.S. patent examiner might not have been "wilful" but merely grossly negligent, the failure is inequitable conduct of such magnitude as to render the '982 patent invalid or unenforceable. (RPostR at 16).

Respondents further argue that complainant failed to disclose to the U.S. Patent Office the true inventorship for the "improvements" claimed in the '982 patent; that a Richard Crumley was the person who invented the "thin coil" approach which enabled the claimed flowmeter of the '982 patent to fit wholly within the circle of bolt holes and that Crumley filed an invention disclosure with complainant on this invention; and that nonetheless, in order to obtain the benefit of a parent (parent to the '982 patent) application filing date, complainant knowingly filed a later parent application (also parent to the '982 patent) in the name of Schmoock, not in the name of Crumley, and that in so doing it committed affirmative fraud on the Patent Office. (RPost at 20).

Establishing that a patent was procured by fraud or with such egregious conduct as to render it unenforceable requires clear, unequivocal, and

---

(Footnote continued from page 63)  
validity, an infringement is not wilful and thus punitive damages should not be awarded. Eltra Corp. v. Basic, Inc., 599 F.2d 745, 755, 202 U.S.P.Q. 630, 640 (6th Circuit 1979). The administrative law judge does not find that there has been a wilful infringement.

convincing evidence of an intentional misrepresentation or withholding of a material fact from the Patent Office. Orthopedic Equipment Co. v. All Orthopedic Appliances, Inc. 707 F.2d 1376, 1383, 217 U.S.P.Q. 1281, 1286 (Fed. Cir. 1983); Square Liner 360, Inc. v. Chisum, 691 F.2d 362, 374, 216 U.S.P.Q. 666, 674-75 (8th Cir. 1982)

#### Failure to Cite the British Sybron Patent

Critical to this affirmative defense is the issue of materiality. In American Hoist & Derrick v. Sowa & Sons, Inc. 725 F.2d 1350, 1362, 220 U.S.P.Q. 763, 772, 773 (Fed. Cir. 1984), the Federal Circuit referred to four standards of materiality for disclosure to the Patent Office: (1) an objective "but for" standard, (2) a subjective "but for" standard, (3) a "but it may have" standard and (4) Patent Office Rule 1.56 (a).<sup>26/</sup>

The Patent Office "standard" is an appropriate starting point for any discussion of materiality for it appears to be the broadest standard, thus encompassing the other standards, and because the Patent Office materiality standard most clearly aligns with how one ought to conduct business with the Patent Office. American Hoist v Sowa supra. at 1362, 220 U.S.P.Q. at 772, 773. The Court in American Hoist however made it clear that there is no reason to be bound by any one single standard because the answer to any inquiry into fraud on the Patent Office does not begin and end with materiality nor can materiality be said to be unconnected to other considerations. Thus it was said that where an objective "but for" inquiry is satisfied under the appropriate standard of proof and although one is not

---

<sup>26/</sup> Patent Office Rule 1.56(a) states that information is material where there is [1] a substantial likelihood that [2] a reasonable examiner [3] would consider it important [4] in deciding whether to allow the application in issue as a patent. 37 C.F.R. 1.56(a) third sentence (1985).

necessarily grossly negligent in failing to anticipate judicial resolution of validity, a lesser showing of facts from which intent can be inferred may be sufficient to justify holding a patent invalid or unenforceable, in whole or in part; that conversely where it is demonstrated that a reasonable examiner would merely have considered particular information to be important but not crucial in his decision not to reject, a showing of facts which would indicate something more than gross negligence or recklessness may be required, and good faith judgment or honest mistake might well be a sufficient defense. Id. Hence the pertinency of the withheld information should be an initial determination. Thereafter, in light of the pertinency, the question of materiality and the degree thereof can be resolved.

It has already been found by the administrative law judge that respondents have not established, by clear and convincing evidence, that claims 1 through 5 of the '982 patent are not valid under 35 U.S.C. 102 and/or 103 in view of the British Sybron patent.

Respondents argue that the prosecution of complainant's Australian and British applications is evidence of the materiality of the British Sybron patent. However in each of the British and Australian prosecutions, the British Sybron patent appears to have been overcome as a reference.

(FF 70-76, 120).<sup>27/</sup>

---

<sup>27/</sup> The weight to be given to the prosecution of foreign patent applications and the prior art cited by foreign patent offices is inconclusive, on the issue of materiality, insofar as what should be cited to the U.S. Patent Office because the standards of patentability differ from country to country. See Skill Corp. v. Lucerne Products, Inc., 684 F.2d 346, 351, 216 U.S.P.Q. 371, 374, 375 (6th Cir. 1982), Timely Products Corp. v. Arron, 523 F.2d 288, 295, 187 U.S.P.Q. 257, 261 (2d Cir. 1975), Ditto Incorporated v. Minnesota Mining & Mfg. Co., 336 F.2d 67, 70-71 142 U.S.P.Q. 416 (8th Cir. 1964), Western Electric Co. v. Milgo Electric Corp., 450 F. Supp. 835, 839, 200 U.S.P.Q. 30, 33 (S.D. Fla. 1978), Cryomedics, Inc. v. Frigitronics of Conn.

(Footnote continued to page 67)

More relevant to the pertinency of the British Sybron patent is its citation by the U.S. patent examiner during the prosecution of Ser. No. 536,275 which led to the issuance of the complainant's '212 patent to inventor Schmoock. (FF 54-57). Respondents argue that, in the prosecution of the '212 patent, the February 24, 1984 Patent Office action, which cited the British Sybron patent, was subsequent to the issuance of the '982 patent on Dec. 20, 1983 and that the claimed invention of the '212 patent is totally different from the claimed invention of the '982 patent. (Tr. at 2061, 2062).

Substantially identical arguments made by complainant in this investigation for patentability of the '982 patent over the British Sybron patent were made in the prosecution for the '212 patent to distinguish the claimed subject matter over the British Sybron patent. Thus it was argued in the prosecution for the '212 patent that the compressive force in the claimed subject matter before the U.S. patent examiner is shared by both the housing and the spool with the spool and the cylindrical housing being the same length and engaged by the end flanges of the pipes; and that, in contrast, in the British Sybron patent, if the metal cover is regarded as equivalent to what is claimed in Ser. No. 536,275, the cover is not engaged by the end flanges of the pipes. (FF 58). Contrary to respondents' argument, the prosecution of the '212 patent shows that the U.S. patent examiner did not find the claimed invention, in what became the '212 patent, to be totally different from the claimed invention in the '982 patent. This is demonstrated by the fact that the examiner rejected the claimed subject matter in Ser. No. 536,275 over the claims of the '982 patent in view of the Sybron patent taking the position that public policy intended to prevent prolongation of a monopoly by

---

(Footnote continued from page 66)  
Inc., 196 U.S.P.Q. 526 (D. Conn. 1977), Duplan Corp. v. Deering Milliken, Inc., 444 F. Supp. 648, 686, 197 U.S.P.Q. 342, 376 (D.S.C. 1977).

prohibiting claims in a second patent not "patentably distinct" from claims in the '982 patent. (FF 57). It was only after a terminal disclaimer was filed wherein complainant agreed that the '212 patent shall be enforceable only during the life of the '982 patent (FF 59) that the '212 patent issued. Hence the claimed subject matter of the '212 patent was considered by the U.S. examiner not to be patentably distinct from the claimed subject matter of the '982 patent. Yet the primary examiner who allowed the claims of the '982 patent allowed the claims of the '212 patent (FF 54) even though he had initially rejected the claimed subject matter of the '212 patent as anticipated and obvious over the British Sybron patent. (FF 57). If the British Sybron patent is as pertinent as respondents argue, the '212 patent should never have issued. Accordingly the administrative law judge finds that the examiner did not consider the British Sybron patent pertinent with respect to claimed subject matter patentability indistinct from subject matter claimed in the '982 patent.<sup>28/</sup>

With respect to the element of intent, the attorney who prosecuted the application that led to the '982 patent was aware of the British Sybron patent during said prosecution of the U.S. application. (FF 109, 133).<sup>29/</sup> However in not citing the British Sybron patent the evidence demonstrates that the attorney was exercising good faith judgment. (FF 110, 111, 112, 114, 115, 125, 126, 130, 134).

---

<sup>28/</sup> It is noted that while the '212 patent is based on a divisional application (i.e. a common disclosure) of Ser. No. 398,809 on which the '982 patent is based, the examiner did not prevent the issuance of the '212 patent, under 35 U.S.C § 112 because of a defective specification. See supra at 8-19

<sup>29/</sup> An applicant for a patent is under no obligation to disclose "all pertinent prior art" of which he is aware. Digital Equipment Corp. v. Diamond 653 F 2d 701, 716, 210 U.S.P.Q. 521, 538 (1st Cir.1981).



Based on the foregoing the administrative law judge finds that respondents have not established by clear, unequivocal and convincing evidence that the '982 patent is not valid or not enforceable because of a failure to disclose the British Sybron patent to the U. S. patent examiner.<sup>30/</sup>

#### Inventorship Question

Respondents argue that Richard Crumley made the patented invention described in the '963 patent; that it was an invention disclosure, alleged to be that of Crumley, to the F&P patent department that enabled the size of the housing to be reduced sufficiently so that the bolts could be outside the housing and the housing could therefore lie within the circle of bolt holes which engage the flowmeter unit; that unlike the '118, '018 and '340 patents (on which the '982 patent is based (FF 16)), which used core solenoids for generating the magnetic field, the '963 patent (on which the '982 patent is also based) uses short magnet cores integral with the housing and thin saddle-shaped coils which slip over them; that the invention disclosure, alleged to be that of Crumley, dated October 31, 1978 (FF 376) entitled "Diamond Shaped Coils for Mini-Mag" was for an invention to package the magnet coils for the MINI-MAG design so they fit into the space outside the fluid conduit and inside a magnetic return path located inside the bolt circle of a standard flange; that for some inexplicable reason not only was Crumley's name omitted from the '963 patent but someone "we don't know whom," struck out

---

<sup>30/</sup> Respondents have pending a motion for production of attorney-client documents because of the withholding of the British Sybron patent during the prosecution of the application that led to the issuance of the '982 patent. In view of the finding by the administrative law judge that respondents have not sustained their burden in establishing that the '982 patent is not valid or is not enforceable because of the non-disclosure of the British Sybron patent to the U. S. patent examiner, respondents motion is denied.

Crumley's name and inserted the words "Schmoock CIP" on the invention disclosure dated October 31, 1978 (FF 376); that the application, viz. Ser. No. 174,609, on which the '963 patent, is based should have been a Crumley continuation-in-part application and not a Schmoock continuation-in-part application; that if Ser. No. 174,609 had been filed in the name of Crumley, at that time according to the law, Ser. No. 174,609 would not have been able to relate back in the chain of patent applications, viz. Ser. No. 075,037, Ser. No. 811,276 and Ser. No. 771,420; and that the earliest date Ser. No. 174,609 would have been entitled would have been the 1980 filing date of Ser. No. 174,609.<sup>31/</sup> (Tr. 1939, 1940). Respondents argue that whether or not a date earlier than 1980 is needed to sustain the validity of the '982 patent, "we don't know" but that the assignee F&P received an earlier date even though it was not entitled to it. (Tr. at 1940; RPost at 8,9)). This argument implies that Crumley should have been a named inventor on the '982 patent.

One seeking to challenge the validity of a patent for inventorship nonjoinder or misjoinder has a heavy burden. Inventorship is a technical defense and therefore disfavored. Chisum, 1 Patents § 2.03[4]. It must be established by clear and convincing evidence. Id. Certain Steel Rod Treating Apparatus and Components Thereof Inv. 337-TA-97 USITC Publication 1210 at 41 (January 1982).

---

<sup>31/</sup> The '982 patent discloses that it is based on an application that is the last application in a chain of five applications. Thus the '982 patent is based on Ser. No. 398,809 filed July 16, 1982 which is a divisional application of Ser. No. 174,609 filed August 1, 1980 (now the '963 patent). The Ser. No. 174,609 is said to be a continuation-in-part application of Ser. No. 75,037 filed September 12, 1979 (now the '340 patent) which is turn is a continuation-in-part application of Ser. No. 811,276 filed June 29, 1977 (now the '018 patent) which is turn is a divisional application of Ser, No, 771,420 filed Feb. 23, 1977 (now the '118 patent). (FF 16).

The record includes two invention disclosures of inventor Roy Schmooch on which applications that led to the issuance of the '982 patent are based. Thus an invention disclosure dated July 12, 1976 is to an effort to reduce the size and cost of existing magmeters. The patentable feature is said to be that the injection mold forming the liner and holding the electronics in conjunction with the outer magnetic return path form the structure that holds the coils and electrode leads and finally forms the potting mold. The outer magnetic return ring is said also to reinforce the pressure vessel. (FF 377).

A Roy Schmooch invention disclosure dated July 12, 1979 for a "Unitary Electromagnetic Flowmeter" is a continuance of the '118 patent and refers to the use of a lined metal spool. (FF 378). Respondents admit that the '340 patent is a result of this invention disclosure. (RPost at 7).

The administrative law judge finds the record lacking any evidence as to who in fact made the invention disclosed in what respondents refer to as the Crumley invention disclosure. The record is also lacking any evidence concerning the circumstances surrounding the crossing out of "Richard L. Crumley, Southampton, Pa." in the invention disclosure dated October 31, 1978. (FF 376). There is no evidence to show who did it or why it was done. That it was done to insure continuity of applications is based solely on respondents' argument.<sup>32/</sup> In addition the parent applications for the '118 and '018 patents, on which the '982 patent is based, were filed even before the June 8, 1978 conception date for the disclosure which is alleged to be for a Crumley invention. Although respondents argued the October 31, 1978 invention enabled the size of the housing to be reduced such that the housing

---

<sup>32/</sup> According to Motion No. 230-5 filed by complainant on May 12, 1986 what has been termed the Crumley invention disclosure (FF 376) was produced to respondents by complainant "more than five months ago."

can be encaged by bolts, Figure 8 of the '118 patent discloses a flowmeter unit encaged by bridging bolts as claimed in the '982 patent. The '982 patent does teach that cored solenoids are inappropriate in large diameter flowmeters; that thin coils as saddle-shaped coils or coils with a diamond or circular configuration (the coils being shaped to conform to the curvature of the housing) should be used. (FF 26, 27, 38). However saddle-shaped magnetic coils fitted on opposite sides of the inner surface of the meter body were used in prior art commercial electromagnetic flowmeters. (FF 68). These saddle shaped coils conformed to the curvature of the meter body. (FF 101).

For the foregoing reasons the administrative law judge finds that respondents have not established, by clear and convincing evidence, that the '982 patent is not valid or not enforceable because there has been a nonjoinder or misjoinder of inventorship on the '982 patent.<sup>33/</sup>

#### D. Laches

Respondents argue that the application on which the '982 patent was issued was filed on July 16, 1982 one month after respondent Krohne Messtechnik GmbH had publicly announced and demonstrated its new X-1000 and DELTAFLUX flowmeters at the June 1982 Achema Fair in Frankfurt, Federal Republic of Germany; that Krohne's introduction of the X-1000 was well

---

<sup>33/</sup> In November 1984 35 USC 116 was amended to allow inventors to apply for a patent jointly even though they did not physically work together or at the same time and did not make a contribution to the subject matter of every claim. Also Title 35 USC 120 was amended such that an application can obtain the benefit of a filing date of an earlier application when not all inventors named in the joint application are the same as those named in the earlier application.

publicized in the trade and engineers from complainant's German affiliate attended the fair in Frankfurt and examined Krohne's new development; and that the news of this development was quickly communicated to complainant's United States staff. (RPost at 4). Accordingly it is argued that the claims of the '982 patent were formulated and hastily filed only after seeing the Krohne meter and hence that complainant is estopped by laches from asserting infringement. (RPost at 21).

Laches arises when the patent owner reasonably and inexcusably delays filing suit for infringement to the material prejudice of the infringer. When the infringer proves laches, the patent owner may not recover damages for infringements occurring prior to the filing of the suit. The owner however may still obtain an injunction and damages as to post filing infringements unless the infringer further establishes the elements of an equitable estoppel. Chisum Patents 19.05[2]<sup>34/</sup>. Assuming the facts are as alleged by respondents the administrative law judge does not find the doctrine of laches applicable since in this investigation only injunctive relief is possible.

There is a doctrine which has been termed "late claiming" and which was given birth in Muncie Gear Works, Inc. v. Outboard Marine & Mfg. Co., 315 U.S.P.Q. 759, 53 U.S.P.Q. 1 (1942).<sup>35/</sup> The "late claiming" doctrine involves the insertion of claims in a patent application subsequent to the filing date of the application. The factual situation outlined by respondents

---

<sup>34/</sup> An equitable estoppel arises when (1) the patent owner through conduct, positive statements, or misleading silence represents to the infringer that his business will be unmolested by claims of infringement and (2) in reliance on that representation the infringer continues or expands his business. Chisum Patents 19.05[3]

<sup>35/</sup> The Federal Circuit recently stated that the patent infringement defense labeled as "late claiming" has long ago been discredited. Railroad Dynamics, Inc. v. A. Stucki Co. supra 220 U.S.P.Q. at 940.

does not involve insertion of claims in an application after the application was filed. However it does involve the filing of a later divisional (common disclosure) application Ser. No. 398,809 with newly asserted claims.

In Westphal v. Fawzi 666 F.2d 575, 212 U.S.P.Q. 321, 322 (CCPA 1981) Chief Judge Markey, writing for the Court of Customs and Patent Appeals (a predecessor court to the Federal Circuit) held that Muncie Gear should be interpreted as holding that claims are invalid "if there was public use, or sale . . . more than two years before the first disclosure thereof to the Patent Office" (Emphasis added). This was said to be an application of the statutory prohibition against introduction by amendment, after an application's filing date, of additional disclosure in an application and of claims directed thereto.

The disclosure of divisional Ser. No. 398,809 is common with Ser. No. 174,609 filed August 1, 1980 which date is more than a year before the Frankfurt fair even assuming that the disclosure at the Frankfurt Fair was a public disclosure in the United States which it was not. Therefore the administrative law judge finds the doctrine of late claiming inapposite.

For the foregoing reasons, the administrative law judge finds that respondents have not sustained their burden in establishing that complainant is estopped by laches from asserting infringement of the '982 patent.

E. Importation and Sale

To invoke the subject matter jurisdiction of the Commission and to support a finding that a violation of section 337 exists, complainant must establish that the accused flowmeters have been imported and/or sold in the United States. Krohne imported flangeless magnetic flowmeters into the United States during the period 1983 to Jan.-Oct. 1985. (FF 442). Of these, meters with diameters between 2-4 inches (valued at were sold during 1984-85. (FF 562). An additional flangeless magnetic flowmeters 2-4 inches in diameter were sold by Krohne America in the first quarter of 1986. (FF 563).

Based on the above facts, the administrative law judge determines that flowmeters alleged to infringe the suit patent have been imported into and sold in the United States and that the Commission has subject matter jurisdiction.

F. Domestic Industry

The Commission has customarily defined the domestic industry, in patent-based investigations, as the domestic operations of the patent owner and its licensees devoted to the exploitation of the patent. Schaper Manufacturing Co. v. U.S. International Trade Commission, 717 F.2d 1368, 1372 (Fed. Cir. 1983); Certain Methods for Extruding Plastic Tubing, Inv. 337-TA-110, 218 U.S.P.Q. 348 (1982); Certain Slide Fastener Stringers and Machines and Components Thereof, Inv. 337-TA-85, 216 U.S.P.Q. 907 (1981); see H.R. Rep. No. 93-571, 93 Cong., 1st Sess. 78 (1973). The domestic industry is not limited to manufacturing per se but may encompass distribution, research and development, and sales. Certain Personal Computers, Inv. 337-TA-140, 224 U.S.P.Q. 270 (1984). The Commission does not adhere to any rigid formula in

determining the scope of the domestic industry, as it is not precisely defined in the statute, but examines each case in light of the realities of the marketplace. Slide Fastener Stringers, 216 U.S.P.Q. 907; Certain Apparatus for the Continuous Production of Copper Rod, Inv. 337-TA-52, 206 U.S.P.Q. 138 (1979).

The '982 patent issued on December 20, 1983, so the industry at issue did not exist until that time. (FF 449). F&P sells two models of magnetic flowmeters manufactured under the '982 patent. These flowmeters are designated by the trademarks MINI-MAG and K-MAG and range from 1/10 inch to 4 inches in internal conduit diameter size (FF 358, 449). Complainant stipulated that its MINI-MAG and K-MAG flowmeters in sizes less than two inches are not made in accordance with the claims of the '982 patent. (FF 5). Therefore, the administrative law judge finds that the domestic industry consists of F&P's facilities devoted to the research, development, manufacture, marketing and servicing of the MINI-MAG and K-MAG meters in sizes two inches to four inches. (FF 448).<sup>36/ 37/</sup>

---

<sup>36/</sup> Respondents argue that because complainant failed to provide basic economic data with respect to the industry at issue, complainant has not met its burden of proof. (Tr at 2104-2105). While complainant has provided sales and profitability data with respect to MINI-MAG and K-MAG flowmeters, it has stated that it does not keep such data for flowmeters 2-4 inches in diameter. (FF 491). Given the common production facilities and employees used for the manufacture of flangeless magnetic flowmeters of all sizes by F&P, it is unlikely that profitability, employment and capacity data for the industry at issue could involve more than a simple allocation, and such an allocation would have no effect on trends. Nonetheless, complainant, through its business manager for flow products (FF 492), estimated that percent of its total sales were accounted for by the relevant flowmeters of 2-4 inches in diameter. (FF 492). Respondents' sales of flowmeters 2-4 inches in diameter accounted for between of their sales during 1983-1985. (FF 493). Furthermore, key data used by the Commission in assessing causation, such as lost sales and price competition, were available on the basis of relevant flowmeter sizes.

<sup>37/</sup> The industry definition is consistent with the definition proposed by the staff. (SPost at 10). Complainant and respondents are in agreement that the domestic industry comprises those facilities of complainant dedicated to flowmeters in sizes at least two inches in diameter. (Tr. at 2133).



C. Efficient and Economic Operation

In order to prevail under section 337, a complainant must establish that the domestic industry is efficiently and economically operated. The guidelines set forth by the Commission to assess whether a domestic industry is efficiently and economically operated include: (1) use of modern equipment and manufacturing facilities; (2) investment in research and development; (3) profitability; (4) substantial expenditures in advertising, promotion, and development of consumer goodwill; (5) effective quality control programs; and (6) incentive compensation and fringe benefit programs for employees. See e.g., Certain Methods for Extruding Plastic Tubing, Inv. 337-TA-110, 218 U.S.P.Q. 348 (1982); Certain Coin Operated Audio Visual Games and Components Thereof, Inv. 337-TA-105, 216 U.S.P.Q. 1106 (1982); Certain Slide Fastener Stringers and Machines and Components Thereof, Inv. 337-TA-85, 216 U.S.P.Q. 907 (1981).

F&P dedicates approximately                      square feet of its Warminster facility and approximately                      square feet of its Vineland, New Jersey plant to manufacture, repair and quality control activities for its MINI-MAG and K-MAG products.                      square feet of the above described facilities are dedicated to testing and calibration of these products. (FF 459). Equipment used for the manufacture, repair and quality control of F&P's MINI-MAG and K-MAG products includes a machine shop, testing equipment and flow loop calibration equipment. (FF 460).

F&P employs approximately                      people on a full time basis for the manufacture, repair and quality control for the MINI-MAG and K-MAG meters. These employees include machinists, mechanical parts assembly employees, electronic assembly employees, quality control individuals, manufacturing

engineers and product engineers. In an answer to a staff interrogatory the number of individuals so employed was put at            There is no explanation for this discrepancy. (FF 461).

F&P employs approximately            full time sales persons,            sales support persons, and            independent manufacturing representative firms. F&P has approximately 30 separate sales offices located throughout the country including regional offices located in New York, Houston, Chicago and Atlanta. (FF 464). F&P also employs            regional engineers with respect to sales, and approximately            marketing persons. The sales personnel devote approximately            percent of their time, and the marketing personnel percent of their time, to the sale and marketing of MINI-MAG and K-MAG products. (FF 465).

F&P's MINI-MAG and K-MAG flowmeters incorporate numerous electronic and mechanical components which are supplied by more than            vendors. Less than            percent of the MINI-MAG components are manufactured outside the United States. (FF 485). For the K-MAG, F&P purchases cast ceramic spools from its German subsidiary, which sources them from a German supplier. (FF 486). The proportionate value of the ceramic spool viz a viz the total cost of raw materials and components used to manufacture the K-MAG flowmeter, inclusive of labor costs and general administration expenses, is approximately percent. (FF 487). K-MAG sales represent approximately            percent of F&P's sales under the '982 patent. (FF 488, 490).<sup>38/</sup>

F&P has expended over            in tooling and associated equipment used for the design and development of the manufacturing, testing and repair

---

<sup>38/</sup> Because F&P did not break its MINI-MAG and K-MAG data into flowmeters less than 2 inches and flowmeters 2 inches and above, the foregoing and subsequent discussion relates to all MINI-MAG and K-MAG flowmeters.

processes used for the patented meters, as well as for other flowmeters. This expenditure included the purchase of die cast tooling, calibration rigs, investment casting dies and injection molding equipment, including dies and various welding fixtures. (FF 471, 476). F&P anticipates investing an additional            within the next two years to enhance the manufacturing facilities for the MINI-MAG and K-MAG meters. (FF 477).

F&P's profitability with respect to flangeless magnetic flowmeters increased from 1983 to 1984, and the ratio of net profit to sales was percent. (FF 490). F&P devotes considerable resources to research and development, quality control, repair and advertising for its MINI-MAG and K-MAG flowmeters. (FF 455-60, 466-67, 473-76).

F&P provides benefits for its employees, including group life insurance, sick pay, hospitalization, and surgical and medical benefits. F&P has a non-contributory, defined benefit compensation plan for U.S. employees that meet certain eligibility requirements. (FF 468). F&P also provides benefits such as an incentive savings plan, under which common shares of the company may be purchased by most employees. (FF 469).

F&P has had problems with procuring ceramic spools used in its K-MAG flow meter from its German subsidiary. (FF 551-60). This problem likely resulted in F&P losing certain sales to customers that preferred a ceramic spool flowmeter. (FF 504-07). However, F&P's first quarter 1986 sales of flowmeters using the ceramic spool were greater than sales of this meter during the last three quarters of 1985. (FF 490). Additionally, certain customers have been dissatisfied with F&P's service or quality, and F&P seems not to have been aggressive with respect to marketing their product to certain customers. (FF 561, 573, 578, 589, 591).

Even though certain problems have existed with respect to F&P's supply of ceramic spools and customer service, the administrative law judge finds that

this evidence is not sufficient to render a determination that F&P is inefficient or uneconomic, in light of the other evidence concerning F&P's profitability, R&D, and quality assurance.

For the above reasons, the administrative law judge finds that the domestic industry in the United States consisting of the domestic facilities of F&P devoted to the production of flangeless electromagnetic flowmeters two to four inches in diameter is efficiently and economically operated.<sup>39/</sup>

#### H. Injury

In order to prevail in a section 337 investigation, complainant F&P has the burden to establish that the subject flowmeters have ".... the effect or tendency ... to destroy or substantially injure the domestic industry ....". Injury requires proof separate and independent from proof of the unfair act. Furthermore F&P must establish all elements of section 337 if it is to prevail. Certain Centrifugal Trash Pumps Inv. 337-TA-43, 205 U.S.P.Q. 114, 117, (1979). F&P must also establish a causal relationship between respondents' alleged unfair acts and any injury to the domestic industry alleged to be the result of such acts. Certain Spring Assemblies and Components Thereof Inv. 337-TA-88, 216 U.S.P.Q. 225, 243 (1981).

#### 1. Effect to Substantially Injure<sup>40/</sup>

---

<sup>39/</sup> The staff has argued that the domestic industry is efficiently and economically operated. (SPost at 11). Respondents allege inadequate service, and product dissatisfaction which respondents state have a bearing on injury. See footnote 1 at 8.

<sup>40/</sup> Complainant argues that even though flowmeters less than two inches should not be included in the U.S. industry definition, imports of such meters  
(Footnote continued to page 81)

Complainant and the Commission investigative attorney have contended inter alia that the domestic industry has been substantially injured because:

- a. F&P's sales and profits for flangeless magnetic flowmeters have decreased from 1984 to 1985;
- b. F&P has excess capacity for the production of such flowmeters, and increasing inventories;
- c. Krohne has made substantial sales of its ALTOFLUX X-1000 and DELTAFLUX flowmeters in the United States;
- d. respondents' market share has
- e. respondents' infringing flowmeters have displaced F&P's patented meters for sales to some accounts; and
- f. respondents' have both the manufacturing and sales capacity, as well as the intention, to continue to actively compete in the U.S. market.

Respondents argue that complainant has failed to establish a causal nexus between the alleged unfair acts, and the alleged effect to substantially injure as well as the alleged tendency to substantially injure.

Thus respondents argue the absence of a nexus because there is "uncontroverted evidence" that 1) user preference is based on the "aluminum oxide [ceramic] flow tube - platinum electrode construction" of respondents'

---

(Footnote continued from page 80)

by Krohne should be included in the injury analysis because their sales in many instances lead to the loss of sales by F&P of its larger meters. (CPost at 27, 30). It is a fact that Krohne meters under two inches cannot technically be substituted for F&P flowmeters of two inches and over. (FF 510). Complainant's argument is essentially that imports of Krohne flangeless magnetic flowmeters less than two inches in diameter injure the domestic industry indirectly, by enhancing the competitiveness of Krohne's two inch and over flowmeters through a more complete product line. Therefore, any injury from Krohne flowmeters under two inches is accounted for through an analysis of any direct injury from Krohne meters two inches and over, since any such direct injury would implicitly include this enhanced competitiveness effect. Thus, to include the Krohne flowmeters less than two inches would have the effect of double-counting injury.

Independent of any economic argument, the administrative law judge has found that Krohne flowmeters under two inches do not infringe the '82 patent. (See supra at 49-52).

accused flowmeters rather than on any feature of the '982 patent (RPost at 2), 2) that complainant has lost business because of its own defective products, poor service and inadequate sales network and 3) the presence of significant non-infringing competition in the market place. (RPost at 2).

In support of their user preference argument, respondents cite the concurring opinion of Vice Chairman Alberger in Certain Centifugal Trash Pumps Inv. 337-TA-43, 205 U.S.P.Q. 114, 120-122 and Convertible Rowing Exercises, Inv. 337-TA-212 at 278-279 (1985) (unreviewed initial determination) (RPost at 3).

In Trash Pumps Commission Alberger in his concurring opinion stated:

We should not grant relief where the most attractive feature leading to the growth of importations does not reside in the patent itself. This is particularly so where other products in the market demonstrate a consumer preference for unpatented features. Id. at 121.

Commissioner Alberger relied on testimony which indicated that complainant's "clean-out features" were not a price consideration, suggesting that even pump lines which do not have the patented features outsell complainant's heavier, more costly pump. Id. at 120.

Significant to Trash Pumps is the administrative law judge's initial determination in Certain Spherical Roller Bearings, Inv. 337-TA-179 (1984) (an unreviewed initial determination that became the Commission Determination<sup>41/</sup>). In Roller Bearings the judge stated that "customer preference can only preclude a finding of injury where the preference is unrelated to the patented features of the accused product" and that in Trash Pumps, "customer preference was related to the overall weight of the pump,

---

<sup>41/</sup> Notice of Commission dated December 5, 1985.

which was totally unrelated to the claimed invention." Ia. at 88. (Emphasis added)

In the present investigation, customer preference allegedly is based on the aluminum oxide ceramic flow tube and platinum electrode construction. The administrative law judge has found that respondents' 2-4 inch ALTOFLUX and DELTAFLUX flowmeters infringe claims 1-5 of the '982 patent because they are a flangeless electromagnetic flowmeter unit encaged within a circle of bolts containing a combination of a cylindrical ferromagnetic housing having an external diameter which is smaller than that of a circle of bolt holes of end flanges of upstream and downstream pipes, a non-magnetic flow tube (spool) coaxially disposed within said housing, a pair of electromagnetic coils, and a pair of electrodes with the housing and flow tube sharing any applied compressive force caused by bolts encaging the unit to effect a fluid seal. Thus, rather than the respondents' infringing flowmeters not having the patentable features of complainant's claimed flowmeter, they contain the critical patentable features of the claimed flowmeter. While the particular electrode and particular flow tube used by respondents may be improvements over the flow tube and electrodes of the combination disclosed in the '982 patent, the improvements are not unrelated to the patented features. Rather, such improvements incorporate the patented features of the '982 patent.<sup>42/</sup> There could not be any infringing flowmeters in the absence of the patentable features of the claimed flowmeter of the '982 patent.

Moreover, while respondents appear to argue that consumer preference is not for a flangeless flowmeter, there is evidence from respondents that many customers in fact do purchase flangeless flowmeters, with compactness being a

---

<sup>42/</sup> See footnote 21 at 52.

consideration. (FF 514, 523-25, 532, 539).<sup>43/</sup> The flangeless construction which is claimed in the '982 patent does contribute to the compact size of the flangeless flowmeters. (FF 532-39). Furthermore, on the production side, the record shows that the flangeless construction contributes to lower production costs, clearly a competitive advantage for a manufacturer using such a design. (FF 541). It is a fact that Krohne decided to market a flangeless flowmeter (FF 521-22) and that it had been under consideration by Krohne for some time. (FF 532(a)). Significantly, the flangeless design is one of two factors cited by the Frost & Sullivan report having a "profound effect" on increasing market penetration throughout the 1980's. (FF 539).

With respect to respondents' argument that complainant has lost business because of its own defective products, poor service and inadequate sales network, while complainant has lost some sales due to poor service or quality problems, the record does not show that those losses were widespread, or that complainant had an unusually high return or reject rate overall. See Certain Convertible Rowing Exercises Inv. 337-TA-212 Id. at 279, (an unreviewed initial determination, as to economic issues, which became the Commission Determination).<sup>44/</sup> Anecdotal instances of sales lost due to poor service or quality exist for any supplier, and are not sufficient to offset the other evidence of injury in this investigation.

Respondents' argument concerning the existence of non-infringing substitutes focuses on the standard of proof complainant bears on the issue of

---

<sup>43/</sup> Krohne itself began discussing the concept of a flangeless magnetic flowmeter as early as 1965-1966 during discussions related to reducing the volume (the three dimensions of the flowmeter) of magnetic flowmeters. The reduction in "volume" was expected to enhance the competitiveness of the flowmeter. (FF 533(a)).

<sup>44/</sup> Notice of Commission dated December 5, 1985.



injury. The record establishes that the United States market in this investigation is complex because of the availability of several non-infringing substitute flowmeters that compete directly with those offered by complainant. (See FF 499, 508, 520). Thus, even though this is a patent based investigation, the assumption cannot be made that any share of the market covered by the '982 patent held by Krohne represents a market share that rightfully belongs only to complainant. (CPost at 33).<sup>45/</sup> Complainant bears the burden of establishing a causal nexus between the unfair act of respondents and any injury to the domestic industry and must do so without reliance on the assumption that, given its monopoly rights under the '982 patent, every sale of an infringing flowmeter is necessarily a sale that F&P would have made absent Krohne's unfair act.

(a) Domestic Industry Decline in Sales and Profits

It is apparent that the domestic industry has experienced a decline in sales and profits in 1985. (FF 490). Complainant's sales and profits increased from 1982 to 1984 with sales revenue increasing percent to million in 1984 and profits increasing by percent over the same period.<sup>46/47/</sup> (FF 490). F&P's sales revenue declined by

---

<sup>45/</sup> See Certain Vertical Milling Machines and Parts, Attachments, and Accessories Thereto Inv. 337-TA-133, 223 U.S.P.Q. 332, 348 (1984)

<sup>46/</sup> Although the domestic industry did not exist until late 1983, data for earlier years are relevant in the context of discussing trends with the issuance of the '982 patent on Dec. 20, 1983. Certain Roller Units, Inv. 337-TA-44, USITC Pub. 944, RD at 32, n.1 (1979).

<sup>47/</sup> These figures relate to F&P's flangeless magnetic flowmeters up to 4 inches in diameter, which include meters not covered by the '982 patent. F&P stated that it did not compile such data on the basis of flowmeters 2-4 inches (Footnote continued to page 86)

million, or        percent, in 1985. Profits also declined in 1985, although the ratio of net profits to sales remained at        percent. (FF 490; See FF 682).

(b) Domestic Industry Operating Well Below Capacity and Increased Inventory

F&P's production capacity for MINI-MAG flowmeters, based on one shift, was        units per year in 1985. (FF 482-84, 497). F&P produced MINI-MAG and K-MAG flangeless magnetic flowmeters in 1985, so that substantial excess capacity existed. (FF 482).

The value of F&P's year-end inventory related to MINI-MAG and K-MAG flowmeters (parts and finished goods) increased from        in 1984 to        in 1985. (FF 496).

(c) Market Share

An estimate of the market share held by Krohne flangeless magnetic flowmeters 2-4 inches in diameter is difficult in this investigation because of the complexity of the market, and the lack of data with respect to magnetic flowmeters from other suppliers in this size range.<sup>48/</sup> The Frost and

---

(Footnote continued from page 85)

in diameter, which constitutes the industry at issue. (FF 491). F&P estimated that 60 percent of their flangeless magnetic flowmeter sales were accounted for by flowmeters 2-4 inches in diameter. (FF 492).

<sup>48/</sup> Both complainant and staff compute import market shares based on F&P and Krohne aggregate sales of magnetic flowmeters between two and four inches in diameter, and arrive at import market shares of over        respectively. (CPFF 222-27; SPost at 21; SPFF 135-135(a)). However, both the staff's and complainant's market share calculations include sales of only F&P and Krohne magnetic flowmeters. Noninfringing competition also exists, and should be thus part of the "market". Therefore, an estimate of sales of competitive non-infringing magnetic flowmeters should also be included when estimating Krohne's market share. (See FF 508, 633-54).

Sullivan report provides data on the overall magnetic flowmeter market, and estimates of Krohne's market share can be made from the information on the United States magnetic flowmeter market in the report. The Frost and Sullivan report was admitted into evidence, over respondents' objections, because of respondents' specific reliance on the report for market share information in the United States after the patent issued. See Order No. 14. On the basis of the report and Krohne's sales, an estimate of the U.S. market share held by Krohne flowmeters 2-4 inches in diameter

1.9 percent in 1983 and 3.4 percent in 1984, and then declined to 2.7 percent

(FF 498(a-d)). For total unit sales by F&P and Krohne of flangeless magnetic flowmeters 2 to 4 inches in diameter, Krohne's sales represented

(FF 477).

The above market share information should not be interpreted to mean that Krohne's share of the market would have been captured by F&P in Krohne's absence. Rather, it provides some indication of Krohne's position in the overall magnetic market for meters 2 to 4 inches in diameter, and shows that Krohne's market share As discussed earlier, supra at 85, complainant must show more than the fact that Krohne holds a significant percentage of the United States magnetic flowmeter market. Complainant must show that Krohne's sales of infringing meters actually displaced F&P sales.

(d) Lost Sales

Complainant's method for analyzing lost sales consisted of cross referencing Krohne flangeless magnetic flowmeter customers during 1984-85 with F&P's MINI-MAG and K-MAG customer lists for 1982-85. On this basis,

complainant identified customers common to complainant and respondents. (See CPFF 228). According to complainant, Krohne's sales of flangeless magnetic flowmeters to these customers totaled and complainant refers to this fact when discussing displacement of F&P's patented flowmeters by respondent. (See: CPFF 229; CPost at 30).

There are several flaws with complainant's broad-brush analysis of lost sales. First, Krohne's sales to these customers include sales of flowmeters under two inches in diameter, which should not be included in the injury analysis, as discussed earlier. When an adjustment is made to include only flowmeters 2-inches and over, Krohne sold about worth of flowmeters to these customers during 1984-85. (FF 563(a)). Second, such an analysis assumes that sales made by Krohne to a common F&P customer would have gone to F&P in Krohne's absence. In a market where non-infringing competition is present, such an assumption cannot be made. See supra at 85. In establishing causation, complainant must present evidence that: 1) it lost sales to respondents rather than to non-infringing competition; and 2) respondents' sales were at the expense of complainant rather than non-infringing competitors. Complainant has met the first criteria by focusing on Krohne sales to common customers, so that any lost sales to non-infringing competition are excluded. (FF 563(a)).

To meet the second criteria, complainant need not show that a sale made by Krohne would definitely have gone to F&P in Krohne's absence. See, e.g., Rowing Exercisers at 282. Rather, complainant must show that to a particular customer where Krohne made a sale of an infringing product, F&P sold or offered for sale a comparable patented product during a comparable time period, or that the purchaser considered F&P's patented product to be an alternative source of supply to Krohne for the same application. A simple

cross-referencing of common customers is not sufficient to meet this criteria. See Vertical Milling Machines, CD at 13.

Complainant has satisfied the above criteria with respect to four customers:

(1).

In considering the purchase of Krohne magnetic flowmeters in 1983, was concerned with how well the meter could withstand abrasive materials, since different meters were being evaluated at a pilot plant for use with coal slurries. (FF 566). Prior to purchasing Krohne magnetic flowmeters in 1983, was using F&P non ceramic magnetic flowmeters, as well as other models. (FF 565). The Krohne flowmeters were not purchased as direct replacements for existing F&P flowmeters, but for use in the coal slurry application. had concluded that the ceramic flow tube (spool) was superior to non-ceramic flow tube for the coal slurry application, and bought Krohne meters without opening the purchase to bids. (FF 567). Thus, purchased ceramic flowmeters from Krohne during the 1983-1984 evaluation period. In 1985 purchased complete Krohne flowmeters. (FF 567-68).

According to testimony, Krohne flowmeters were not purchased as replacements for F&P flowmeters, but for a particular application where the ceramic spool out performed any other lining that was available to at the time. (FF 567). Regardless of whether purchased Krohne flowmeters as replacements for existing F&P flowmeters, or to meet expanding needs, the effect on F&P is the same if such purchases were at the expense of F&P. It is evident that flowmeters from F&P would have been evaluated against Krohne flowmeters for this application, as was evaluating flowmeters from several companies in addition to Krohne for the coal slurry application, and F&P was a

significant supplier to [redacted] of flangeless electromagnetic flowmeters during the evaluation period. (FF 564-66). Although a vendor of Krohne flowmeters testified that [redacted] purchased the Krohne flowmeter because of the superiority of the ceramic tube, the record is inconclusive with respect to whether an F&P TEFZEL-liner could have been used for this application when the F&P K-MAG was not available. (FF 567; See FF 505). Furthermore, [redacted] Krohne flowmeters purchased in 1985, valued at [redacted] were purchased when F&P had its K-MAG (ceramic tube) available to the market (FF 568, 568(a)). Thus [redacted] apparent basis for purchasing the Krohne meter with the ceramic tube, would not apply for purchases of these [redacted] flowmeters.

Therefore, given the evidence that [redacted] was evaluating both Krohne and F&P flowmeters for the coal slurry application, the second criteria above is met, and F&P could have made the sales that went to Krohne during the 1984-85 period. Krohne's sales to [redacted] of magnetic flowmeters, 2-4 inches in diameter, were [redacted] in 1984 and [redacted] in 1985. (FF 568).

(11).

The evidence shows that Krohne was in direct competition with F&P for sales of comparable flowmeters, for comparable uses, during comparable time periods. (FF 581-89). Purchase orders issued by [redacted] to Krohne from June 4, 1985 to September 26, 1985 were based on competitive bids. F&P, Krohne, and Rosemount had submitted bids for this order, and Krohne submitted an addendum bid. Krohne was awarded the order based on the lowest price. The F&P meters included one MINI-MAG with TEFZEL liner and one K-MAG with a ceramic spool (both remote mounted). The Krohne meters were an ALTOFLUX X-1000 meter, including two 3-inch flowmeters, and a spare 3-inch primary. The Krohne X-1000 meter was [redacted] lower-priced than the F&P M-MAG. (FF 581). In

June-July 1985, purchased from Krohne two 3-inch ALTOFLUX X-1000 flowmeters, and in August-September 1985 purchased two 2-inch ALTOFLUX X-1000 primaries.

In 1986, Krohne flowmeters were specified by an engineer to replace F&P K-MAG flowmeters because of technical problems associated with installation and calibration of the K-MAG. (FF 588). The size of these meters and the volume of sales were not specified.

Based on the fact that Krohne and F&P competed directly for sales to sales by Krohne to could have gone to F&P. The total value of these purchases was in 1985. (FF 582-83).

(iii).

In the course of purchasing flangeless magnetic flowmeters, Bailey solicits alternative bids to get comparison pricing, including prices from F&P and Krohne. On occasion, purchases Krohne flowmeters instead of F&P flowmeters for the same application, if the Krohne price is better, although according to a purchaser, prices from all suppliers are pretty much the same with a few hundred dollars difference. (FF 595). In 1983, Krohne and signed an OEM agreement whereby would market Krohne magnetic flowmeters under the Krohne label, principally for system sales. (FF 604). Krohne's prices to were lower than its average sales price for total sales. (Compare FF 596-97, 599-602 with FF 663). The OEM agreement does not preclude Krohne America from competing with for the same business. (FF 604, 604(a) 598). Therefore, respondents' argument (RRFF 33(e)) that F&P was not a viable source of supply to because F&P competed with is not valid, since Krohne itself also competed with (FF 604).

Because flowmeters from F&P are considered by \_\_\_\_\_ as viable alternatives to Krohne flowmeters for the same applications, sales made by Krohne to \_\_\_\_\_ could have gone to F&P. (See supra at 88). Krohne sold to \_\_\_\_\_ worth of flangeless magnetic flowmeters 2-4 inches in diameter in 1984, and \_\_\_\_\_ in 1985. (FF 596-97, 599-603).

(iv).

\_\_\_\_\_ purchased both F&P and Krohne flangeless magnetic flowmeters during comparable time periods, with Krohne selling its DELTAFLUX, and F&P selling its MINI-MAG. (FF 605-13). In July, 1985, Krohne's price to \_\_\_\_\_ for three 2-inch DELTAFLUX meters was \_\_\_\_\_ apiece. (FF 611). In the same month, F&P quoted \_\_\_\_\_ to \_\_\_\_\_ for its 2-inch MINI-MAG, and it appears that \_\_\_\_\_ purchased such a meter from F&P in December 1985. (Compare FF 610 and FF 613). These prices are not exactly comparable because of differences between the two meters in liner material and accuracy (DELTAFLUX: ceramic liner, 2% error; MINI-MAG: teflon liner, 1% error). (FF 509).

F&P was a viable supplier to \_\_\_\_\_ and therefore \_\_\_\_\_ could have purchased additional F&P flowmeters in the absence of Krohne. (See supra at 88). \_\_\_\_\_ purchased \_\_\_\_\_ worth of Krohne flowmeters of 2-4 inches in diameter in 1984, and \_\_\_\_\_ in 1985. (FF 605-09, 611).

Purchases by these four customers of Krohne flangeless magnetic flowmeters, 2-4 inches in diameter, totaled \_\_\_\_\_ in 1984 and \_\_\_\_\_ in 1985.<sup>49/</sup> Such purchases represented 1.2

---

<sup>49/</sup> Other F&P customers also purchased Krohne flangeless magnetic flowmeters, 2-4 inches in diameter, during 1984-85, including \_\_\_\_\_ (FF. 563(a), 570-74, 614-23, 625-30). While it is likely that F&P would have made some of these sales in the absence of Krohne, complainant provided no evidence, such as invoices or bidding reports, showing that F&P's patented flowmeter was considered a viable alternative source to Krohne's flowmeters during 1984-85, when Krohne's flowmeters were actually purchased. At least one customer, \_\_\_\_\_ testified



percent of combined Krohne and F&P sales, 2-4 inches in diameter, in 1984, and 2.2 percent in 1985. (FF 490-92).

(e). Price Competition

From direct price comparisons, there have been some instances of underselling by Krohne based on an analysis of actual bid prices at the individual customer level for the F&P K-MAG and the Krohne ALTOFLUX-1000.<sup>50/</sup>

The F&P K-MAG and the Krohne ALTOFLUX X-1000 are most comparable technically, since both have ceramic spools and their accuracy differs by 0.5 percentage point, compared to an accuracy difference of 1.0 percentage point between the K-MAG and DELTAFLUX. (FF 509).

---

(Footnote continued from page 92)  
that it has not been approached directly by F&P over the last six or seven years. (FF 573).

<sup>50/</sup> Both F&P and Krohne have list prices, but because of heavy discounting, list price comparisons reveal little concerning actual price competition. (See FF 656, 660-61, 662-63, 665, 666-67, 672). In addition, competitors selling flowmeters not covered by the '82 patent have also been aggressive with respect to pricing, and F&P has discounted heavily in competition with these other domestic suppliers. (FF 635, 642, 646-51, 672). Complainants, respondents, and staff have each estimated margins of underselling or overselling by adjusting list prices to account for discounting, technical differences, and additional costs. (See: CPFF 205-21; RPFER E11-E15; SPFF 118-30). Complainant and staff conclude that Krohne undersold F&P; respondent concludes that Krohne's flowmeters were higher priced. However, in the price analyses performed by the parties multiple assumptions were made in making adjustments to list prices. The result is that their price comparisons are unreliable. Specifically, complainant assumes a discount from F&P's list price of \_\_\_\_\_ percent for the F&P MINI-MAG and \_\_\_\_\_ percent for the F&P K-MAG. (Compare CPFF 207 and 208). However, the record shows that in competitive situations F&P often discounted between \_\_\_\_\_ percent during 1985. (FF 672-74). Staff does not factor any discount into F&P's list prices, but applies Krohne's discount multiplier to Krohne list prices. (See SPFF 118, 124-25, 129). Respondent adds a \_\_\_\_\_ installation charge for remote electronics to Krohne's price but does not add a similar installation charge to F&P's price, although the record shows that this additional charge would be incurred by customers of both complainant (in addition to the \_\_\_\_\_ charge for the remote electronics option) and respondent for a flow meter with remote electronics. (FF 668-69; See RPFER E78, E79). In short, the aggregate price analysis of each party has serious flaws. While reliable average prices for Krohne can be estimated based on unit values of actual sales, comparable data are not available for F&P. (See FF 662-63).

Direct price comparisons in the record pertain to the following. In June 1985, Krohne bid for two 3-inch ALTOFLUX X-1000's and F&P bid for a 3-inch K-MAG for quotes to (FF. 581-83). Krohne was awarded the bid on the basis of price. (FF 581).<sup>51/</sup> In an earlier bidding situation in 1984, involving Krohne's ALTOFLUX-1000 and F&P's MINI-MAG, F&P won on the basis of the lowest price. (FF/589).<sup>52/</sup> For sales to

Krohne made its sales of DELTAFLUX and ALTOFLUX X-1000 flowmeters because of lower price. (FF 595-604). solicits alternative bids to get comparative pricing, including bids from F&P, and entered into an OEM agreement with Krohne whereby purchased flowmeters, two inches and above in diameter, from Krohne during 1984-85. (FF 595, 604). Prices paid by for ALTOFLUX X-1000 flowmeters were an average of for the 2-inch, for the 3-inch, and for the 4-inch models. (FF 597, 601). These prices were approximately lower than Krohne's overall average sales prices during 1984. (Compare FF 597, 601 with FF 663).

Based on the foregoing, viz. domestic industry declines in sales and profits, the domestic industry operating well below capacity and with increased inventory, shift in market share, lost sales and price competition, the administrative law judge finds that complainant has met its burden of proof by a preponderance of evidence that the domestic industry has been substantially injured by the respondents' activities in the United States.

---

<sup>51/</sup> Few price comparisons between these two models may be explained by the fact that F&P's sales of its K-MAG began only in April 1985 and have been of significantly smaller volumes than for its MINI-MAG flow meter, which does not use a ceramic spool. (FF 490, 501).

<sup>52/</sup> However, this price comparison involves a Krohne ceramic spool flowmeter relative to F&P's TEFZEL-lined flowmeter.

(2). Tendency to Substantially Injure

When an assessment of the market in the presence of the accused imported product demonstrates relevant conditions or circumstances from which probable future injury can be inferred, a tendency to substantially injure the domestic industry has been shown. Certain Combination Locks, Inv. 337-TA-45, RD at 24 (1979). Relevant conditions or circumstances may include foreign cost advantage and production capacity, ability of the imported product to undersell complainant's product, and the potential and intent to penetrate the United States market. Certain Methods for Extruding Plastic Tubing, Inv. 337-TA-110, 218 U.S.P.Q. 248 (1982); Reclosable Plastic Bags, Inv. 337-TA-22, 192 U.S.P.Q. 674 (1977).

The legislative history of section 337 indicates that "where unfair methods and acts have resulted in conceivable loss of sales, a tendency to substantially injure such industry has been established." Trade Reform Act of 1973, Report of the House Comm. on Ways and Means, H. Rep. No. 93-571. 93 Cong. 1st Sess. at 78 (1973), citing In re Von Clemm, 108 U.S.P.Q. 371 (C.C.P.A. 1955). In discussing the legislative history of section 337 the Commission noted in Optical Waveguide Fibers, Inv. 337-TA-189, USITC Pub. 1754 (1985), that this "sentence is an apparent attempt to characterize the holding in Von Clemm, rather than a concurrent explanation of the provision relating to tendency to substantially injure. ... The majority opinion in Von Clemm did not explicitly refer to 'conceivable losses of sales' but affirmed the Commission's determination on tendency to injure which was made on the basis of ever increasing imports which undersold complainants articles" Waveguide Fibers, CD at 13, 14, n. 9.

The injury requirement has never been altered by Congress, and in fact Congress expressly rejected an attempt to eliminate this element from section

337 in the Trade Reform Act of 1973. Textron v. U.S. International Trade Commission, 753 F.2d 1019, 1029, U.S.P.Q. 625 (Fed. Cir. 1985), citing H. Kaye, et al., International Trade Practice §6.05 n.1 (1984). Although this legislative history suggests a low threshold with respect to the "tendency" language of section 337, the injury has to be a substantive and clearly foreseen threat to the future of the industry, not based on allegation, conjecture, or mere possibility. In the Matter of Certain Braiding Machines, Inv. 337-TA-130 (1983); In the Matter of Expanded Unsintered Polytetraflouroethylene in Tape Form, Inv. 337-TA-4 (1976).

Complainant has argued that where the unfair acts have resulted in a conceivable loss of sales, a tendency to substantially injure has been established, and that even in the absence of demonstrated lost sales, a tendency to substantially injure can be shown. The cases the complainant cites do not, however, support such broad statements and must be viewed in the factual context in which they arose. In Certain Surveying Devices, the Commission found lost sales and customers, a 5 percent market share by respondent, and further that respondent aggressively sought to expand its U.S. sales. 208 U.S.P.Q. at 51-52. Certain Apparatus For Continuous Production of Copper Rod, Inv. 337-TA-52, 206 U.S.P.Q. 138 (1979) involved an industry where the loss of a single sale could cause substantial injury. 206 U.S.P.Q. at 161. Such is not the case in the present investigation.

The Commission considered the issue of tendency to injure at length in Waveguide Fibers, and made clear that although the burden in an intellectual property right case is less stringent, complainant still must establish through reliable, probative, and substantial evidence of record, that a tendency to substantially injure exists. Complainant has met this burden in the present investigation.

Complainant can meet domestic requirements. (supra at ). Respondents have argued that complainant cannot meet U.S. demand for the patented article. Respondents also argue that because respondents are considering domestic production, and because complainant has so stipulated, (FF 685), that respondents' future domestically produced products could not be considered indicia of injury. (RPost at 9, 10 citing Waveguide Fibers). Waveguide Fibers does not support respondents' argument, however. That investigation involved a respondent that was actually building a domestic facility, had invested a substantial amount of money in the U.S. facility and had a current work force of over 110 people. CD at 8, 9, ID at 111, 112. The fact that Krohne is considering producing products, including those that infringe F&P's '982 patent, does not remove the threat the imported products will bring to the domestic industry. Krohne could decide for business reasons not to build a domestic facility, or might build one but not for several years. Therefore, any tentative plans by Krohne to produce the subject product in the United States bears little weight on the tendency issue.

Cost of production comparisons are not helpful in this investigation because F&P's and Krohne's cost data are on a different basis, with F&P's costs including the electronic converter, and Krohne's cost excluding it. (FF 675-78). However, profit margins at both Krohne Germany and Krohne America show that if necessary. In Jan.-Oct. 1985, Krohne Germany's gross profit (net profits not provided) was of its sales to Krohne America for ALTOFLUX X-1000 and DELTAFLUX flowmeters. (FF 682, 683).<sup>53/</sup> Krohne America's net profit was of

---

<sup>53/</sup> A problem with using gross profits as an indicator of price flexibility (Footnote continued to page 98)

its sales in 1985 for flowmeters 2-4 inches in diameter. (FF 562). For sales to an account with whom Krohne had signed an OEM agreement Krohne's prices were below its average price for overall sales, an indication of its price flexibility with respect to important accounts. (Compare FF 596-97, 599-602 with FF 663).

Respondents argue that the capacity of Krohne Germany to supply the U.S. market is limited, given its other worldwide commitments. (RPost at 14). Exports to the United States accounted for about of Krohne Germany's 1985 production, and Krohne Germany asserted that this represented the proportion of its capacity available to the United States. (Compare FF 442 and 679). Additionally, although Krohne America attempts to

(FF 680).

Although Krohne Germany may have no intention of increasing shipments to the United States, and , the record indicates that respondents have demonstrated the ability to compete effectively in the United States, and the intention to remain a factor in the United States market.

(FF 679). Krohne's ability to

---

(Footnote continued from page 97)  
is that not all costs have been taken into account. For example, in F&P's case, the net profits were about percent lower than gross profits for the K-MAG. (FF 490).

compete is demonstrated by evidence of lost sales,<sup>54/</sup> as well as the capability to continue making sales to the U.S. market. Its intention to remain a competitor in the United States is demonstrated by several factors. Respondents have a network of 35 independent sales representatives in the United States. (FF 690). Although Krohne America's shipment levels reliance on such a statistic to project future trends in imports is unreliable, especially in light of the from Krohne Germany during 1983-85 and Krohne America's inventory levels of flowmeters. (FF 442, 444, 689, 691).

For the above reasons, the administrative law judge finds that complainant has met its burden of proof by a preponderance of evidence that there is a tendency to substantially injure the domestic industry by reason of respondents' importation and sale of flangeless electromagnetic flowmeters, 2 to 4 inches in diameter.

In sum, complainant F&P has shown that there exists an effect and tendency to substantially injure the domestic industry.

---

<sup>54/</sup> The OEM agreement between Krohne & was signed on June 3, 1983. The agreement is effective for one year and is automatically renewed thereafter, unless it is terminated by either party upon written notification at least 90 days before the expiration of the current term. Thus, Krohne will continue selling to at least until June 1987. Considering its sales to in 1985 alone were almost the existence of the agreement is important in that it shows the likelihood of continued sales of the infringing meters. (FF 604(a)).

## FINDINGS OF FACT

### JURISDICTION

1. The Commission has in rem and subject matter jurisdiction in this investigation, under section 337, since the complaint alleged unfair methods of competition and unfair acts involve the importation into, and sale in, the United States of certain unitary electromagnetic flowmeters with sealed coils by reason of alleged infringement of the claims of the '982 patent, the alleged effect or tendency of which is to destroy or substantially injure an industry, alleged to be efficiently and economically operated in the United States.

2. The Commission has in personam jurisdiction over all the parties to this investigation. All parties have appeared and litigated the issues in the investigation.

### THE PARTIES AND PRODUCTS

3. Complainant, F&P is a Pennsylvania corporation having its principal place of business at 200 Witmar Road, Horsham, Pennsylvania. (CX-3).

4. F&P's business activities include the manufacture and sale of process and control instruments, equipment and systems, including maintenance services and replacement parts for measurement, recording and control of liquid and gaseous fluid flow. (CX-3).

5. F&P, under the '982 patent, sells two models of flangeless flowmeters designated by the trademarks MINI-MAG and K-MAG. The flangeless meter disclosed by the '982 patent is a more compact structure than any prior art



device whether of the flanged or flangeless design. A 4" MINI-MAG, the largest of the MINI-MAG flowmeters, weighs only 31 pounds. The closest prior art magnetic flowmeter is the 6" Mag 10D1435 (COPA-X). Complainant was selling its MINI-MAG in the United States in 1982. Complainant's MINI-MAG and K-MAG magnetic flowmeters in sizes smaller than 2 inches are not built in accordance with the '982 patent. (Riester CX-1 at 5; RX-113 at Stipulation 5; CX-72 at 00037; CX-39; FF 273; Diem CX-2 at 4; FF. 356).

6. F&P conducts administrative and manufacturing operations in the United States, Canada, Germany, France, Italy, Belgium and Mexico. (RX-42 at 4).

7. F&P leases facilities in France, England, Australia, Spain, Sweden, The Netherlands, Finland and the United States. (RX-42 at 4).

8. F&P has subsidiaries and divisions in Belgium, Austria, England, Finland, France, Federal Republic of Germany, Italy, The Netherlands, Spain, Sweden, Australia, Canada, Mexico and the United States. (RX-35 at 00423).

9. Respondents in this investigation are Krohne Messtechnik GmbH & Company KG (Krohne Messtechnik) located in Duisburg, Federal Republic of Germany and Krohne-America, Inc. (Krohne-America) Dearborn Road, Peabody, Massachusetts. (Notice of Investigation).

10. Krohne America is a wholly owned United States subsidiary of Krohne Messtechnik. (RX-113 at Stipulation 2).

11. Krohne Messtechnik and Rheometron AG (Rheometron), an affiliated company located in Basel, Switzerland, manufacture various types of flow and level instruments, including the ALTOFLUX X-1000 and DELTAFLUX magnetic flowmeters which are in issue in this investigation. (RX-113 at Stipulation 1).

12. The ALTOFLUX X-1000 and DELTAFLUX magnetic flowmeters are sold in the United States by Krohne America and independent representatives. (RX-113 at Stipulation 4).

13. The DELTAFLUX flowmeters are available in sizes 1/2", 1", 1 1/2", 2", 3" and 4" (pipe diameter conduit). The ALTOFLUX flowmeters are available in 1/10", 1/8", 1/4", 3/8" as well as in all of the Deltaflux flowmeters sizes. (Beahm, RX-1 at para. 30, See FF 381 and 382 for additional details about the DELTAFLUX AND ALTOFLUX).

14. Neither Krohne Messtechnik nor Krohne America presently maintains facilities in the United States for the production of electromagnetic flowmeters. However, for a number of business considerations, including better local control of the availability of products for the U.S. market, Krohne America is actively considering commencing domestic production of certain products, including ALTOFLUX X-1000 and DELTAFLUX magnetic flowmeters. (RX-113 at Stipulation 3).

#### THE '982 PATENT

15. The '982 patent in issue is titled "Unitary Electromagnetic Flowmeter With Sealed Coils." It issued December 20, 1983 on application Ser. No. 398,809 filed July 16, 1982 to Roy F. Schmoock. On its face it is assigned to F&P. (RX-171).

16. As disclosed in the '982 patent, Application Ser. No. 398,809 is a "division" of Ser. No. 174,609 filed August 1, 1980 and which issued as U. S. Letters Patent No. 4,358,963 (the '963 patent), Ser. No. 174,609 is a continuation-in-part of Ser. No. 75,037 filed September 12, 1979 and which issued as U. S. Letters Patent No. 4,253,340 (the '340 patent). Ser. 75,037

is a continuation-in-part of Ser. No. 811,276 filed June 29, 1977 and which issued as U. S. Letters Patent No. 4,181,018 (the '018 patent). Ser. No. 811,276 is a division of Ser. No. 771,420 filed Feb. 23, 1977 and which issued as U. S. Letters Patent No. 4,098,118 (the '118 patent). Roy F. Schmoock is the named inventor of each of the '963, '340, '018 and '118 patents, and each of the patents is assigned on its face to complainant F&P. The portion of the seventeen year term of the '982 patent subsequent to the Nov. 16, 1999 expiration date of the '963 patent has been dedicated. (RX-171; RX-165; RX-164; RX-167; RX-163; CX-83 at Bates 500960).

#### Claims of the '982 Patent

17. The '982 patent contains six product claims. Claims 1-6, read:

1. A flangeless electromagnetic flowmeter unit interposable between the end flanges of the upstream and downstream pipes of a line conducting a fluid whose flow rate is to be metered, the end flanges of the pipes having a predetermined diameter and a circle of bolt holes, said unit comprising:

A. a cylindrical metal housing having an external diameter which is smaller than that of the circle whereby when the unit is interposed between the end flanges of the pipes, the housing lies within the circle and the flanges are bridged by bolts passing through the holes to engage the unit and subject it to a compressive force effecting a fluid seal;

B. a non-magnetic spool coaxially disposed within said housing and provided with end flanges which are seated against the ends of the upstream and downstream pipes and define with said housing an internal cavity, said spool forming a fluid conduit having a longitudinal flow axis which joins the upstream and downstream pipes, said spool

having a strength sufficient to withstand the pressure of fluid flowing in the conduit and said compressive force;

C. a pair of electromagnetic coils disposed at diametrically-opposed sides of said spool to create a magnetic field whose lines of flux extend across the conduit, said coils lying on a coil axis which is normal to said flow axis; and

D. a pair of electrodes mounted on said spool at diametrically-opposed positions along an electrode axis perpendicular both to the coil axis and to the flow axis whereby the fluid which flows through the conduit intersects said lines of flux to induce a signal in said electrodes which is a function of flow rate.

2. A unit as set forth in claim 1, wherein said coils are disposed in said cavity.

3. A unit as set forth in claim 2, wherein said coils are saddle-shaped.

4. A unit as set forth in claim 3, wherein said coils conform to the curvature of the housing.

5. A unit as set forth in claim 2, wherein said cylindrical housing is formed of ferromagnetic material which joins said electromagnet coils to define a magnetic circuit therewith.

6. A flangeless electromagnetic flowmeter unit as set forth in claim 2, wherein said housing includes at least one hole into which one may pour a potting compound to embed the coils disposed in said cavity.

Only claims 1-5 are in issue in this investigation.

(RX-171, Prehearing Tr. at 111).

Disclosure of the '982 patent

18. The abstract of the '982 patent reads:

A compact electromagnetic flowmeter unit interposable between the flanged ends of upstream and downstream line pipes for metering fluid passing through the line, the

unit being subject to compression by the flanged pipe ends to effect a fluid seal. The flowmeter is constituted by a non-magnetic metal spool of high strength whose inner surface is protectively covered by an insulating liner to provide a flow conduit for the fluid. Surrounding the spool and concentric therewith is a cylindrical housing fabricated of ferromagnetic material, the housing being formed by complementary half-pieces which include end plates that join the corresponding ends of the spool to define an annular inner chamber. Mounted adjacent the inner surface of the half-pieces at diametrically-opposed positions along a coil axis normal to the longitudinal flow axis are relatively thin coils which are shaped to conform to this surface to define electromagnets. Electrodes are supported on the spool at diametrically-opposed positions along an electrode axis at right angles to the coil axis. The inner chamber is filled with a potting compound to seal in the electromagnets and the electrodes.

(RX-171).

19. Under the heading BACKGROUND OF INVENTION the '982 patent discloses that its invention relates generally to electromagnetic flowmeters, and more particularly to a flangeless flowmeter having a cylindrical housing and whose components are integrated to form a highly compact, low-cost unit that may be readily installed in a flow line between the flanged ends of the upstream and downstream pipes, the flowmeter including relatively thin electromagnetic coils which conform to the inner surface of the housing. (RX-171, col. 1, lines 19-26).

20. The '982 patent states that magnetic flowmeters such as those disclosed in U.S. Pat. No. 3,695,104, No. 3,824,856, No. 3,783,687 and No. 3,965,738, are especially adapted to measure the volumetric flow rates of fluids which present difficult handling problems, such as corrosive acids,

sewage and slurries. Because the magnetic flowmeter is free of flow obstructions, it does not tend to plug or foul. (RX-171, col. 1, lines 27-33).

21. The '982 patent discloses that in a magnetic flowmeter, an electromagnetic field is generated whose lines of flux are mutually perpendicular to the longitudinal axis of the flow tube through which the fluid to be metered is conducted and to the transverse axis along which the electrodes are located at diametrically opposed positions with respect to the tube. The flowmeter's operating principles are said to be based on Faraday's law of induction which states that the voltage induced across any conductor as it moves at right angles through a magnetic field will be proportional to the velocity of that conductor. The metered fluid is said to constitute effectively a series of fluid conductors moving through the magnetic field; the more rapid the rate of flow, the greater the instantaneous value of the voltage established at the electrodes. (RX-171, col. 1, lines 34-48).

22. The '982 patent discloses that the typical commercially-available magnetic flowmeter is provided with mounting flanges at either end thereof with the meter interposed between the upstream and downstream pipes of a fluid line, each pipe having an end flange. The mounting flanges on the meter are said to be bolted to the flanges of line pipes. It is essential that the circle of bolt holes on the mounting flanges of the meter match those on the pipe flanges. (RX-171, col. 1, lines 49-54).

23. The '982 patent discloses that in a magnetic flowmeter, the flow tube is subjected to the same fluid pressure as the line pipes; and that the flow tube must therefore be of a material and of a thickness sufficient to withstand this pressure, even though the strength of the flow tube is unrelated to its measuring function. This design factor is said to contribute significantly to the cost of a standard meter. Existing meters are said to be

made up of components that must be assembled, and are generally of substantial size and weight and quite expensive to manufacture. (RX-171, col. 1, lines 57-66).

23. In order to provide a compact and readily installable electromagnetic flowmeter whose weight and dimensions are substantially smaller than existing types, the related applications of inventor Roy F. Schmoock, the inventor named on the '982 patent, identified in finding 16 are said to disclose highly compact flangeless flowmeters which, despite their reduced volume and weight, are capable of withstanding high fluid pressures, the flowmeters operating efficiently and reliably to accurately measure flow rates. (RX-171, col. 1, lines 67-68, col. 2, lines 1-5).

24. The flangeless flowmeters disclosed in the related applications, identified in finding 16, are said in the '982 patent to be interposable between the flanged ends of upstream and downstream line pipes to meter fluid passing through the line. In one preferred embodiment it is said that the meter is constituted by a ferromagnetic ring within which a pair of electromagnetic coils is supported at opposed positions along a diametrical axis normal to the longitudinal axis of the ring, the longitudinal axis passing through the central flow passage of an annular pressure vessel which is formed of high strength insulating material and is molded within the ring to encapsulate the coils as well as a pair of electrodes disposed at diametrically-opposed positions with respect to the passage along a transverse axis at right angles to the coil axis to define a unitary structure. The unit is said to be compressible between the end flanges of the pipes by bringing bolts that pass through bore holes in the pressure vessel or which lie outside of the ring to encage the unit. (RX-171, col. 2, lines 7-25).

25. Inventor Schmoock's related '340 patent is said in the '982 patent to disclose a flangeless flowmeter interposable between the flanged ends of upstream and downstream pipes in a fluid line for metering fluid passing there through, the meter including a non-magnetic metal spool of high mechanical strength which is said to function as a flow conduit and also to render the meter capable of withstanding high compressive forces as well as fluid pressure. This non-magnetic metal spool is said to be surrounded by a ferromagnetic housing which acts as a mold for potting the inner chamber defined between the spool and the housing and thereby sealing the components contained therein. The housing is also said to serve as the magnetic flux return path for the electromagnets supported thereby. The housing of the meter in the '340 patent is said to be formed by complementary half-pieces which include end plates that join the corresponding ends of the spool to define the inner chamber. Integral with the half-pieces are said to be two magnet cores which extend at diametrically opposed positions along an axis normal to the longitudinal axis of the cylindrical housing, the cores being surrounded by coils to define solenoid-type electromagnets with two electrodes mounted on the spool at diametrically opposed positions along a transverse axis at right angles to the core axis. (RX-171, col. 2, lines 25-51).

26. Inventor Schmoock discloses in the '982 patent that his prior arrangement with a pair of cored solenoids occupying diametrically-opposed positions with respect to the longitudinal axis of the flow conduit, such as disclosed in his '340 patent, is appropriate to flowmeters having flow conduits of small diameter such as one inch but unsuitable for larger diameters - "that is, diameters of two, three and four inches and greater." (RX-171, col. 2, lines 52-64).



27. Under the heading "SUMMARY OF INVENTION" the '982 patent discloses that the main object of the invention of the '982 patent is to provide a compact and efficient electromagnetic flowmeter having a cylindrical housing concentric with a spool of a relatively large diameter to define a flow conduit, an electromagnetic field being established by a pair of thin coils disposed at diametrically opposed positions with respect to the conduit, the coils lying adjacent the inner surface of the housing and having a shape conforming thereto. (RX-171, col. 3, lines 29-37).

28. A significant feature of the invention of the '982 patent is said to be the thin coils which are either coreless or surround short cores integral with the housing. The housing is of ferromagnetic material and functions as a return magnetic path for the electromagnets. An object of the invention is to provide such a flowmeter which operates reliably and efficiently within minimal prior requirements, which meter may be manufactured at low cost and can be readily installed in a pipe line. (RX-171, col. 3, lines 38-47).

29. The '982 patent discloses, in brief, that a flowmeter, in accordance with the invention of the '982 patent, includes a non-magnetic metal spool of high mechanical strength and having end flanges with the inner surface of the spool covered by an insulating liner to provide a flow conduit for the fluid to be metered, the diameter of the conduit "being at least 2 inches." (RX-171, col. 3, lines 48-54).

30. The '982 patent discloses that surrounding the spool and concentric therewith is a cylindrical housing fabricated of ferromagnetic material and formed of complementary half-pieces which include arcuate end plates that join the corresponding end flanges of the spool to define an enclosed inner chamber. Mounted adjacent the inner surface of the half pieces at diametrically-opposed positions along a coil axis that is normal to the

longitudinal flow axis of the conduit is a pair of relatively thin electromagnetic coils which are shaped to conform to this surface. Supported on the spool at diametrically-opposed positions along an electrode axis at right angles to the coil axis is a pair of electrodes. The inner chamber is filled with a potting compound to seal the coils and the electrodes therein and thereby to provide a highly stable structure, the housing serving as a mold for this purpose. (RX-171, col. 3, lines 54-68, col. 4, lines 1-2).

31. Under the heading "DESCRIPTION OF INVENTION" there is reference in the '982 patent to FIG. 1 (a transverse section taken through a flangeless electromagnetic flowmeter in accordance with the invention, the spool thereof being omitted), FIG. 2 (a longitudinal section taken through the flowmeter) and FIG. 3 (a separate view of the spool, partly in section), which three figures are said to illustrate a flangeless flowmeter unit in accordance with the invention, the unit including a non-magnetic metallic spool of high strength, preferably fabricated on stainless steel, and having end flanges. The spool is said to be provided with an insulating liner and to act as the flow conduit for the meter with the spool having the same or a smaller inner diameter as that of the adjacent piping. The Figures, particularly Figures 2 and 3, show the spool within the housing and the spool connected to the housing. (RX-171, col. 4, lines 9-29).

32. The '982 patent discloses that the spool of the invention of the patent must be capable of withstanding not only the pressure of the fluid being metered but also the compressive force to which it is subjected which force is generated by bolts which bridge the flanges of the upstream and downstream pipes between which the unit is interposed in a fluid line. A tubular liner disposed within the spool is provided with end flanges which

overlie the end flanges of the spool. Electrodes lie on an axis which is perpendicular to the longitudinal flow axis. (RX-171, col. 4, lines 35-49).

33. The '982 patent discloses that surrounding the lined metal spool and concentric therewith is a split cylindrical housing or casing formed by complementary half-pieces, the longitudinal edges of these pieces being seam welded or otherwise joined together to complete the housing. The housing is fabricated of carbon steel or other "soft" ferromagnetic material. (RX-171, col. 4, lines 50-55).

34. Integral with the housing pieces are short magnet cores formed of the same cast steel material as the housing, the cores being at diametrically-opposed positions along a coil axis normal to longitudinal flow axis which is said to be also the axis of the cylindrical housing. The coil axis is at right angles to the electrode axis so that the axis of the meter are mutually perpendicular. The cores have an arcuate formation which follows the curvature of the housing half-pieces. Received over the cores are saddle-shaped coils which are preformed and preferably lead-shielded so that they can be slipped over the cores to form electromagnets. When excited, these electromagnets establish an electromagnetic field whose lines of flux are at right angles to the direction of fluid flow, whereby when the fluid passing through the spool intercepts this field, a voltage is induced therein which is picked up by the electrodes to generate a signal that is a function of flow rate. (RX-171, col. 4, lines 57-68, col. 5, lines 1-8).

35. The opposite ends of the split housing are supported with annular closure plates whose inner peripheries mate with the outer peripheries of end flanges of the spool to define an enclosed inner chamber in the space between the spool and the housing. (RX-171, col. 5, lines 24-28).

36. The '982 patent discloses that all parts of the meter are properly located and symmetrically disposed with respect to an axis and are held within the inner chamber when assembling the unit. A flowing potting insulating material is introduced into the inner chamber and there is produced when the material is cured, a protected, moisture-free unit capable of functioning reliably and efficiently for an indefinite period. Thus it is said that the split housing functions not only as the mechanical support for the converter assembly but it also affords the magnetic flux return path for the electromagnets. Moreover it is said that the split housing provides the means for locating the various subassemblies, spools, leads, magnet parts, etc. and not only does the housing afford a weatherproof enclosure for the meter but it also acts as a mold for potting the inner chamber. (RX-171, col. 5, lines 29-45).

37. The '982 patent discloses that the flowmeter unit is interposed between the upstream and downstream pipes of a fluid line with the pipes provided with end flanges having bolts therein to accommodate a set of bolts which bridge the flanges and encage the unit. To effect a good fluid seal, the unit is said to be subjected to a high compressive force by the bolt torque. However because of the high strength of the metal spool, the unit is said to be capable of withstanding this force. (RX-171, col. 5, lines 46-54).

38. The '982 patent discloses that while saddle-shaped coils have been shown, in practice, those coils may have a diamond or circular configuration, the coils being shaped to conform to the curvature of the housing. (RX-171, col. 6, lines 8-12).

PROSECUTION OF THE '982 PATENT

39. Serial No. 398,809 from which the '982 patent issued and which was filed on July 16, 1982 contained six original claims. (CX-83).

40. A preliminary amendment filed March 1, 1983 limited the claims to a single invention in compliance with the requirements for accelerated examination. Claims 1 to 5 were said to be directed to the single species of the invention which is illustrated and in which the housing is formed of ferromagnetic material which joins the electromagnetic coils to define a magnetic circuit therewith. (CX-83 at Bates 500944).

41. On March 1, 1983 there was filed in the Patent Office a paper titled "References In Connection With Petition For Accelerated Examination". The following patents were said to have been uncovered in a pre-examination search made preparatory to filing a petition for accelerated examination and to be deemed by the inventor Schmoock to be most closely related to the subject matter encompassed by the claims:

- A German patent 2,040,682 (1972)
- B U.S. patent 3,824,856 to Yard
- C U.S. patent 3,406,569 to Rohmann
- D U.S. patent 3,286,522 to Cushing
- E U.S. patent 3,108,474 to Sasaki et al.
- F U.S. patent 3,683,691 to Kivenson and
- G U.S. patent 3,040,571 to Kolin.

(CX-83 at Bates 500945).

42. On March 1, 1983 there was also filed in the Patent Office a "Discussion of Prior Art References." It was said that in a conventional flowmeter, the fluid to be metered is conducted through a flow tube provided with a pair of diametrically-opposed electrodes, the tube being associated with electromagnets which create a magnetic field whose lines of flux are perpendicular both to the longitudinal flow axis of the tube and the transverse axis along which the electrodes are located with the fluid passing through the tube intersecting the magnetic field to induce a signal in the electrodes which is a function of the flow rate. It is said that in order to interpose the flowmeter between the flanged upstream and downstream pipes of the line carrying the fluid, the conventional flowmeter is provided with mounting flanges at either ends thereof which are bolted to the corresponding end flanges of the pipes. It is further said that because the flow tube is subjected to the same fluid pressure as the line pipes, it is essential that the flow tube be made of a material in a thickness sufficient to withstand this pressure, even though the mechanical strength of the flow tube is unrelated to its function. This is said to result in a flowmeter structure which is of substantial size and weight and to be quite expensive to manufacture. (CX-83 at Bates 500946, 500947).

43. In the "Discussion of Prior Art References" it is stated that in order to provide a highly compact and readily installable flowmeter whose weight and dimensions are substantially smaller than the existing types, the invention in what became the '82 patent provides a meter which is flangeless, yet capable of withstanding high fluid pressure. In said meter, a cylindrical housing was said to be provided whose diameter is smaller than the circle of bolt holes on the end flanges of the upstream and downstream pipes. This

cylindrical housing is said to have no flanges and in order to interpose the flowmeter between the line pipes, the end flanges of the pipes are said to be bridged by bolts passing through the holes to engage the unit and subject it to a compressive force effecting a fluid seal. Coaxially disposed with the cylindrical housing is said to be a non-magnetic spool provided with end flanges to define with said housing an internal cavity. It is said that the claims further specify that the spool which acts as the flow conduit has a strength sufficient to withstand the pressure of fluid flowing in the conduit and said compressive force. Thus it is said that the spool in the arrangement not only must be able to hold up under the pressure of the fluid conducted thereby, but it also must be able to take the compressive force applied by the bolts which surround the cylindrical housing, which force serves to prevent leakage of fluid in the region where the ends of the spool are seated against the ends of the pipes. (CX-83 at Bates 500947, 500948).

44. In the "Discussion of Prior Art References" the closest prior art reference is said to be German patent 2,040,682 which is said to show a pipe-shaped electromagnetic flowmeter interposed between the end flanges of upstream and downstream pipes and while mounting bolts are not shown, it is presumed that in this arrangement, such bolts are provided to bridge the end flanges of the pipes to engage the flowmeter therein. In the German structure it is argued that there is no cylindrical housing, and there is no flanged spool coaxially disposed therein in the manner of the invention in issue and that on the contrary, the flow tube is defined by a synthetic plastic body formed in the shape of a pipe within which is embedded electromagnetic coils and shields. Thus it is argued that in the German arrangement, the fluid pressure as well as the compressive force of the bolts is applied to the plastic body; that while such material may be able to withstand low level

fluid pressure and compressive forces, it lacks the strength afforded by applicant's (patentee's) arrangement of a cylindrical housing and a flanged spool coaxially disposed thereon; and that in the arrangement in issue, it is not the plastic potting compound which is stressed but the ends of the cylindrical housing and spool. (CX-83 at Bates 500948, 500949).

45. Yard U.S. patent 3,824,856 is said to be cited because it shows an electromagnetic flowmeter having a flow tube disposed coaxially within an outer cylindrical casing to define a cavity there between in which electromagnetic coils are embedded by a potting compound. In this reference it is said that the casing is provided with mounting flanges which are bolted to the end flanges of the inlet and outlet line pipes and hence a flangeless flowmeter is said to be not disclosed in the Yard reference wherein the flowmeter is engaged between bolts bridging the end flanges of the line pipes in the manner of the invention in issue in the application. (CX-83 at Bates 500949).

46. In the cited Rohmann U.S. patent 3,406,569 it is said that the magnetic flowmeter takes the form of a plastic flow tube in which electromagnets are embedded, the tube being inserted in a pipe section and being held therein by a mounting flange sandwiched between there end flanges of the pipes. (CX-83 at Bates 500949).

47. The cited Cushing U.S. patent 3,286,522 is said to show only a conventional mounting arrangement in which the flow tube is provided with mounting flanges which are bolted to the end flanges of upstream and downstream pipes. (CX-83 at Bates 500950).

48. The cited Sasaki et al U.S. patent 3,108,474 is said to show an electromagnetic flowmeter in which the coils are embedded in a molding disposed within an outer tube. An inner tube is said to be provided with



mounting flanges which is said to be not shown present arrangement in issue in which the outer cylindrical housing is flangeless. (CX-83 at Bates 500950).

49. The cited Kivenson U.S. patent 3,040,571 is said to show only a flowmeter provided with mounting flanges for interposition between pipes which is said also to be shown in Kolin U.S. patent 3,040,571. (CX-83 at Bates 500950).

50. In an April 1983 Patent Office action, claims were rejected under a judicially created doctrine of obviousness-type double patenting as being unpatentable over claim 1 of the applicant's U.S. patent no. 4,358,963. ('963 patent). It was said that although the claims were not identical, they were not patentably distinct from each other because the differences there between were notoriously well known to one of ordinary skill in the art as evidenced by the teachings of the prior art cited by the examiner during the prosecution of the "parent application" (which resulted in the '963 patent). It was said that a timely filed terminal disclaimer in compliance with 37 CFR 1.321(b) would overcome a rejection on this ground. Mannherz at al U.S. patent no. 3,695,104, Yard U.S. patent no. 3,824,856 and German publication 2,040,682 were said by the examiner to have been cited during the prosecution of the "parent application." (CX-83 at Bates 500955, 500956).

51. On May 24, 1983 there was filed in the Patent Office a terminal disclaimer to obviate a double patenting rejection over the commonly owned '963 patent. In the disclaimer it was said that it is agreed that any patent granted on Ser. No. 398,809 shall be enforceable only for and during such period that the legal title to said patent shall be the same as the legal title to the '963 patent. (CX-83 at Bates 500960).

52. In an amendment filed May 24, 1983 in the Patent Office, claim 1 of the application was rewritten to read substantially as claim 1 of the '982 patent. With respect to a contention of the examiner raised in the April, 1983 Patent Office action that Ser. No. 398,809, which had been identified as a division of Ser. No. 174,609 (the '963 patent) by the attorney prosecuting the application, should be called "a continuation application," applicant (patentee) disagreed. It was argued that while by definition (MPEP 201.07), "a continuation is a second application for the same invention claimed in a prior application . . . ", the claims in Ser. No. 398,809 were not directed to the same invention claimed in Ser. No. 174,609 but rather the claims of Ser, No. 398,809 were drawn to subject matter that is "distinct" from the subject matter in Ser. No. 174,609 and hence Ser. No. 398,809 was said to qualify under MPEP 201.06 as a division. A Notice of Allowance subsequently issued. (CX-83 at Bates 500962, 500963, 500964).

53. On September 7, 1983 there was filed an amendment under 37 CFR 1.312 in which it was said that in order to avoid possible confusion with "the end flanges of the upstream and downstream pipes" as recited in the preamble of claim 1 as well as in clause A of claim 1, the term "end flanges, which appeared in clause B in connection with the non-magnetic spool, had been changed to read - - end faces - -. The amendment was entered and the '982 patent issued on December 20, 1986. (CX-83 at Bates 500967, 500968; RX-171).

#### RELATED PATENTS AND APPLICATIONS

54. U. S. patent no. 4,497,212 (the '212 patent) issued on Feb. 5, 1985 to Roy F. Schmoock from application Ser. No. 536,275 which was filed

September 27, 1983 in the Patent Office. The '212 patent is argued on its face to complainant F&P. The '212 patent contains two claims. These claims read:

1. A flangeless electromagnetic flowmeter unit interposable between the end flanges of the upstream and downstream pipes of a line conducting a fluid whose flow rate is to be metered, the end flanges of the pipes having a predetermined diameter and a circle of bolt holes, said unit comprising:

A. a cylindrical housing having a predetermined length and an external diameter which is uniform throughout its length and is smaller than that of the circle whereby when the unit is interposed between the end flanges of the pipes with the ends of the housing abutting these end flanges, the housing lies within the circle and the flanges are bridged by bolts passing through the holes to engage the unit and subject it to a compressive force effecting a fluid seal;

B. a non-magnetic spool having substantially the same length coaxially supported within said housing and provided with end faces which abut the end flanges of the pipes to define with said housing an internal cavity, said spool forming a fluid conduit having a longitudinal flow axis which joins the upstream and downstream pipes, said spool having a strength sufficient to withstand the pressure of fluid flowing in the conduit;

C. a pair of electromagnet coils disposed at diametrically-opposed sides of said spool to create a magnetic field whose lines of flux extend across the conduit, said coils lying on a coil axis which is normal to said flow axis;

D. a pair of electrodes mounted on said spool at diametrically-opposed positions along an electrode axis perpendicular both to the coil axis and

to the flow axis whereby the fluid which flows through the conduit intersects and lines of flux to induce a signal in said electrodes which is a function of flow rate; and

E. a strap of ferromagnetic material joining the electromagnetic coils to define a magnetic circuit therewith.

2. A flowmeter as set forth in claim 1, wherein said coils have a saddle-shaped formation.

(RX-171; CX-103).

55. References cited in the application which led to the issuance of the '212 patent were Mannherz et al patent no. 3,695,104, Yard U.S. patent no. 3,824,856, German document 2,040,682 and British Sybron patent 1,424,875. The same primary examiner was involved in the issuance of the '212 patent and of the '982 patent. (RX-171; CX-103).

56. Ser. No. 536,275 from which the '212 patent issued is a division of Ser. No. 398,809 from which the '982 patent issued which is the patent in issue in this investigation. (RX-171; CX-103).

57. In the prosecution of Ser. No. 536,275, the examiner in an office action dated February 24, 1984 rejected the claimed subject matter under the doctrine of obviousness-type double patenting as being unpatentable over claim 3 of the '982 patent in view of British Sybron patent 1,424,875. It was said that at the time the invention as made, it would have been obvious to employ a strap of ferromagnetic material to join the coils of the device claimed in the '982 patent, especially in view of Sybron. The obviousness-type double patenting rejection was said to be a judicially established doctrine based upon public policy and to be primarily intended to prevent prolongation of a monopoly by prohibiting claims in a second patent not patentably distinct from

claims in a first patent. A timely filed terminal disclaimer, it was said, would overcome a rejection on this ground. The claimed subject matter was further rejected under 35 U.S.C. 102(b) as being clearly anticipated by the British Sybron (Fig. 7) patent. (CX-104).

58. In remarks responsive to the February 24, 1984 Patent Office action it was argued that that claim 1 of Ser. No. 536,275 called for a cylindrical housing of a predetermined length, with the ends of the housing abutting the end flanges of the unstream and downstream pipes and further specified that the spool coaxially disposed in the housing had the same length and was provided with end faces which abut the end flanges of the pipes. It was further argued that when, the bolts which join the end flanges of the pipes are tightened to compress the unit to avoid any fluid leakage therefrom, this action subjecting both the spool with cylindrical housing to "a compressive force effecting a fluid seal" (claim 1). Thus it is said that the compressive force is shared by both the housing and the spool with the spool and the cylindrical housing being the same length and engaged by the end flanges of the pipes. In Sybron, it is said that if the metal cover therein is regarded as equivalent to what is claimed in Ser. No. 536,275, the cover is not engaged by the end flanges of the pipes; and that to the contrary the end flanges of the pipes only engage the ceramic flanges in the Sybron unit (Fig. 3) of the ceramic flow tube whose flow function is similar to the spool of the unit in Ser. No. 536,275. It is concluded that when, in Sybron, the bolts are tightened, they act to squeeze the ceramic flanges between the pipe flanges and the ends of the metal cover, thereby possibly fracturing these ceramic flanges; and that there is no distribution of the compressive load between the

cylindrical housing and the spool in the manner of the invention of Ser. No. 536,275; that the greater the compressive force in Sybron, the greater the likelihood of cracking the flanges of the Sybron porcelain flow tube, for the metal cover only promotes such cracking and does not cooperate with the tube to resist the compressive force. (CX-104).

59. In the prosecution of Ser. No. 536,275 on May 1, 1984 there was filed a terminal disclaimer to obviate the double patenting rejection. In the terminal disclaimer it was agreed that any patent so granted on Ser. No. 536,275 shall be enforceable only for and during such period that the legal title to said patent shall be the same as the legal title to the '982 patent in issue in this investigation. (CX-104).

60. A Notice of allowance in Ser. No. 536,275 issued on June 20, 1984 and the '212 patent issued on February 5, 1985. (RX-171; CX-104).

61. Ser. No. 398,809, from which the '982 patent issued which patent is in issue in this investigation, is a division of Ser. No. 174,609 which was filed in the Patent Office on August 1, 1980 and from which U.S. patent no. 4,358,963 (the '963 patent) issued. The '963 patent issued on November 16, 1982 to Roy F. Schmooch and contains seven claims. These claims read:

1. An electromagnetic flowmeter unit interposable between the flanged ends of upstream and downstream pipes in a line carrying a fluid whose flow rate is to be measured, the flanged ends being bridged by bolts which engage the unit and subject it to a compressive force to effect a fluid seal said unit comprising.

- A. a non-magnetic metal spool having end flanges to provide flow conduit having a longitudinal flow axis, said spool having a strength sufficient to withstand the pressure of the fluid and said compressive force.

B. an insulating inner liner for said good.

C. a cylindrical housing formed of ferromagnetic material surrounding said spool and concentric therewith, said housing having end plates mating with the flanges of the spool to create an annular inner chamber between the spool and the housing.

D. a pair of thin coils in said chamber adjacent the inner surface of the housing at diametrically-opposed positions with respect to said flow conduit, said coils surrounding a coil axis intersecting said flow axis at right angles thereto and

E. a pair of electrodes mounted on said spool at diametrically-opposed positions along an electrode axis which is perpendicular both to the flow axis and the coil axis, said inner chamber being filled with a potting compound to seal said coils and said electrodes therein.

2. A unit as set forth in claim 1, wherein said liner is injection method of plastic material and has end flanges which overlie the end flanges of the spool.

3. A unit as set forth in claim 1, wherein said coils have a saddle-shaped form and are symmetrically disposed with respect to the coil axis.

4. A unit as set forth in claim 3, wherein said coils are received on saddle-shaped short cores integral with said housing.

5. A unit as set forth in claim 1, wherein said housing is formed of complementary half pieces which are joined together.

6. A unit as set forth in claim 1, wherein said spool is made of stainless steel.

7. A unit as set forth in claim 1, wherein said housing is made of carbon steel.

(RX-171; RX-165).

62. References cited in the application which led to the issuance of the '963 patent were Mannherz et al U.S. patent no. 3,695,104, Yard U.S. patent no. 3,824,856 and German document 2,040,682. The same primary examiner was involved in the issuance of the '963 and '982 patents. (RX-171, RX-165).

63. Ser. No. 174,609, from which the '963 patent issued, is a continuation-in-part of Ser. No. 75,037 which was filed in the Patent Office on September 12, 1979 and from which U.S. patent no. 4,253,340 (the '340 patent) issued. The '340 patent issued on March 3, 1981 to Roy F. Schmoock and contains twelve claims. These claims read:

1. An electromagnetic flowmeter unit interposable between the flanged ends of upstream and downstream pipes in a line carrying a fluid whose flow rate is to be measured, the flanged ends being bridged by bolts which subject the unit to a compressive force to effect a fluid seal, said unit comprising:

A. a non-magnetic metal spool to provide a flow conduit, said spool having a strength sufficient to withstand the pressure of the fluid and said compressive force, said spool having end flanges;

B. an insulating liner for said spool;

C. a cylindrical housing formed of ferromagnetic material surrounding said spool and concentric therewith, said housing having integral therewith at least two magnet cores of the same material which are disposed at diametrically-opposed positions along an axis normal to and intersecting the longitudinal flow axis of the spool, said housing mating with the flanges of the spool to create an inner chamber between the spool and the housing;

D. coils surrounding said cores to define a pair of electromagnets; and

E. a pair of electrodes mounted on said spool at diametrically-opposed positions along an axis which is perpendicular both to the flow axis and the core axis.



2. A unit as set forth in claim 1, wherein said liner is injection molded of plastic material and has end flanges which overlies the end flanges of the spool.
3. A unit as set forth in claim 2, wherein said liner is provided with sockets to receive and insulate said electrodes.
4. A flowmeter as set forth in claim 1, wherein said chamber is filled with a potting compound to encapsulate said electrodes and said electromagnets.
5. A flowmeter as set forth in claim 1, wherein said spool is fabricated of stainless steel.
6. A flowmeter as set forth in claim 1, wherein said spool is fabricated of stainless steel.
7. A flowmeter as set forth in claim 1, wherein the free ends of said cores are received in wells formed in said spool to focus the flux, minimize the reluctance of the flux path and trap said spool within said housing.
8. A flowmeter as set forth in claim 1, wherein said housing is of split construction and is defined by complementary half pieces.
9. A flowmeter as set forth in claim 8, wherein said half pieces are provided with edge surfaces which are joined together.
10. A flowmeter as set forth in claim 9, wherein one of said half pieces has integral therewith a platform to support a converter assembly.
11. A flowmeter as set forth in claim 1, wherein the unit is provided with longitudinally-extending bores to accommodate said bolts.
12. An electromagnetic flowmeter unit interposable between the flanged ends of upstream and downstream pipes in a line carrying a fluid whose flow rate is to be measured, the flanged ends being bridged by bolts which subject the unit to a compressive force to effect a fluid seal, said unit comprising:

A. a non-magnetic metal spool to provide a flow conduit, said spool having a strength sufficient to withstand the pressure of the fluid and said compressive force, said spool having end flanges;

B. an insulating liner for said spool;

C. a cylindrical housing formed of ferromagnetic material surrounding said spool and concentric therewith, said housing mating with the flanges of the spool to create an inner chamber between the spool and the housing;

D. electromagnets disposed within said inner chamber at diametrically-opposed positions along a field axis normal to and intersecting the longitudinal flow axis of the spool, and

E. a pair of electrodes mounted on said spool at diametrically-opposed positions along an axis which is perpendicular both to the flow axis and the field axis, said chamber being filled with a potting compound to encapsulate said electrodes and said electromagnets.

(RX-171; RX-164).

64. References cited in the examination of the application which led to the '340 patent were Wads U.S. patent no. 3,490,282, Birnsting U.S. patent no. 3,504,541, Mannherz et al. U.S. patent no. 3,745,824, Yard U.S. patent no. 3,824,856, Vidmantas U.S. patent no. 3,981,190, Ackermann et al. patent no. 4,065,965 and German document 2,040,682. The same primary examiner was involved in the issuance of the '340 patent, the '963 patent and the '982 patent. (RX-171; RX-164).

65. Ser. No. 75,037 from which the '340 patent issued is a continuation-in-part of Ser. No. 811,276 which was filed in the Patent Office on June 29, 1977 and from which U.S. patent no. 4,181,018 ('018 patent)

issued. The '018 patent issued to Roy F. Schmoock and contains four claims.

These claims read:

1. An electromagnetic flowmeter unit comprising:
  - A. An annular pressure vessel molded of insulation material to define a central flow passage having a longitudinal axis, said vessel being molded about an insulating shell which lines said passage, said shell being reinforced by a non-magnetic reinforcing spool surrounding said shell;
  - B. A pair of electromagnets embedded in said vessel at diametrically-opposed positions with respect to said passage, each electromagnet having a coil wound about a ferromagnetic core which lies along a diametrical axis extending at right angles to said longitudinal axis;
  - C. a pair of electrodes embedded in said pressure vessel at diametrically-opposed positions with respect to said passage, said electrodes lying along a transverse axis at right angles both to said diametrical and to said longitudinal axis; and
  - D. a ferromagnetic strap embedded in said vessel and interconnecting the outer ends of said cores to provide a magnetic return path therefor.
2. A unit as set forth in claim 1, wherein said shell includes a pair of diametrically-opposed sockets for receiving said electrodes.
3. A unit as set forth in claim 2, wherein said shell further includes end flanges.
4. A flowmeter unit as set forth in claim 1, wherein said spool is of non-magnetic material selected from the class consisting of steel and brass.

(RX-171; RX-167).

66. References cited in the examination of the application which led to the '340 patent were Wads U.S. patent no. 3,490,282, Funfstuck U.S. 3,636,764, Mannherz U.S. patent no. 3,745,824, Yard U.S. patent no. 3,824,856, Vidmantas U.S. patent no. 3,981,190, Ackermann et al U.S. patent no. 4,065,965 and German document 2,040,682. (RX-171; RX-167).

67. Ser. No. 811,276 from which the '018 patent issued is a division of Ser. No. 721,420 which was filed in the Patent Office on Feb. 23, 1977 and from which U.S. patent no. 4,098,118 patent (the '118 patent) issued. The '118 patent issued to Roy F. Schmoock and contains fourteen claims. These claims read:

1. An electromagnetic flowmeter unit comprising:

A. a cylindrical ring of ferromagnetic material.

B. a pair of electromagnets each having a coil wound about a ferromagnetic core attached at one end to the ring, the electromagnets being positioned with their cores extending along a diametrical axis at right angles to the longitudinal axis of the ring, the ring acting as a magnetic return path with respect to the electromagnets;

C. an annular pressure vessel formed of insulating material molded within the ring and having a central flow passage through which the longitudinal flow axis extends, said vessel encapsulating the electromagnets, said ring also acting to reinforce said pressure vessel, and

D a pair of electrodes embedded in said pressure vessel at diametrically-opposed positions with respect to said flow passage along a transverse axis which is perpendicular both to said diametrical axis and to said longitudinal axis

2. A flowmeter unit as set forth in claim 1, wherein, said cores and said ring are both made of cold rolled steel.
3. A flowmeter unit as set forth in claim 1, wherein said vessel has bores formed therein to receive bolts which bridge the end flanges of line pipes between which the unit is interposed.
4. A unit as set forth in claim 3, wherein said bores are defined by tubes embedded in said pressure vessel.
5. A unit as set forth in claim 1, wherein said electrodes are supported within sockets in a plastic spool-shaped shell which is concentric with the ring to define said flow passage and which forms a mold with said ring for said vessel.
6. A unit as set forth in claim 5, wherein said shell is provided with end flanges which are flush with the ends of the ring.
7. A unit as set forth in claim 1, wherein said electrodes have a planar formation of relatively large area.
8. A unit as set forth in claim 7, wherein said electromagnets have a rectangular cross-section to produce lines of flux within a region coextensive with said electrodes.
9. A unit as set forth in claim 8, further including shielding electrodes embedded in said pressure vessel behind said detecting electrodes.
10. A unit as set forth in claim 1, further including a preamplifier embedded in said vessel and connected to said electrodes.
11. A unit as set forth in claim 1, further including a drive circuit for said coils embedded in said pressure vessel.
12. A unit as set forth in claim 1, wherein said insulating material is an epoxy resin that adheres to said ring to form a unitary structure.
13. A flowmeter unit as set forth in claim 1, wherein said electrodes are so embedded in said pressure vessel as to have their faces in contact with the fluid passing through said passage.

14. A flowmeter unit as set forth in claim 1, wherein said electrodes are so embedded in said pressure vessel as to have their faces dielectrically-insulated from the fluid passing through said passage.

Figure 8, of the '118 patent illustrates the manner in which the flowmeter unit is compression mounted between flanges of line pipes by budging bolts which act to encage the unit. It is said that no use is made in this mounting of the bore holes in the pressure vessel. (RX-171; RX-163, col. 7, lines 27-51, 1-50).

68. References cited in the examination of the application which led to the issuance of the '118 patent were Wads U.S. patent no. 3,490,282, Appel et al. 3,999,443 German document 2,040,682 and British document 1,072,521. The '118 patent discloses that saddle-shaped magnetic coils fitted on opposite sides of the inner surface of the meter body have been used prior art commercial eletromagnetic flowmeters. The same primary examiner was involved in the issuance of the '118 patent, '018 patent, '340 patent, '963 patent, '982 patent and '212 patent. (RX-171; RX-163, col. 1, lines 46-50).

69. Each of the '982 patent, '212 patent, '963 patent, '340 patent, '018 patent and '118 patent is assigned on its face to F&P. (RX-171; CX-103; RX-165; RX-164; RX-167 and RX-163).

70. In a British patent office action dated January 4, 1983 regarding British F&P patent application no. 8,002,221 it appeared to the British patent examiner that at least certain claims of the British F&P application did not involve an inventive step having regard to the matter contained in patent specification Sybron British 1,424,875 inter alia. It was said that in the Sybron reference, the reference appeared to be directed to overcoming the same problems as those of the F&P British application, namely those associated with

inserting a flowmeter unit in a pipeline; that this was achieved by using a mechanically strong flanged ceramic tube mating with a stainless steel, housing to form a cavity enclosing the coils and the electrodes of the unit; that the invention of claim 1 of the British F&P application differed from the prior specification by substitution of the ceramic tube with a metallic non-magnetic tube provided with an insulating liner and the provision of the magnetic cores integral with the housing. It was said that such features would appear to be conventional as shown in other cited prior art specifications. It was also said that replacement of the ceramic tube of the Sybron specification by the conventional flanged metallic non-metallic non-metallic pipe and potting the electromagnet components would prima facie appear to be obvious in the light of the disclosure of other cited prior art specifications. In a later British patent office action dated September 26, 1983 reference was made to amendments filed up to and including July 4, 1983. No reference to the Sybron British patent was made in this officed action. (RX-155; RX-157).

71. In an Australian patent office dated February 23, 1983 regarding F&P Australian patent application 58603/80 it was said that the claimed invention in the Australian F&P patent application was not novel in the light of British Sybron 1,424,875 inter alia. It was said that the each of the cited prior art references differs in some way from what is claimed, e.g. the manner of connection of the flowmeter into the pipeline, the form and construction of the electromagnets, the material of which the flowmeter passage is made and the use of potting material. However it was not considered that these differences made a substantial contribution to the working of the claimed F&P device and consequently the invention claimed in the F&P application was said

to be not novel. It was said that the main consideration with which the F&P claimed invention appeared to be concerned with was the provision of an effective seal between the pipeline and the meter and the construction of the meter to withstand the forces exerted thereby and by the pressure of the liquid and that this is achieved in each of the cited prior art references. (RX-156).

72. In an Australian patent office action dated October 28, 1983, it was said that the invention as claimed is prior published by, and not novel in the light of, the British Sybron patent; that the Sybron patent (figures 3 and 7) discloses a non-magnetic tube provided with end flanges and surrounded by a cylindrical metal housing (figures 1 and 7); and that in figure 7 it is shown clamped between pipe flanges in the same way as claimed in the F&P Australian application. It is said that the F&P attorney argued that the F&P Australian invention is distinguished in that sealing is obtained by direct contact between the spool and the pipe flanges but yet according to the F&P description sealing gaskets may be used and hence it appeared that the absence of such gaskets, which are shown in figure 7 of the Sybron patent, was not considered an essential feature of the invention. In any case, it was said that it appeared that, even without such gaskets, most of the sealing would be effected by the end flanges of the liner of the F&P Australian application rather than by direct contact with the spool. Finally it was said that it was noted that the F&P Australian invention would appear to be distinguished from the Sybron British patent in that in the F&P invention the interior and both end flanges of the spool are covered with a continuous insulating liner which is provided with sockets to house the sensing electrodes.



73. The Australian patent office dated March 14, 1984 stated that the objection on the Sybron British patent is maintained; that the stainless steel cover of the Sybron reference is a cylindrical metal housing and in fact appeared to be identical to the construction disclosed in the F&P Australian application; that the flanged ceramic tube of the Sybron patent is a non-magnetic spool and is disposed within the cylindrical cover; that according to the description of the F&P application the spool rather than the metal housing is subject to the compressive forces, and that this would also be the case in the Sybron reference; and that the ceramic tubes of the Sybron reference are said to be mechanically quite strong and readily adapted to being clamped in the manner claimed in the F&P application and thus that it appeared that they are sufficiently strong to withstand the forces to which they are subjected. (RX-159).

74. On May 9, 1984, in responding to the Australian patent examiner's March 14, 1984 action, it was argued that the F&P claimed invention in the F&P Australian application can be distinguished from the the unit in the Sybron reference; that in the F&P unit the ends of the metal housing engage the end flanges of the upstream and downstream pipes and hence that when these flanges are bridged by bolts, the resultant compressive force is imposed on the ends of the housing to effect a fluid seal; that this feature is important for when the bolts are tightened to effect a seal with respect to a pressurized fluid being metered, the resultant compressive force is considerable and the metal housing must be capable of withstanding this force; that the F&P Australian claim further specified that the length of the non-magnetic spool through which the fluid flows is the same as that of the housing and hence the compressive force is also imposed on the spool which must have a strength

sufficient to withstand this force as well as the pressure of the fluid and that accordingly the compressive force is shared by the spool and the housing. It was said that the Australian examiner was quite right in noting that in the Sybron reference a steel cover is doubtless as strong as the F&P's metal housing but it was argued that the Sybron steel cover is shorter than the ceramic tube of the Sybron reference "fabricated out of porcelain just as large ceramic electrical insulators are made." (col. 2, lines 122 to 124 of the British Sybron patent). The tube in the Sybron patent is said to be provided at its ends with ceramic flanges and when the bolts are tightened, these ceramic flanges were said to be subjected to a high compressive force, the pipe flanges then pressing the ceramic flanges against the ends of the steel cover. This compressive force is said not to be shared by the cover in the Sybron patent. (RX-160).

75. F&P in a letter dated November 5, 1985 to the Australian patent office substantially repeated the arguments made in May 9, 1984 letter. (RX-160, RX-161).

76. Claim 1 inserted in the F&P Australian patent application by letter dated November 5, 1985 read:

1. A flangeless electromagnetic flowmeter unit interposable between the end flanges of the upstream and downstream pipes of a line conducting a fluid whose flow rate is to be metered, the end flanges of the pipes having a predetermined diameter and a circle of bolt holes, said unit comprising:

A. a cylindrical metal housing having a predetermined length and an external diameter which is smaller than that of the circle whereby when the unit is interposed between the end flanges of the pipes, the housing lies within the circle with the ends

of the housing engaging the flanges and the flanges are bridged by bolts passing through the holes to engage the unit and subject it to a compressive force which is imposed on the ends of the housing to effect a fluid seal;

B. a non-magnetic spool coaxially disposed within said housing and having the same length and provided with end flanges which are seated against the ends of the upstream and downstream pipes and define with said housing a internal cavity, said spool forming a fluid conduit having a longitudinal flow axis which joins the upstream and downstream pipes, said spool having a strength sufficient to withstand the pressure of fluid flowing in the conduit and said compressive force;

C. an insulating liner for said spool having end flanges which overlie the end flanges of the spool;

D. a pair of electromagnet coils disposed at diametrically-opposed positions on said spool to create a magnetic field whose lines of flux extend across the conduit, said coils lying on a coil axis which is normal to said flow axis.

. . . . .

(RX-161).

PRIOR ART

British Sybron Patent 1,424,875

77. Sybron British patent 1,424,875 was published on February 11, 1976 which is about a year before inventor Schmoock's Ser. No. 771,420 was filed on Feb. 23, 1977 (the '118 patent) (RX-172). It was filed in the British patent office on May 2, 1973. A convention U.S. application Ser. No. 264,053 was filed in the United States patent office on June 19, 1972. (RX-172). There

is nothing in the record to show that a U.S. patent issued from the U.S. application.

78. The invention in the Sybron patent is said to relate to an electromagnetic flow transducer (flowmeter) comprising a tube through which flows a conductive liquid transverse to the direction of a magnetic field in the tube, thereby producing voltages in the liquid which are a function of the volumetric rate of flow through the tube. It is said that known transducers of this kind have tubes made of various materials and in various forms chosen to provide, for instance, good resistance to attack by the material flowing through the tube, adaptability to insertion into the flow to be measured or electrical and magnetic properties relevant to the problem of detecting the flow-induced voltages and creating the magnetic fluid in the tube. Stainless steel, ceramics, plastics, glass and fibre glass are said to have been proposed for use in such transducer tubes or in conjunction therewith. The invention of the Sybron patent is said to provide a ceramic tube suitable both for general use and for specialized uses. (RX-172, at 1, lines 11-32).

79. The British Sybron patent discloses that in accordance with its invention there is provided an electromagnetic flow transducer comprising a substantially tight circularly cylindrical ceramic tube, the end regions of which are each provided with a flange, each flange being integral with the tube and extending radially outwards thereof continuously about the periphery of the tube, spaced electrodes on the inner surface of the tube, and magnetic field producing elements between the flanges and received within the annular spaces subtended between the peripheries of the flanges and the outer surface of the tube between the flanges. (RX-172, at 1, lines 33-46).

80. In one form of the invention in the Sybron patent the tube has one flange at either end which provides streamlining for the tube, thereby adapting it to be inserted into a flow having a cross-section much greater than that of the tube. In another form the tube has a pair of flanges at either end, one pair of which provides for making a sort of spigot and ball connection with a pipe through which the flow is to be metered. (RX-172, at 1, lines 47-55).

81. Figure 1 of the British patent is said to show in side elevation one form of flow transducer for use in sampling a flow as of sewage in a large main. Figure 2 is an elevation of Figure 1 and Figure 3 is a part-sectional view and side elevation of the transducer of Figures 1 and 2. Figure 7 of the British patent is said to show a side elevation of the form of the invention shown in Figure 1, but modified for use in a pipeline. (RX-172, at 1, lines 60-78).

82. In the Figure 1 embodiment a sewage or other large main through which material flows has the Sybron transducer superseded therein from a rigid mast extending through a manhole or other access point. The transducer is generally in the form of a right circularly cylindrical tube having a right circularly cylindrical bore and streamlined ends. The flowing material completely fills the cross-section of the main. The streamlining of the transducer and its dimensions are such that the flow through the bore can be taken as a reasonable reliable measure of the flow through the main, without seriously affecting the flow due to the presence of the transducer and its supporting structure. The main structure of the transducer of Figure 1 of the British Sybron patent comprises a ceramic flow tube and a stainless steel cover. The flow tube has its end flared to define flanges integral with a

right-cylindrical part containing a cylindrical bore. The trailing edges of the flanges are, in effect, undercut by grooves to define ledges. The grooves and ledge are annular in form and extend all the way around the main cylindrical part of the tube. The tube has electrodes on the inner surface of the bore and leads extend out through the wall of the tube for connection to wiring. The grooves are said to receive the long edges of a rectangular stainless steel strip or cover the width of which is the distance between the grooves and the length of which is the circumference thereof. It is said that the cover or strip may be wrapped around the tube with its long edges sealed in the grooves so that its short edges meet and can be welded together. The junctures of the long edges and the grooves are said to be preferably sealed by any suitable means in order to keep the flowing material in the main from getting into the annular space between the flanges, the inside of the strip or cover and the main cylindrical part of the tube. (RX-172, at 1, lines 80-96, at 2, line 56).

83. In a second embodiment of the flowmeter of the British Sybron patent there is a bore, a ceramic tube a pair of flanges, a pair of annular grooves, and a strip of stainless steel (cover) is seated in the grooves. A second pair of flanges are provided, preferably being grooved, so that the elastomeric annular cushions can be cast on or stretched over the flanges for coupling in a pipe line. Those flanges are intended to fit into end bells or ring clamps at a break in a pipeline through which flow is to be measured. The strip or cover can have its short sides folded back in order that a channeled strip may slip over those short sides in order to clamp the strip or cover into cylindrical form. In this instance it is said that a fluid-tight seal between the strip or cover and the tube is not necessary since the

transducer is then not designed to be inserted bodily into a flow of larger cross-section than the transducer. This second form is illustrated at Figures 4, 5 and 6. (RX-172, at 2, lines 57-86).

84. In a unit of the British Sybron patent, saddle-shaped coils are provided for generating the magnetic field within the tube, the coils being fastened to the tube by means of a rectangular metal strap which may be in two like parts fastened together by fasteners of any suitable form. (RX-172, at 2, lines 87-93).

85. In an embodiment of the British Sybron patent, the saddle-shaped coils are provided for generating the magnetic field within the tube, the coils being fastened to the tube by means of a rectangular metal strap which may be in two like parts fastened together by fasteners of any suitable form. (RX-172, at 2, lines 87-94).

86. The tubes of the British Sybron embodiments are said to be readily fabricated out of porcelain, just as large ceramic electrical insulators are said to be made. It is said that customarily the porcelain tube surface is glazed at least in the bore of the tube. (RX-172, at 2, lines 122-126).

87. In the British Sybron patent preferably the electrodes are fired to the bore surface, being substantially flush therewith; that accordingly the tube surface on contact with flowing liquid will be substantially perfectly impervious, attack-resistant and uniformly smooth. It is said that as the tubes are mechanically quite strong, they readily adapt to being clamped in place and in fact flats of the tube are provided for that purpose as shown in the Figure 7 embodiment wherein a transducer is shown in a pipeline between flanges terminating adjacent the ends of the pipeline. Between the flanges and the flats of the Figure 7 embodiment elastomeric gaskets are provided

which seal the junctures between the transducer and the pipeline and also cushion the compressive forces of the flanges (typically metal) on the ceramic ends of the transducer. (RX-172, at 2, lines 127-130, at 3, lines 1-14).

88. In an embodiment of the British Sybron patent, bolts are said to pull the flanges together to provide the clamping force necessary to seal the transducer into the pipeline. Flats are said to enhance the seal in an arrangement of the kind shown in Figure 7 but even then are said to be not crucial and to serve no purpose in the Figure 1 embodiment. (RX-172, at 3, lines 15-21).

89. The claims of the British Sybron patent read:

1. An electromagnetic flow transducer comprising a substantially right circularly cylindrical ceramic tube the end regions of which are each provided with a flange, each flange being integral with the tube and extending radially outwards thereof continuously about the periphery of the tube, spaced electrodes on the inner surface of the tube, and magnetic field producing elements between the flanges and received within the annular space subtended between the peripheries of the flanges and the outer surface of the tube between the flanges.
2. An electromagnetic flow transducer as claimed in claim 1, wherein the flanges are formed by flaring of the ends of the ceramic tube.
3. An electromagnetic flow transducer as claimed in claim 1 or 2, wherein said annular space is covered by a cylindrical cover sealed on the peripheries of the flanges and extending from one flange to the other flange and all the way around said peripheries.
4. An electromagnetic flow transducer as claimed in claim 1, 2, or 3, wherein the inner surface of each end of the tube flares smoothly curvilinearly and radially outward through an angle of 90 with respect to said cylinder axis.



5. An electromagnetic flow transducer as claimed in any preceding claim, wherein said end regions are each also provided with a second flange extending radially outwards of the tube, each second flange being located adjacent a corresponding one of the first-mentioned pair of flanges and being of smaller diameter than said one of the first mentioned pair of flanges, the second pair of flanges having the first-mentioned pair of flanges between them.

6. An electromagnetic flow transducer as claimed in claim 5, wherein each of the second pair of flanges has an elastomer cover fitting flush to and entirely covering the surface thereof external to the inside of the tube.

7. An electromagnetic flow transducer as claimed in any preceding claim, wherein the tube has holes therein, said holes opening solely at the outer surface of the tube and being located between the flanges defined by the ends of the tube.

8. An electromagnetic flow transducer as claimed in claim 7, including a strap around the tube and holding the magnetic field producing elements in place, the strap having studs stated in said holes for fixing the position of the strap with respect to the tube.

9. An electromagnetic flow transducer as claimed in any preceding claim, wherein the ceramic tube is made of porcelain.

10. An electromagnetic flow transducer substantially as described with reference to Figs. 1 to 3, Figs. 4 to 6 or Fig. 7 of the accompanying drawings.

(RX-172).

German Patent 2,040,682

90. The German patent dated February 1972 is titled "Inductive Flowmeter with a Measuring Tube of Insulating Tube of Insulating Synthetic Resin, through which flows the Medium, Held in a Pipeline between Counterflanges of their adjacent Pipeline Parts." (RX-189).

91. The German patent discloses that the invention relates to an inductive flowmeter with a measuring tube of insulating synthetic resin through which flows the medium, held in a pipeline between counterflanges of its adjacent pipeline parts in which the measuring tube is totally embedded, magnetic-field-producing excitation coils and a ring-shaped laminated magnetic return path, and where two electrodes penetrating the measuring tube and the return path are arranged diametrical to one another and perpendicular to the magnetic field are held in contact with the medium. (RX-189 at Bates 500,908).

92. It is the object of the invention of the German patent to make possible inductive flowmeters without such supporting pipeline pieces with flanges on which an impairment of the magnetic field of the excitation coil and the appearance of eddy currents is prevented and then one has no need to put up with a constriction of the cross section in the measuring tube area. It is said that the invention succeeds in obtaining this object in that the measuring tube is clamped in at its two front faces between the counterflanges without being stressed by tension rods, and that the return path is designed as a bundle of magnetic sheets stacked in axial direction, which bundle is provided at the inside wall with concentric longitudinal slots for the concentric parts of the excitation coils, and that the end windings of the excitation coils lying radially outside of the inner boreholes of the bundle of laminations are surrounded at the circumference and front by magnetic shielding arrangements abutting at the front faces of the bundle of laminations, which shielding arrangements are cast into the measuring tube. The measuring tube with the bundle of laminations, the excitation coils with the shielding arrangements and the electrode is inserted as constructional

unit between the radially projecting counterflanges of the pipeline parts and is held closely pressed to the counterflanges by means of tension rods that penetrate the counterflanges (RX-189 at Bates 500,909).

93. In an exemplified embodiment, between counterflanges of two pipeline parts of ferromagnetic material is inserted a measuring tube of insulating synthetic resin against which are pressed by means of a tension rod of steel at the front the counterflanges. The measuring tube has a cylindric inside bore, out of which project the electrodes and into which is embedded a stacked tube-shaped bundle of laminations. The shafts of the electrodes penetrate the wall of the bundle of laminations and of the surrounding synthetic resin towards the outside. Into longitudinal slots of the bundle of laminations are embedded excitation coils with their concentric parts. Their end windings are brought in radial direction from the area of the internal borehole and embedded in the measuring tube which may display any optional external contour. To exclude any influence of the magnetic field through the counterflanges and the tension rods, the end windings are magnetically shielded against the outside. For reasons of space and shielding it is particularly favorable to let the pipe core and the unslotted ring core of identical radial dimensions, as the slotted sheet package, abut flush with the external circumferences. Thus it is said that there is extensively spatially defined also the magnetic return path at the end windings and insensitive against external influence. (RX-189 at Bates 500,910).

94. The claim of the German patent reads:

1. Inductive flowmeter with a measuring tube of insulating synthetic resin, through which flows the medium, held in a pipeline between

counterflanges of their adjacent pipeline parts, in which measuring tube are totally embedded magnetic field producing excitation coils and a ring-shaped laminated magnetic return path, and where two electrodes penetrating the measuring tube and the return path are arranged diametrical to one another and perpendicular to the magnetic field are held in contact with the medium, characterized in that, that the measuring tube (4) is clamped at its two front faces, unstressed by tensions rods (3), between the counterflanges (1a, 2a), and that the return path is designed as a bundle of laminations that is stated in axial direction out of magnetic sheets (5) which is provided at the inside wall with concentric longitudinal slots for the concentric parts of the excitation coils, and the end windings (6,7,8,9) of the excitation coils lying radially outside of the inside holes of the bundle of laminations (5) are surrounded at the circumference and front by magnetic shielding arrangements (11, 12) abutting at the front sides of the bundle of laminations (5), which are cast into the measuring tube (4).

2. Flowmeter according to claim 1, characterized in that, that each magnetic shielding arrangement (11, 12) consists of a wound tube core (11) abutting at the front at the bundle of laminations (5) and a laminated ring core (12) abutting at the respective tube core.

3. Flowmeter according to claim 2, characterized in that, that the tube core (11), the unslotted ring core (12) and the bundle of laminations (5) display identical outside dimensions.

(RX-189 at Bates 500,907).

95. The German patent does not disclose a flowmeter with a housing.

(RX-189).

96. The German patent is assigned to F&P. It was never commercialized because as one subjects the disclosed flowmeter to compressive forces, the flowmeter breaks. Thus the flowmeter will not take the normal actual loads.

(Reister Tr. at 272, 273).

97. The German patent discloses a magnetic flowmeter. It is flangeless but it has no spool and it has no external housing. In addition the device has a magnetic flux return path which is embedded in an epoxy material. (Reister Tr. at 270, 271).

98. The German patent was cited by the examiner in the prosecution of the application which led to the issuance of the '982 patent. (RX-171).

99. Both the flowmeters disclosed in the German patent and the British Sybron patent 1,424,875 have coils, are flangeless, have a structure laminated magnetic return path but they neither disclose a housing which performs a structural function nor a housing which is a magnetic return path. (Reister Tr. at 297).

100. The flowmeters disclosed in the German patent and the Sybron British patent 1,424,875 are wafer tube meters or flangeless meters. The German patent does not disclose a flowmeter with a metal housing and the flowmeter in the German patent was never commercialized. (Liptak Tr. at 1596).

Instrument Engineer's Handbook Vol. 1 (1969)

101. The handbook discloses a "short-form" magnetic flowmeter which is said to be "much shorter in length and, therefore, much lower in weight" than an earlier design. In the short form design the magnet coils are located inside the meter body and conform to the curvature of the meter body. The meter body is of magnetic material and performs the function of the iron core pieces required as a separate component in "earlier designs". The coils are potted and a lining is inserted to isolate the coil windings from the process fluid. It is said that placing the magnetic coils within the meter body

reduces the required size of the coils and results in less current consumption. Magnetic flowmeters are said to have many advantages including (1) measurement of "difficult" fluids such as very corrosive and abrasive slurries; (2) no obstruction to the fluid flow, (3) pressure drop equal to a straight section of pipe of equal length, (4) no special piping arrangement necessary, and (5) easily handled bi-directional flow. (RX-150 at 481, 482, 483, Fig. 5.8c).

102. Page 481 of the Handbook, edited by respondents' expert B. Liptak, discloses at Fig. 5.8c a magnetic flowmeter having flanges, and a non-magnetic tube having an insulating liner that defines the flow tube for carrying the flowing liquid. The flanges are bolted to the pipe flanges. (RX-150, at 481, Fig. 5.8c).

103. The same illustration (Fig. 5.8c) is shown in Mannherz U.S. patent no. 3,694,104, a patent cited by the examiner in the examination of the application that led to the '982 patent. (RX-171; RX-150 at 481 (Fig. 5c); CX-116 at Fig. ').

104. Respondents' expert Liptak testified that absent the Sybron patent, the German publication 2,040,682 and the Handbook reference would not show the flowmeter disclosed in the '982 patent. (Liptak Tr. at 1591).

#### VALIDITY & INFRINGEMENT

105. Michael Ebert is a patent lawyer and has been a member of the firm of Hopgood, Calimafde. et al. for about 20 years. He is principally responsible for the patent prosecution work for complainant Fischer & Porter. Ebert has prepared and prosecuted all of the patent applications of Fischer & Porter for the past 15 years. Foreign filings of Fischer & Porter are handled by the Hopgood firm through a foreign department at the Hopgood firm. The

attorney in the Hopgood firm who refers the matter to the foreign department handles the substantive matters involved in connection with the foreign prosecution. (Ebert CPX-12 at 4, 6, 7).

106. Ebert receives a foreign patent office action through an associate. The associate does not take the responsibility for preparing a response to a foreign patent office action without first consulting with Ebert. Ebert will consult his client if he needs the client's technical assistance for the interpretation of a cited reference in a foreign patent office action. (Ebert CPX-12 at 8, 9).

107. Ebert filed and prosecuted Fischer & Porter's U.S. patent applications serial numbers 536,275 filed September 27, 1983 ('212 patent), 398,809 filed July 16, 1982 ('82 patent), 174,609 filed August 1, 1980 ('963 patent), 075,037 filed September 12, 1979 ('340 patent), 811,276 filed June 29, 1977 ('018 patent) and 771,420 filed February 23, 1977 ('118 patent). (Ebert CPX-12 at 10, 11, 12; CX-103).

108. Concerning Australian patent application 58603/80, French patent application 800,287, Italian patent application 9351A/80, Australian patent application 19,778/83 and British patent application 8,002,221 Ebert received copies of the foreign patent office actions, commented on the references cited and made recommendations as to how the responses should be framed. He suggested arguments for distinguishing over the prior art. He further examined the prior art to determine its pertinence. He also received copies of the prior art cited by the foreign patent offices. (Ebert CPX-12 at 15, 16).

109. Ebert first became aware of the British Sybron patent 1,424,875 possibly in a British prosecution although it may have been cited in other foreign F&P applications. He became aware of it when it was cited in a F&P foreign application. (Ebert CPX at 17, 18 and 19).

110. Ebert stated that the British Sybron patent disclosed an electromagnetic flowmeter which was flangeless and to that extent it was pertinent to the British F&P Schmoock invention he was seeking to patent Great Britain because the Schmoock invention did deal with a flangeless electromagnetic flowmeter. In Ebert's opinion, the Sybron patent lacked essential features of the Schmoock invention, in that that the Sybron patent discloses a flangeless flowmeter structure that has a ceramic spool with large ceramic flanges at the end of the ceramic spool and these flanges were subjected to compression by the end flanges of the upstream and downstream pipes which was not the structure he was seeking to patent. (Ebert CPX-12 at 20, 21).

111. According to Ebert a flange is an enlarged annular body at the end of a pipe and it can serve as a mounting flange if it has holes in it. To be a flange it must extend radially away from the circumference of the body. Ebert was of the opinion that the Sybron patented device lacked a metal housing within which the components of the flowmeter was encased; that in the case of the Schmoock invention, the housing was provided the structural strength of the meter in that it was subjected to compression by the flanges of the upstream and downstream pipes. No such housing was said to be found in the Sybron patent. Ebert considered other important distinguishing features are that in the Schmoock invention, the cylindrical metal housing is ferromagnetic and serves as the magnetic return path for the electromagnets in the flowmeter and as a magnetic shield to isolate the internal electromagnets from exterior ferromagnetic bodies. (Ebert CPX-12 at 21, 22).



112. Ebert testified that there was no housing in the Sybron patent in the sense that he was using that term in the context of the Schmoock invention i.e. the housing providing structural strength for the magnetic flowmeters, and magnetic return path for the magnetic flux in the meter and acting as a magnetic shield. What was in the Sybron patent was said to be a shroud or a cover which merely acted to protect the meter against rain and to serve no other function. (Ebert CPX-12 at 23).

113. Ebert testified that in the Sybron patent coils are disposed in the region between the end ceramic flanges and are covered by the shroud (cover); that the shroud is interposed between the ceramic end flanges; and that there is a cavity defined between the shroud and the body of the ceramic spool with the coils are in the cavity. (Ebert CPX-12 at 23, 24).

114. Ebert regards the term "housing" as used by Schmoock in his patent application as a structural member which is necessary to the structural integrity of the device. He regards the shroud or cover in the British Sybron patent as not performing either a structural function nor a magnetic function. (Ebert CPX-12 at 24, 25).

115. According to Ebert, the shroud cover in the Sybron patent is of stainless steel which is by its very nature non-magnetic. In a response in the F&P British application it was argued that there was the relationship of the F&P claimed cylindrical housing to the end flanges of the upstream and downstream pipes and, because of that relationship, to the compressive force provided by the connecting bolts. This was said to be in the British Sybron patented device. Ebert does not think that the F&P arguments in the British F&P response related to the housing serving to carry the electromagnetic flux. (Ebert CPX-12 at 25, 26).

116. With respect to Ebert's definition of a flange it does make a difference whether the bolts go outside the meter or partially through the meter at some location. In the early patents according to Ebert the bolts in the flangeless meter went through bores on the body of the meter and in other cases the bolts encase the flangeless meter in that they are outside of the meter. If the bolts are inside a meter and they are ferromagnetic, they could well affect the operation of the meter in that they are then within the lines of flux within the meter. If ferromagnetic bolts are outside of the meter and encase the meter, they are isolated from the internal lines of flux by the ferromagnetic housing which acts as a shield. Hence the position of bolts according to Ebert does have an effect on the accuracy of a flowmeter as to when they are inside or outside the meter. (Ebert CPX-12 at 27, 28).

117. According to Ebert, U. S. patent nos. 4,181,018 and 4,098,118 show flangeless electromagnetic flowmeters and according to drawings of the patent the meters are interposable between the upstream and downstream end pipe flanges which have a predetermined diameter and circle of bolt holes. Some of the embodiments in the two patents have a cylindrical metal housing. Where there is a cylindrical metal housing, the housing has an external diameter which is smaller than that of the circle of bolt holes in the end flanges of the pipe, with which the meter is to be connected. (Ebert CPX-12 at 30, 31, 32).

118. With respect to the embodiment shown in figures 1, 1A and 2 of U. S. patent no. 4,181,018 the cylindrical metal housing does not have an external diameter smaller than that of the circle of bolt holes which are used to interconnect the meter with the pipe flanges. (Ebert CPX-12 at 33).

119. With respect to the embodiment shown in figures 1, 1A and 2 of U.S. patent no. 4,181,018 and figures 4, 4A and 4B of U. S. patent no. 4,098,118 the housing does not lie within the circle of bolt holes. (Ebert CPX-12 at 35).

120. A British patent issued on the F&P British patent application after the Sybron patent was cited by the British patent office. (Ebert CPX-12 at 35, 36, 37).

121. According to Ebert, the meter of the '982 patent is a much more compact meter than what was in the prior art. The primary significance is miniaturization. It is a much more compact meter. Thus the entire meter is confined within the area bounded by end flanges of the pipes whereas in the conventional flange meter the bulk of the meter extends beyond the pipe flanges. (Ebert CPX-12 at 39, 40).

122. Ebert testified that the miniaturization of the MINI-MAG is the practical consequences of taking the flanges off. Ebert did not think that he was qualified to answer why the miniaturization became possible with a flangeless meter because he is not a flowmeter designer. He knows from the flanged meter that he has seen that the flange meters are very massive whereas the flangeless MINI-MAG meter is highly compact and the entire body of the meter is within the circle of mounted bolts. (Ebert CPX-12 at 41, 42, 43).

123. Ebert did not prosecute German patent 2,040,682 cited during the prosecution of the '982 patent. The publication is assigned to Fischer & Porter. Ebert was not aware of the German patent until it was cited by an examiner. The publication shows a flangeless meter. (Ebert CPX-12 at 43, 44).

124. According to Ebert the British Sybron patent 1,424,875 shows a flangeless electromagnetic flowmeter at figures 1 through 7 and at figure 7 the flangeless electromagnetic flowmeter is interposable between the end flanges of upstream and downstream pipes of a line conducting a fluid whose flow rate is to be measured. Also the end flanges of the pipe in figure 7 have a predetermined diameter and a circle of bolt holes. (Ebert CPX-12 at 45, 46).

125. According to Ebert the Sybron patent does not describe a cylindrical metal housing for the flowmeter and Ebert is using the term "housing" in the context of what is disclosed and claimed by the '982 patent in issue. Ebert testified that in the Sybron patent the spool has massive end flanges which are well out of a shroud or cover so that the shroud does not serve to house the components of the flowmeter. Figure 7 of the Sybron patent, according to Ebert, comprises a stainless steel cover interposed between the flanges and serves no magnetic function and no structural function. It is merely a shroud. The shroud or cover does have an external diameter smaller than that of the circle of bolt holes in the end flanges of the pipes with which the meter is connected. Also when the meter is interconnected between the end flanges of the pipes, the cover or shroud lies within the circle of bolt holes in the flanges of the pipe. Moreover the flanges are bridged by bolts passing through the holes to encage the flowmeter and the purpose of that is to subject the meter to a compressive force which affects a fluid seal. (Ebert CPX-12 at 46, 47, 48).

126. Ebert testified that the British Sybron patent 1,424,875 does not show a non-magnetic spool coaxially disposed within the cover or shroud; that the spool is disposed in part inside the cover; that the massive end flanges of the spool is not disposed inside the cover. (Ebert CPX-12 at 48, 49).

127. Ebert testified that in the structure of the '982 patent, there is an important structural relationship in that with the spool coaxially disposed within the housing, the spool and the housing together are subject to the compressive force exerted by the bolts which bridge the end flanges of the upstream and downstream pipes. Even if the axial extent of the housing is greater than the axial extent of the spool, Ebert testified that the spool is still within the housing. (Ebert CPX-12 at 49, 50).

128. Ebert testified that in the '982 patent the ends of the spool by way of a gasket can be subjected to the compressive force. (Ebert CPX-12 at 51).

129. With respect to the phrase "said spool having a strength sufficient to withstand the pressure of fluid flowing in the conduit and said compressive force" in claim 1 of the '982 patent, Ebert testified that strength is obviously relative; that the claim does not specify what the fluid pressure or the compressive force is; that the spool is subjected to both forces; that there is the pressure of the fluid that flows in the conduit and there is the compression exerted by the mounting bolts and the spool must be capable of sustaining the pressure. He testified that the material from which the spool is made, its thickness and all of the other factors that come into the structural strength of a spool give the spool a capability; that the engineering designer can determine whether one has constructed a spool with particular characteristics through stress analysis. (Ebert CPX-12 at 52, 53).

130. Ebert testified that a special material is not described for the spool of the '982 patent; that he did not think that the British Sybron patent 1,424,875 discloses a spool having a strength sufficient to withstand the pressure of fluid flowing in the conduit and the compressive force exerted when the spool is interposed in the pipeline because in the structure of the '982 patent the compressive force is withstood by the combined action of a metal housing and the spool coaxially disposed within the housing with both being subjected to the compressive force created by the bolts which join the end flanges and the pipes; and that in the case of the Sybron patent, the compressive force is borne entirely by the ceramic spool and the position of the stainless steel metal shroud militates against the ability of the ceramic flanges to withstand compression. In any compression, in the Sybron British patent, the surrounded end flanges are squeezed between the edges of the cylindrical shroud and the metal flanges, although Ebert does not know that for a fact. (Ebert CPX-12 at 55, 56).

131. Ebert has never seen a flowmeter of the type described in the British Sybron patent 1,424,875. He has never heard of a Sybron meter of the type disclosed in the British patent. He has no knowledge that a meter of such type was ever on the market. He has had no indication as to whether the meters disclosed in the Sybron patent actually existed. (Ebert CPX-12 at 56, 57).

132. Ebert understands the term "within" in claim 1 of the '982 patent to mean that in order for the spool to be within the housing, the spool must be both radially and coaxially within the housing. (Ebert CPX-12 at 59).

133. Ebert testified that he did not consciously leave out the British Sybron patent 1,424,875 when he cited prior art to the U.S. patent examiner on

March 1, 1983 because he was not aware of the British patent at that time; and that he did not become aware of the British Sybron patent until March 10, 1983. Ebert never considered amending his disclosure of prior art to the U.S. examiner to include the British Sybron patent. Ebert did not regard the Sybron patent in connection with the British prosecution of the F&P patent as touching on the essential features of the invention of the '982 patent; and he saw no reason in the U.S. prosecution to call the British patent to the examiner's attention and considered the British patent no better than the German patent Ebert brought to the U.S. examiner's attention. (Ebert CPX-12 at 62, 63).

134. According to Ebert there is no cylindrical housing or flanged spool in German patent 2,040,682. While the Sybron patent has a flanged spool and calls for a cover, most of the spool is outside of the cover i.e. the end flanges which are an important part of the spool are well outside the cover. (Ebert CPX-12 at 64, 65).

135. Ebert testified that the drawings of the '982 patent discloses that the spool is both radially and coaxially inside the housing. Reference was made to figures 2 and 3. Also Ebert refers to col. 5, lines 23-26 of the '982 patent which states that "The opposite ends of the split housing are provided with annular closing plates ... whose inner peripheries mate with the outer peripheries of end flanges ... of the spool to define an enclosed inner chamber in the space between the spool and the housing." (Ebert CPX 12 at 66, 67).

136. The fact that the meter in the '982 patent is flangeless does not affect in any way its ability to withstand fluid pressure according to Ebert. (Ebert CPX-12 at 69).

137. Ernesto E. Blanco, a witness proffered by complainant, was qualified as an expert in the field of mechanical engineering design, including structural and force relationship in electromagnetic devices. (Tr. at 557-579, 1102; CX-5).

138. Prof. Blanco obtained a degree of bachelor in mechanical engineering from Rensselaer Polytechnic Institute in 1956. (Blanco Tr. at 558).

139. The flow meter structural arrangement in the '982 patent in issue is a cylindrical housing made out of ferromagnetic material and coaxially with the housing is an insulated spool made out of non-magnetic material which contains also electric coils on top and below. The spool further contains two electrodes that measure the voltage when the flow occurs. The housing and the spool are a unit according to the patent, i.e. the two of them work together in sharing the loads of the system and at the same time provide for the proper function of the system. (Blanco Tr. at 580, 581).

140. In a flowmeter of the type disclosed in the '982 patent, the load is applied coaxially by action of the two pipe flanges that are at each end of the unit, and the two flanges are bridged by a set of bolts, four, six or eight which go outside of the cylindrical housing. (Blanco Tr. at 581).

141. CPX-21 (an F&P Type 10 D 1475 3 inch MINI-MAG Flowmeter which has a birdcage arrangement through 4-bolts (CPX-36)) shows two pipe flanges on each side of the flowmeter. The force is applied by using the four bolts, tightening the bolts until the two flanges grip the unit in between and sufficient fluid seal is provided. (Blanco Tr. at 581, 582).

142. CPX-23 is a Krohne 3" DELTAFLUX Flowmeter and CPX-24 is a Krohne 1/4" ALTOFLUX Flowmeter.



143. F&P CPX-21 is interposable between the end flanges of the upstream and downstream pipes of a line conducting a fluid whose flow rate is to be metered and that would apply to Krohne's CPX-23 and CPX-24. (Blanco Tr. at 585).

144. Regarding CPX-29 which is a disassembled F&P MINI-MAG flowmeter and CPX-23, CPX-24 and CPX-21 the end flanges of the pipes on the line have a predetermined diameter and a circle of bolt holes. (Blanco Tr. at 585, 586).

145. F&P CPX-21 comprises a cylindrical metal housing as does Krohne CPX-23 and Krohne CPX-24. (Blanco Tr. at 586).

146. The F&P CPX-21 cylindrical housing has an external diameter which is smaller than that of the circle of the bolt holes as does Krohne CPX-23. (Blanco Tr. at 587).

147. The end portions of the F&P CPX-21 is bridged by bolts passing through the holes in the pipe flanges to engage the F&P unit and subject the unit to a compressive force effecting the fluid seal. The same is found in Krohne's CPX-23 and Krohne's CPX-24. (Blanco Tr. at 588, 590).

148. The force relationship in F&P's CPX-29 is that resisted by the spool and the housing. There is a joint between the spool and housing which transfers the load from the face of the spool to the housing. The top of the housing in F&P's CPX-29 is joined to the spool by something that looks like a shoulder. It is a notch. The notch is on the edge of the spool and it engages a corresponding face on the top of the housing so that the forces applied are resisted by the housing simultaneously. In the F&P CPX-29 the housing and the spool are joined by welding. (Blanco Tr. at 588, 589).

149. In Krohne's CPX-23 the spool and the housing are joined by shrink fitting which is an operation that requires the heating of the outside

housing, slipping the heated housing over the coils and allowing it to cool and shrink over the surface to get a good joint. (Blanco Tr. at 590, 591).

150. In Krohne's CPX-23, the forces are shared between the spool and the housing. (Blanco Tr. at 591).

151. The sharing of forces between the spool and the housing in Krohne's CPX-23 was shown by tests conducted under Prof. Blanco's direction. In these tests the housing was supported and the spool was pushed out to determine the force necessary to remove the spool. The question was whether in applying the sealing force against only the spool would any loading be applied to the housing. The answer was yes because even with a small air gap between the spool and housing as soon as force is applied to the spool the spool expands a little bit and begins to grip the housing. In a test performed under Prof. Blanco's direction the Krohne CPX-23 was compressed between two flanges with gaskets that are only touching the ceramic spool. A load from a pipe is applied to the spool and the load is resisted by the spool. In such a case, as soon as a load is applied to the spool, the spool tends to expand sideways and its diameter increase and as the diameter increases the spool begins to touch the housing and the housing begins to take part of the load. If the housing and spool is touching at the beginning, the housing immediately carries part of the load. The presence of an air gap between the housing and spool is very unrealistic because then the spool would fall off from the housing. The point is when the spool is compressed a part of the load is eventually transferred to the housing. (Blanco, Tr. at 591, 626-630; CPX-35).

152. A human hair measures approximately 3,000 micro-inches which is 3 thousandths of an inch and the expansion distance (the distance between the face of the spool that is being pushed and the initial position of the spool)

in the test performed under Prof. Blanco's direction is 200 micro-inches which is less than one-tenth of the hair. In the test there is a computer display of the mathematical phenomenon that occurs when one loads the spool and housing together. Thus it is like a computer model of a real situation. There is no actual forces applied. There are only values in the equation and then they are transferred into the display almost as it is was a real experiment. It is called computer-aided design i.e. one designs and test things in the computer without building them. Prof. Blanco has done this test with other devices e.g. in the design of a medical instrument, but not with electromagnetic devices. The test is accepted in the industry. The test is as reliable as the mathematics used in order to carry out the experiment. The test is accepted in engineering. There are cars designed with this test. In the test some assumptions are made as is done in any engineering testing. (Blanco Tr. at 629-634).

153. The purpose of the test which produced a video film (CPX-35) was to show that even though there may not be any visible means of locking the housing against the spool or vice versa, the mere fact that they are joined by merely touching, is enough for the load to begin to be transmitted and shared by the housing. With Krohne CPX-23 the spool (white element) is being held inside of the housing. supposedly by the use of a shrink-fit. Whatever force is put on the spool is going to be transmitted to the housing and vice versa and the whole assembly will work as a unit. The spool and housing are working together. (Blanco Tr. at 636, 637; CPX-35).

154. In Krohne CPX-24, the end flanges of the pipe unit is bridged by bolts passing through the holes to engage the unit and subject the unit to a compressive force effecting a fluid seal. (Blanco Tr. at 638, 639).

155. The F&P meter CPX-29 further comprises a non-magnetic spool coaxially disposed within the F&P housing. The spool is joined to the housing on the periphery. The housing holds the spool. Krohne CPX-23 comprises a non-magnetic spool coaxially disposed within the Krohne housing. The term "coaxially" means that the two center lines coincide i.e. it is exactly in the center of a housing and supported by the housing. (Blanco Tr. at 640).

156. The smaller Krohne CPX-24 comprises a non-magnetic spool coaxially disposed within the housing. To show this, Prof. Blanco removed the solenoid from the top which solenoid was not within the circular portion of the housing of CPX-24. (Blanco Tr. at 640, 641; CPX-24).

157. The F&P CPX-29 has a spool with end flanges which are seated against the ends of the upstream and downstream pipes. A gasket seats against the end flange of the spool and the spool is pressed by means of the flange. (Blanco Tr. 642, 643).

158. In the F&P CPX-29 a cavity is defined by the joint between the top of the housing and the spool. The Krohne CPX-23 defines with the Krohne housing an internal cavity which is between the spool and the housing. There is also a cavity in the Krohne CPX-24 between the white spool and the housing. (Blanco Tr. 644).

159. The F&P CPX-29 spool forms a fluid conduit having a longitudinal flow axle which joins the upstream and the downstream pipes and the conduit is between the two flanges. The two flanges receive the pressure from the end flanges of the upstream and downstream pipes. (Blanco Tr. at 644, 645).

160. The Krohne CPX-23 forms a fluid conduit having a longitudinal flow axis which joins the upstream and downstream pipes. The longitudinal flow axis is the hole along the center of the spool. The axis of the cylinder

defined by the spool is exactly the same as the longitudinal flow axis because they are coaxial. The Krohne CPX-24 has a fluid conduit. Krohne CPX-23 is interposed between pipe ends to form a conduit. (Blanco Tr. at 646, 647).

161. In the design of the F&P CPX-23, CPX-23 had a strength sufficient to withstand the pressure of fluid flowing in the conduit and the compressive force. The Krohne CPX-23, according to its design, has a strength sufficient to withstand the pressure of fluid flowing in the conduit and the compressive force. The smaller Krohne CPX-24 should have a strength sufficient to withstand the pressure of fluid flowing in the conduit and the compressive force. (Blanco Tr. at 647, 648).

162. The F&P CPX-29 has a pair of electromagnetic coils disposed at diametrically opposed sides of the spool to create a magnetic field whose lines of flux extend across the conduit of the F&P spool. The magnetic field flows between the two coils and returns through the outside. It is a closed magnetic field through the housing. Krohne CPX-23 has a pair of electromagnetic coils dispersed at diametrically opposed sides of the Krohne spool to create a magnetic field whose lines of flux extend across the conduit of the Krohne spool. The coils in CPX-29 and CPX-23 are called saddle-shaped coils. (Blanco Tr. at 649, 650, 651).

163. In the smaller Krohne CPX-24 there is a pair of electromagnetic coils disposed at diametrically opposed sides of the spool to create a magnetic field whose lines of flux extend across the conduit of the spool. The coils in the smaller Krohne CPX-24 are a solenoid type coil. A solenoid coil is presumably used because the size of the meter is too small to obtain the flux needed with a saddle type coil so the solenoid type coil is more convenient for the size of the meter. The solenoid coil provides more flux than a saddle coil. (Blanco Tr. at 652).

164. In the F&P CPX-29 the F&P coils lie on a coil axis which is normal to the flow axis of the spool. The center line of one coil passes through the center line of the opposite coil perpendicular to the axis of flow of the flowmeter. In the larger Krohne CPX-23 the coils essentially lie in the same relationship as in the F&P CPX-29. In CPX-23 there is a holding non-magnetic strap that holds the things together. (Blanco Tr. at 653, 654).

165. The smaller Krohne CPX-24 has coils which lie on a coil axis which is normal to the flow axis of the Krohne spool. (Blanco Tr. at 654, 655).

166. The F&P CPX-29 has a pair of electrodes mounted on a spool at diametrically opposed positions along an electrode axis perpendicular to both the coil axis and to the flow of the axis whereby the fluid which flows through the conduit intersects the lines of flux to induce a signal in the electrodes which is a function of flow rate. (Blanco Tr. at 655, 656).

167. The electrodes in the F&P CPX-29 are at diametrically opposed positions along an electrode axis perpendicular to both the coil axis and to the flow axis. The pair of electrodes are mounted on the spool. The coil axis is a line passing through the center of the core and the axis is perpendicular to the electrodes' axis. The fluid which flows through the conduit of F&P CPX-29 intersects the lines of flux to induce a signal in the electrodes which signal is a function of flow rate. (Blanco Tr. at 656, 657, 658, 659).

168. In the large Krohne CPX-23, there is a pair of electrodes mounted on a spool with the electrodes at diametrically opposed positions which is along an electrode axis perpendicular both to the coil axis and to the flow axis. The flow in Krohne CPX-23 which passes through the conduit intersecting the lines of flux induces a signal in the electrodes. The signal is a function of flow rate. (Blanco Tr. at 659, 660).

169. The smaller Krohne CPX-24 has a pair of electrodes mounted on a spool and the electrodes are at a diametrically opposed position which position is along an electrode axis perpendicular both to the coil axis and to the flow axis. Also the fluid flow through the conduit intersecting the lines of flux induces a signal in the electrodes which is a function of flow rate. (Blanco Tr. at 661, 662, 663).

170. Referring to claim 2 of the '982 patent, the F&P 3 inch CPX-29 and the Krohne CPX-23 have coils disposed in the cavity defined by the housing and spool. (Blanco Tr. at 663, 664).

171. Referring to the smaller Krohne CPX-24 the coils are not disposed in a cavity defined by the housing and the spool. The coils do extend into the cavity defined by the housing and the spool. (Blanco Tr. at 665, 666).

172. Referring to the Krohne 3 inch CPX-23 the coils are of a saddle shape. Also in F&P CPX-21 the coils are saddle shaped. (Blanco Tr. at 665).

173. In the F&P 3 inch CPX-29, the shape of the coils is conformed to the curvature of the housing. In the Krohne CPX-23 the coils also conform to the curvature of the housing. (Blanco Tr. at 666, 667).

174. The F&P CPX-29 has a cylindrical housing formed of ferromagnetic material which joins the electromagnetic coils to define a magnetic circuit. A magnet is able to be attached to the housing surface and hence the housing is ferromagnetic. The cylindrical housing of the Krohne CPX-23 is ferromagnetic. A magnet will attach to the Krohne housing. The ferromagnetic material of CPX-23 joins the electromagnetic coils to define a magnetic circuit. (Blanco Tr. at 667, 668, 669).

175. In the small Krohne CPX-24, the housing is formed of ferromagnetic material. A magnet will attach to the housing. The ferromagnetic material of

the housing of CPX-24 joins with the electromagnetic coils of CPX-24 to define a magnetic circuit therewith. (Blanco Tr. at 669).

176. According to Prof. Blanco, Sybron British patent 1,424,875 describes a ceramic or porcelain spool with flanges and an electromagnetic circuit provided by two coils mounted against the ceramic spool with electrodes to pick up the signal from the passing fluid. A strap holds the coils together against the flow tube. The patent also describes a stainless steel sheet metal cover that is wrapped around the space of the coils. (Blanco Tr. at 671, 672).

177. Prof. Blanco is of the opinion that the British Sybron patent does not suggest to a typical, ordinary engineer of the 1970's to use a magnetic metal housing which has no flanges on it in an electromagnetic flow meter. Rather the Sybron patent leads an observer in the direction of believing that there is no need for a return magnetic path because the patent does not show anything that indicates that the designer considered that necessary. Most stainless steels are not magnetic. The austenetics are not magnetic and they are the most common ones that are used for decorative or for other sheet metal operations. A sheet metal stainless steel would not be able to support a magnetic circuit, and hence the Sybron patent teaches in the direction of not needing a magnetic housing. The Sybron patent discloses only a stainless steel cover. It does not provide for a return magnetic field through the housing. There is no housing. (Blanco Tr. at 674, 675).

178. According to Prof. Blanco the Sybron patent shows no indication that a return magnetic housing is needed in order for the meter to work. The cover in the Sybron patent is not attached in any way and a cover is not suppose to transfer loads or to take any loads. The function of a cover is to



protect something inside, not to form the part of the structure. The cover is not a structural element. The cover of the Sybron patent device is not intended to be part of a magnetic circuit. It is not intended to shield the magnetic field of the meter against extraneous interfering magnetic fields because the cover is not a magnetic material. Also covers are not intended to be a structural material or structural element. (Blanco Tr. at 675, 676).

179. Electromagnetic flow transducer is the same as an electromagnetic flowmeter. (Blanco Tr. at 689).

180. Prof. Blanco is of the opinion that a cover is not a structure. A cover is an envelope. The cover shields the instrument in the Sybron patent against mechanical or perhaps dust or some other accidental intrusion. A housing is a structural member. A cover is not a functional part. In general one can take a cover off and the device will work in the same way. A housing cannot be taken off because it is part of the device. A housing has functional properties related to the device. A housing has to support members against impact, stress forces, and at the same time it usually performs a cover function. (Blanco at 683, 684, 685).

181. According to Prof. Blanco, in Krohne's 3 inch CPX-23 there is a housing which maintains the center of the spool in the proper position in relation to every other member and at the same time it distributes the loads applied by the flanges. The housing takes part of the load that would not be normally applied to the spool if the housing was not there. The housing does protect the spool. It positions the spool and at the same time it forms another function which is the return of the magnetic path. It closes the magnetic circuit because the housing is magnetic. (Blanco Tr. at 685).

182. According to Prof. Blanco, the cover in the Sybron patent is very thin because sheet steel is referred to (rectangular stainless steel strip) and sheet steel is usually a thin material. In Sybron the cover is attached to the spool instead of being the other way around. Thus the cover is supported by the spool. A housing supports the device it is used with. The cover is usually positioned by the spool. The spool in the Sybron patent has notches and the stainless steel strip is wrapped around the spool so the spool holds the cover. In Figures 4 and 5 the spool supports the cover. In contrast in F&P CPX-29, the housing supports the spool and the spool is positioned and reinforced, by the housing. (Blanco Tr. at 686, 687).

183. Referring to Figure 6 of the Sybron patent the cover is formed around the spool. (Blanco at Tr. 687, 688).

184. According to Prof. Blanco, Instrument Engineer's Handbook at page 481 describes an electromagnetic flowmeter of the flanged type with two saddle-shaped coils and common electrodes at 90 degrees to the magnetic axis. The flanges are on the housing. The flanges extend outwardly from the housing. The flanges mate on the inside of the pipe flanges. There is no spool shown at page 481 and because it is a flanged meter there are no compressive forces in the center of the unit because the two flanges are attached to the inside of the pipe flanges. The only stress in between might be bending stresses but not compressive forces. Any compressive forces in the Handbook flowmeter are between the flanges of the pipe and the flanges of the flowmeter. There is nothing at page 481 which would suggest to an ordinary engineer in the 1970s to put a spool in the housing as part of a combined unit. (Blanco Tr. at 691, 692; RX-188).

185. In German patent 2,040,682 to Kettleison, according to Prof. Blanco, there is described an electromagnetic flangeless flow meter containing two coils with laminations in between the coils and extending all around the unit. The laminations are ferromagnetic laminations. The lamination completes the magnetic circuit. Some laminations encircle the coils inside and the whole system of laminations and coils is embedded into a plastic resin. The laminations are a magnetic flow path circuit. There is no housing suggested in the German patent. There is no suggestion to combine a spool and a housing made in either the drawings or the specification of the German patent. The arrangement in the German patent is intended to be inserted between the pipe ends of the pipeline. (Blanco Tr. at 694, 695, 696; RX-188).

186. Prof. Blanco is of the opinion that the Sybron British patent, the German publication and the Handbook reference taken either individually or in combination would not make it obvious to the ordinary engineer in the 1970s to combine a magnetic metal housing coaxially with a spool to form an electromagnetic flowmeter unit wherein the spool and the housing share the compressive force causing a fluid seal between the unit and the ends of the pipes. Prof. Blanco sees nothing in the references that indicates to someone skilled in the art to combine the spool and the housing so that they share the load and they function with an electromagnetic path on the outside. (Blanco Tr. at 697, 698, 699; RX-188, RX-189, RX-172).

187. Figure 1 in the British Sybron patent 1,424,875 is a standup pipe that holds the meter. The pipe is lowered through the manhole into the sewer. (Blanco Tr. at 700).

188. Figure 7 of the British Sybron patent shows a flangeless electromagnetic flowmeter interposed in a pipeline through which fluid flows. The flangeless electromagnetic flowmeter is engaged within bolts that extend outside the meter. The non-magnetic spool or flow tube of Figure 3 is used in the Figure 7 embodiment. End flanges of the pipe have a predetermined diameter and a circle of bolt holes. In Figure 7 there is a cylindrical metal cover. The cylindrical metal cover has an external diameter which is smaller than that of the circle of bolt holes and the cover lies within the circle of bolt holes. The pipe flanges are bridged by bolts passing through the holes to engage the unit. This subjects the meter to a compressive force effecting a fluid seal. The spool in Figure 7 is provided with flanges which are seated against the ends of the upstream and downstream pipes. The spool defines with the cover an internal cavity and the spool forms a fluid conduit having a longitudinal flow axis which joins the upstream and downstream pipes. (Blanco Tr. at 702, 706, 708, 713, 714, 715, 721, 722).

189. The spool of Figure 7 of the Sybron patent has a strength sufficient to withstand the pressure of fluid flowing in the conduit. Prof. Blanco has some doubt whether the spool would have a strength sufficient to withstand compressive force because ceramic is very, very brittle. It would take a "very much" skilled engineer to design a ceramic spool to take compressive force. One would have to make the spool rather bulky to make it strong enough and a bulky design would not be a good design. (Blanco Tr. at 723, 724, 725).

190. According to Prof. Blanco it is claimed in the British Sybron patent that the ceramic spool is capable of withstanding compressive forces. As the spool is shown in the British patent it does not seem to be so designed to withstand compressive forces that one may find in a application as stated

for Figure 7. The spool can be redesigned or reformed and then the spool may be able to withstand the compressive force. The inside of the spool is not shown in Figure 7 and in Figure 3 the spool appears rather weak for pipeline application because there are bending stresses and hence it is a ceramic tube subjected to bending stresses not just compressive stresses and also impact. (Blanco Tr. at 725, 726, 727).

191. By the time a mechanical engineer graduates the engineer has taken courses which shows the engineer how to calculate forces imposed on various bodies. There is nothing in the design of the meter in the Sybron patent which would suggest that one of ordinary skill in the art could not readily calculate the forces imposed on the spool. Prof. Blanco thinks that the spool in the British patent can be designed to withstand stresses but he does not consider it a good practice. He does not consider it a good practice to have a fragile or brittle element as ceramic in the Sybron patent subjected to the stresses that one finds in a pipeline installation. (Blanco Tr. at 728, 730).

192. Porcelain is a rather brittle material. It is very good in compression but not good in tension and if one subjects porcelain to the kind of stresses that one may find in a pipe application the spool may have to be very massive. According to Prof. Blanco, for pipeline application one would have to change the dimensions of the spool in Figure 7, and increase the size of the spool. The spool would have to have an awful lot of thickness in the walls than appears in the Figure 7 embodiment. A spool for pipeline application could be produced. A spool could be designed to take a lot of compressive force but it would be massive. An engineer could also calculate bending moments and size the spool to accommodate such moments. (Blanco Tr. at 729, 730, 731, 732, 733).

193. The electromagnetic flowmeter of Figure 7 of the British Sybron patent has a pair of electromagnetic coils that are disposed at diametrically opposite sides of the spool and they function to create a magnetic field whose lines of flux extend across the conduit. The coils lie on a coil axis which is normal to the flow axis. The flangeless electromagnetic flow meter of Figure 7 of the Sybron patent has a pair of electrodes mounted on the spool and they are mounted at diametrically opposed positions along an electrode axis that is perpendicular both to the coil axis and to the flow axis. The operation of the electrodes is such that when the fluid that flows through the conduit it intersects the lines of flux and a signal is induced in the electrodes which is a function of flow rate. (Blanco Tr. at 733, 734, 735).

194. In Figures 3 and 7 of the British Sybron patent a cavity is formed between the cover and the flow tube or spool. Electromagnetic coils are disposed in that cavity. (Blanco Tr. at 733, 734, 735).

195. The cover in the British Sybron patent is located within notches and the cover is not necessarily fitted such that the end faces of the cover butt against the inner end faces of the spool. The Sybron patent does not state one way or the other whether or not the end faces of the cover butt against the inner end faces of the spool. The cover in the Sybron patent is not press fitted whereby the load would be carried by the cover. If the end faces of the cover in Sybron abuts against the inner end faces of the spool, the cover could take some of the compressive force. (Blanco Tr. 746, 747, 749, 751).

196. When Prof. Blanco was asked to state where in the '982 patent there is any discussion concerning the sharing of forces between the spool and

housing and the extent to which those forces are shared, Prof. Blanco made reference to that portion of claim 1 which reads:

A. a cylindrical metal housing having an external diameter which is smaller than that of the circle whereby when the unit is interposed between the end flanges of the pipes, the housing lies within the circle and the flanges are bridged by bolts passing through the holes to engage the unit and subject it to a compressive force effecting a fluid seal;

He explained that there is reference in that portion to "unit," not just the housing; that the housing lies within the circle of bolts and the pipe flanges are bridged by bolts passing through the holes to engage the unit, which includes the housing and spool, and to subject the unit to a compressive force effecting a fluid seal. Prof. Blanco also made reference to the introductory portion of claim 1 which reads: "A flangeless electromagnetic flowmeter unit interposable between the end flanges of the upstream and downstream pipes. . . ." Prof. Blanco testified that the compressive force is applied simultaneously to the housing and the spool as a unit but in varying degrees to each and that the compressive force is applied to both at all times. Prof. Blanco also testified that the phrase "said compressive force" in clause B of claim 1 refers to the compressive force stated in clause A of claim 1. No compressive force is said to be defined in clause B of claim 1. Compressive force in claim 1 is said to pertain to both the housing and the spool. (Blanco Tr. at 758, 759, 760, 761).

197. The "unit" in claim 1 takes the compressive force. The only parts that an engineer would take into account as being compressed are the parts that are designed to be compressed and the coils are not designed to be compressed. It is only the cylindrical metal housing and the non-metallic spool which are subject to compressive forces. (Blanco Tr. at 762, 763).

198. When asked whether there is any place else in the '982 patent which supports the assertion that the housing and the spool are to share the compressive load, Prof. Blanco made reference to the following:

The housing in this related case is formed by complementary half-pieces which include end plates that join the corresponding ends of the spool to define the inner chamber. (Col. 2, lines 41-44).

. . . .

Surrounding the spool and concentric therewith is a cylindrical housing fabricated of ferromagnetic material and formed of complementary half pieces which include arcuate end plates that join the corresponding end flanges of the spool to define an enclosed inner chamber. (Col. 3, lines 54-59).

. . . .

The opposing ends of the split housing are provided with annular closure plates 22 and 23 whose inner peripheries mate with the outer peripheries of end flanges 10A and 10B of the spool to define an enclosed inner chamber in the space between the spool and the housing. (Col. 5, lines 23-28).

The word "join" according to Prof. Blanco means that the joined parts are transferring loads in between. The term "mate" means "join" and thus the parts could be welded, press fitted or mounted in some way that the forces that are transmitted into the unit are shared, deliberately by design, between the spool and the housing. Although nothing is literally said in the above passages about transfer of forces between the spool and the housing, Prof. Blanco considers the transfer of forces inevitable in the use of the word "join." He further testified that "Not only that the joining is a source of the transfer of load between the two members but also the item that you see here in claim 1, A and B [of the '982 patent], which when you combine that



with the structure of the patent, what else can it be." (RX-171 at 764, 765, 766, 767, 768, 769).

199. The transfer of load between the spool and the housing is one of the characteristics of the invention of the '982 patent. It is an important feature. (Blanco Tr. at 769).

200. F&P CPX 29 is a disassembled part. In the assembled F&P flowmeter (CPX-21) the parts are welded so there is no question of continuity. There is an intentional touching. The spool and the housing are designed to touch. (Blanco Tr. at 773, 775, 776).

201. In claim 3 of the Sybron British patent, the cover is sitting on the periphery of the flanges. The cover in Sybron prevents anyone from tampering with the coil and keeps out any hostile environment. A cover can internally seal the internal constituents of a flow meter. (Blanco Tr. at 778, 779).

202. The term "housing" in McGraw-Hill Dictionary of Scientific and Technical Terms is defined a "A case or enclosure to cover and protect a structure or a mechanical device." (Blanco Tr. at 1198; RRX-20).

203. A Webster's Seventh New Collegiate Dictionary (1965) defines "housing" in part as "2 a: something that covers or protects b: a casing (as an enclosed bearing) in which a shaft revolves c: a frame or other support for mechanical parts."

204. The Dictionary of Science and Technology (1974) defines "housing" as applied to electrical engineer, etc. as "housing: containment of apparatus to prevent damage in handling or operation." Prof. Blanco calls that definition a cover or a guard or a protector but not a housing. (Blanco Tr. 1209, 1210; RRX-21).

205. An F&P catalogue states in part: "The remote mounted signal converter is housed in a weatherproof, die cast aluminum box designed for surface (panel) or pipe mounting options." Prof. Blanco would call it a cover. Its' base may have some load bearing capabilities. He doesn't say that it should have such capabilities. The function of the box is protection. (CX-12 at 13; Blanco Tr. at 1213, 1214).

206. Claim 1 of the '982 patent, clause B states in part: "said spool having a strength sufficient to withstand the pressure of fluid flowing in the conduit and said compressive force." Prof. Blanco testified that this requirement means that the spool must have a strength sufficient to withstand the pressure of the fluid flowing in the conduit which would tend to expand the spool and tend to make it larger and that such would put tensile stresses on the spool. The "compressive force" in the recitation however, according to Prof. Blanco, must come from the outside, i.e. from flanges that are compressing the spool along with the housing so as to affect the fluid seal to prevent leakage. It also appears from the "whole configuration" that the spool is taking most of the compressive force because the spool is in line with the pipe. In clause A of claim 1 of the '982 patent the housing is subjected to the compressive force. The spool of the claim 1 flowmeter must be designed to take the compressive force to affect the fluid seal at the ends so that it would not leak, and at the same time have sufficient strength so that it would not burst under the pressure from the fluid inside. (RX-171; Blanco Tr. at 1224, 1225, 1226, 1227, 1228).

207. According to Prof. Blanco, one way of reducing the size of the flowmeter of the '982 patent is to have all of the members in the compression line receive and share the load and thus he interprets the teaching of the

'982 patent as having both spool and housing take the compressive force. In this way the design is efficient. (Blanco Tr. at 1228).

208. Col. 4, lines 50-56 of the '982 patent states:

Surrounding the lined metal spool 10 and concentric therewith is a split cylindrical housing or casing formed by complementary half pieces . . . , the longitudinal edges of these pieces being seam welded or otherwise joined together to complete the housing.

That portion of the patent, according to Prof. Blanco teaches nothing about whether the housing is sharing any compressive forces but it does teach to Prof. Blanco that the word "joined" is used in exactly the same way as the word "join" is used at col. 3, line 57.

viz. Surrounding the spool and concentric therewith is a cylindrical housing . . . formed of complimentary half pieces which include accurate end plates that join the corresponding end flanges of the spool and define an enclosed inner chamber.

(Blanco Tr. at 1234, 1235, 1236, RX-171).

209. According to Prof. Blanco, when two parts are joined together and they are subjected to a compressive force, the compressive force is transmitted to both parts. (Blanco Tr. at 1237).

210. According to Prof. Blanco, "join" means units are touching. (Blanco Tr. at 1238).

211. According to Prof. Blanco there may be a gasket between the pipe flanges and the faces of the flow meter and at that point one may have a condition where the spool flanges are approximately substantially the same length as the housing and when the two are compressed, there is a sharing of the loads between the two. The forces are applied both to the housing and to the spool simultaneously. That is not necessarily predicated on the assumption that the length of the spool is equal to the length of the housing. There is some deflection in the gasket and there is also some

deflection in whatever member takes the load first, assuming they are not welded which they are in the F&P flowmeter. If the spool and the housing are not joined by continuity and only touching and they are of the same lengths and the gaskets are compressed against the meter, the load is distributed to the housing and to the spool. (Blanco Tr. 1241, 1242).

212. The spool and the housing touch the pipe flanges through the gasket at the same time in the flowmeter of the '982 patent. The gasket is the primary load transmitting element between the pipe flanges. In the F&P flowmeter (CPX-21) the flanges of the spool are welded to the housing so there is no question about the fact that the load would be immediately transmitted and it does not depend on the deflection of the gasket. (Blanco Tr. at 1242, 1243).

213. There is no mention of the gasket in the '982 patent. The use of a gasket is a standard method of sealing pressure vessels. (Blanco at Tr. 1244, 1245).

214. If the spool were in fact coaxially shorter than the housing, it would depend on how short the spool is as to whether the spool would take up the compressive load. When the spool is shorter, then the housing has to compress before the spool shares the compressive force. (Blanco Tr. at 1246, 1247).

215. It is the opinion of Prof. Blanco that a person who is skilled in the art would know that the functions specified in the patent must be complied with by having approximately the same length for both the spool and housing and having some compliance in the gasket take care of any tolerances between the two members. (Blanco Tr. at 1247, 1248).

216. The use of the housing as a return path enables making a meter compact. Anything that can increase the density of flow across the tube would

improve the efficiency of the system and would allow one to make it more compact. The housing as a return path does that. (Blanco Tr. at 1252).

217. The use of the housing as a load sharing element makes the F&P flowmeter also compact. Also the shape of the coils and a flangeless flowmeter help make the meter compact. (Blanco Tr. at 1252, 1253).

218. The use of housing as a magnetic return path has been known at least since the 1960s and has been used in a wide variety of electromagnetic flow meters. The use of thin coils has long been known before the '982 patent. The use of thin coils is not a feature of the invention claimed in the '982 patent. (Blanco Tr. at 1253, 1354).

219. For many years there has been very few things "unique" in mechanical engineering. That applies to everything, not only to flowmeters. (Blanco Tr. at 1256).

220. There are a variety of forms of the F&P MINI-MAG flowmeter. One variety has bolt holes extending through the body of the meter itself or through an extension of the diameter of the housing and another form has bolt holes that do not extend through the body of the meter. The principles are the same in both. The two forms are both compact electromagnetic flowmeters. (Blanco Tr. at 1257, 1258; CX-37 at 2).

221. German patent 2,040,682 does not show a housing of any kind surrounding a flow tube. (Blanco Tr. at 1265). As to the Krohne flowmeters CPX-23 and CPX-24, Prof. Blanco only determined the bonding or the force with which the spool was held inside the housing. He did not crush the housing. He tested to see if the housing material was ferromagnetic. When asked where as to CPX-23 whether he made a determination whether the magnetic return path defined a magnetic circuit, with the coils, he testified that in CPX-23, coils

are above and below the spool and surrounding the spool is a ferromagnetic material which obviously is the type of path that the magnetic flow would follow. With respect to Krohne CPX-24, the housing is the entire blue element. (Blanco Tr. 1269, 1270, 1271).

222. In the Khrono CPX-24, a cylindrical section of the housing lie within the the circle of bolt holes of the flanges. There are two protruding sections of housing above and below that lie outside the circle of bolt holes. (Blanco Tr. at 1271).

223. In a video tape (CPX-35) the computer program was prepared by John Herschtag, the director or manager of the computer aided program at MIT. The information that he used was the information provided by the cutaway section of a Krohne meter which was given to him by Prof. Blanco. The question Prof. Blanco put to the director was to display what would happen if the housing had not been shrunk fit against the spool and another question was what would happen if the housing was slightly larger in the inside than the outside of the spool. A program was then prepared which would depict the situation as it really happened under those two conditions. (Blanco Tr. at 1272).

224. The video showed a diagram of a flow meter assembly comprising a pipe flange. Next to the pipe flange was a gasket and next to the gasket was a ceramic inner cylinder with the the pipe flange touching the ceramic inner cylinder through the gasket. Surrounding the ceramic inner cylinder was the cylindrical housing which was not touching the pipe flange. The inner diameter of the housing was set equal to the outer diameter of the ceramic inner cylinder. Another diagram showed the close-up of a corner of the ceramic inner cylinder, gasket and the cylindrical housing. A load was applied which simulated a load being applied through the flange and the gasket

to the inner ceramic cylinder. As the load is increased there is seen the load sharing distribution by the inner ceramic cylinder and the cylindrical housing. Thus when a total load of 10,000 pounds was dialed in, the inner cylinder carried 6500 pounds and the outer cylindrical housing carried about 3500 pounds for an overall ratio of about 2 to 1. Thus the outer cylinder carried about one third of the total load. In a second example the dimensions were altered so that the inner ceramic cylinder was slightly smaller in diameter than the outer cylindrical housing cylinder. There resulted a slight gap between the inner ceramic cylinder and the outer housing cylinder. When a load was applied initially only the inner ceramic cylinder carried the load. However as the load is applied the inner cylinder expanded and eventually the ceramic inner cylinder touched the outer housing cylinder and at this point the outer cylindrical housing begins to carry a load as well. The spool moved in about 200 micro-inches, i.e. that was the distance from the flange to the final position of the spool. In a load situation of about 14,000 total pounds the inner cylinder carried about 12000 pounds and the outer cylinder approximately 2000 pounds. Thus the housing carried about one-sixth of the load. However as the load was increased the percentage carried by the housing increased. Thus with a 20,000 total load, the housing carried more than one-fifth the total load. (CPX-35; Blanco Tr. at 1284, 1285). A transcription of the video tape reads:

Diagram shows the flowmeter assembly, over here is the flange at the right end next to it is the black gasket followed by the white inner cylinder made of a ceramic aluminum oxide and the housing in gray. Over here we can see that the inner diameter of the housing is set equal to the outer diameter of the ceramic inner cylinder.

This diagram shows a close up of the corner of the ceramic inner cylinder and the housing and what we're going to do here is apply a load which simulates the load being applied to the flange and the gasket to the inner cylinder shown by this black arrow here. As the load is applied, we see the reaction that forces this display, in white the force carried by the inner cylinder and in gray the force carried by the housing, load carried by the housing and as we increase the load here we see the load sharing distribution by the housing and the inner cylinder.

At this I'm going to dial in a load here of say 10,000, 10,000 pounds and at 10,000 pounds coming in we see that the inner cylinder carries 6500 pounds and the outer cylinder carries about 3500 pounds. Over here we see a load 10,000 pound total load, the inner cylinder carries approximately 6500 pounds the outer cylinder carries approximately 3500 pounds for an overall ratio of about two to one between the inner cylinder and the outer cylinder. So the outer cylinder carries about a 3rd of the total load. In this second example, I've changed the dimensions so that the inner cylinder is slightly smaller in diameter than the outer cylinder, so we see that small gap in there. In this case, when I apply the load, initially only the inner cylinder carries the load but as the load is applied the inner cylinder expands as you can see right up there, and eventually the inner cylinder touches, expands to touch the outer cylinder, at this point, the outer cylinder of the housing begins to carry a load also. As we see there. So at this particular loading situation we have about a 14,000 pound, 14,000 pounds coming in. The inner cylinder carries about 12,000 the outer cylinder approximately 2.

This diagram shows magnification factor of 2500 applied to the displacements in the axial and in the radial direction. A menu showing the material properties the modulus of steel set currently to 30 million, the modulus of ceramic aluminum oxide set about 54 million, and poisson's ratio of the ceramic set 0.3.

In this example, I've altered the dimensions so that the inner cylinder is slightly smaller than the housing, when you see the slight gap between them. As I apply a load here initially all of



the load is carried by the inner ceramic cylinder only, however, you see it expanding over here so that it eventually touches the outer housing and the housing begins to carry a load as well. And at this particular point we have a load of 14,000 pounds total of which 12,000 is carried by the inner cylinder and about 2,000 by the housing. We could say that the housing carries approximately  $1/6$ -- $1/7$  of the load, however, as we increase the load the percentage carried by the housing will increase so that here we'll be up to 20,000 pounds. And now we see that the housing carries more than a 5th of the load. When I get down here it's actually now or probably about 200 micro inches, I'm just guessing. OK, let's say it's about 200 micro inches around here. You want me to show this and

225. Mr. Hershtag made no allowance for possible temperature differentials between the ceramic core and the outer housing. A difference in the coefficients of thermal expansion would make the point of contact, when the housing is compressed, occur at a difference length along the axis. Prof. Blanco testified that if there is any heat affecting the function of the relationship between the spool and the housing it must be from a hot fluid passing through the inside of the spool with the heat coming from the fluid that is being processed. In that case, the most likely element to expand would be the ceramic spool and hence it would press even harder against the steel housing until there is an equalization of temperature. Prof. Blanco assumes that only the flow tube expanded and the housing did not because the outside of the housing is a good conductor which will be taking most of the heat out and there would be a tremendous delta-T between the inside and the outside of the housing. The temperature gradient across the wall of the spool is bound to be greater than across the wall of the steel housing when a hot liquid flows through the flow tube so it is most intuitive that the steel of the housing will not expand as much as the wall of the spool assuming the

difference in the coefficients of expansion is not too great. Prof. Blanco testified that a temperature differential test would make the actual test performed more dramatic because there is more space between the housing inside and the outside of the spool when they are both cold. If a cold liquid flows through the flow tube the flow tube will contract and there will be less force pressing between the spool and the inner wall of the housing. Prof. Blanco assumed that the design of the Krohne meter has been made in such a manner as to guarantee that under a variety of temperature conditions and fluid conditions there will be the necessary force between the inner tube and the outside tube and the purpose of the video tape (CPX-35) was to prove that there was a substantial transfer of force between the spool and the outside. Prof. Blanco could create an experiment in which he would proportion the inside diameter of the housing and the outside diameter of the spool and compute the function in such a way that he could produce almost slip fit i.e. he could push the spool inside and outside in certain ranges of temperatures. Prof. Blanco doesn't believe that the design of the Krohne flowmeter was to allow the spool to move in relation to the housing under any conditions. Prof. Blanco presumes that the Krohne system has been designed so that conditions which are unfavorable and which he could produce voluntarily i.e. having the spool move under certain temperature ranges and under the effect of a certain fluid etc.were not design goals of the Krohne flowmeter. According to Prof. Blanco it is not desirable to have the spool move freely inside of the housing. Hence it is assumed that the shrink fit that the flow meter has, and it has a considerable shrink fit, is enough to guarantee that under the normal temperature differences and the normal gradients between the inside and the outside of the spool there will always be a substantial force transmitted

between the spool and the housing. (Blanco Tr. at 1276, 1277, 1278, 1306, 1310, 1311, 1312, 1313).

226. Press fitting means that the housing surrounding the steel sleeve is slightly smaller in diameter than the spool that is put inside so that the spool has to be forced inside or pressed in. Alternatively the housing can be heated until it expands sufficiently, so that the cooler spool can be put inside and then when the housing cools down it compresses and grips against the surface of the spool. (Blanco Tr. at 1274).

227. Prof. Blanco testified that in the British Sybron patent some load could be transmitted to the cover under some conditions. However the load transferred would be extremely minor because the cover is a thin strip of stainless steel and if one puts too much of a load on that material it would "eventually, very rapidly" collapse or buckle. (Blanco Tr. at 1286, 1287, 1294).

228. In the Sybron patent, Prof. Blanco testified that the strip or cover fits in a groove around the inner edges of the flange. He was referring to the language of the Sybron patent which states that the "grooves 15 and 20 provide for receiving the long edges of a rectangular stainless steel strip (not shown in Figure 3) the width of which is the distance between the grooves 15 and 20 and the length of which is the circumference thereof." He also testified that the language of page 2, lines 75-86 of the British patent shows that the cover only serves to protect from the outside; that the cover is being folded almost like a sheet of cardboard. (RX-172 at 2, lines 41-46; Blanco Tr. at 1290, 1294).

229. Prof. Blanco testified that the word "seated" in claim 3, line 55 of the British Sybron patent means laying or supported by the little grooves all around. (Blanco Tr. at 1297).

230. In the British Sybron patent, according to Prof. Blanco if one took the cover off, the flowmeter would still operate the same way as with the cover. A housing cannot be taken off because it is a functional part of the system. (Blanco Tr. at 1298).

231. Joining parts means that the parts are in contact and the force applied to one part is transferred to the other part. (Blanco Tr. at 1300).

232. The cover in the British Sybron patent is not in any way transferring large physical forces from the spool because it doesn't have the strength to resist it. (Blanco Tr. at 1301).

233. According to Prof. Blanco, a cover in the British Sybron patent 1,424,875 may be joined to the spool and still the cover would not do very much strengthening of the spool because it is meant to be a cover and not meant to be a structural member with the important distinction being that a cover, not being a structural member, can be removed. The cover can be removed from the Sybron transducer and the transducer will work exactly the same as it did with the cover. In contrast a structural member supports something else. It cannot be removed. It is part of the system of resisting forces. It is intended for that purpose. (Blanco Tr. at 1301, 1302).

234. The housing in the '982 patent is resisting forces. It is positioning members. It is protecting the flowmeter and it is forming part of the magnetic return circuit. The cover in the Sybron British patent is not intended to form part of the magnetic return circuit because it is a stainless steel which is commonly a nonmagnetic material. (Blanco Tr. at 1302, 1303).

235. The three characteristics that are really critical in the '982 patented flowmeter are the transfer of the load between the spool and the housing, the strengthening that the housing gives the spool and the fact that

the housing acts as a magnetic return path. There may be another as the housing shielding the unit against external electromagnetic and electrostatic influences to prevent electrical noise i.e. perturbations that could affect the performance of the instrument. (Blanco Tr. at 1304).

236. According to Prof. Blanco if the cover is removed from the Figure 7 embodiment of the Sybron patent, the compressive strength, magnetic circuit, magnetic shielding or the operation of the flowmeter would not be affected. The reason for this is the cover is not a working element of the invention of the Sybron patent. The cover has no magnetic purpose because it is made out of stainless steel. Also the cover is so thin that if it has any strength it is very little. (Blanco Tr. at 1315, 1316, 1318, 1319).

237. According to Prof. Blanco and referring to the '982 patent and its Figures 6 and 7, if the housing was removed, the compressive strength, the strength of the magnetic circuit, the magnetic shielding and the operation of the flowmeter would be affected. The flowmeter would not work. Moreover it is physically impossible to remove the housing because then the spool would be floating in the air. Without the housing, there would be no return for the magnetic lines of flow and the compressive strength of the unit would be lost. The spool is forced to withstand the pressure of the fluid flowing in the conduit as well as the compressive force. In the absence of a housing there will also be a very poor magnetic field across the tube where the maximum intensity is needed because the bolts around the flanges will affect the distribution of the lines of force. In addition would be no electrostatic shielding. (Blanco Tr. at 1316, 1317, 1319, 1320, 1321, 1322, 1327).

238. Mr. Bela G. Liptak was qualified as respondents' expert in the field of process control in general and flow measurement and control of

flowmeters of all sorts, including magnetic flowmeters. (Liptak Tr. at 1333, 1334; RX-3).

239. According to Mr. Liptak, the '982 patent discloses a wafer-type electromagnetic flowmeter. By "wafer-type" Mr. Liptak is meant an electromagnetic flowmeter which is inserted between flanges in a bird cage type arrangement as in CPX-21 and CPX-36. Wafer is shown in Figure 3 of RX-3 at 11-12. (Liptak Tr. at 1335).

240. Mr. Liptak is of the opinion that the term "flangeless" is a misnomer because if the outer perimeter of the flange of the CPX-22 flowmeter is removed, there results a small flange. He prefers the term "wafer." (Liptak Tr. at 1337).

241. Mr. Liptak is the editor and one of the authors of Instrument Engineers Handbook. (RX-150).

242. Wafer-type (flangeless) flow meters comprise orifice type flow meters which are the oldest flow meters used in various industries. (Liptak Tr. at 1339, 13340, 1341).

243. U. S. patent no. 3,875,969 ('969 patent) discloses a target flow meter which is a wafer type flow meter sandwiched between flanges. There is a bird cage structure in figure 1 of the patent which is identical to what is shown in CPX-21 and CPX-36. The '969 patent on its face is assigned to The Foxboro Company and it is titled "Alignment Sleeves For Flangeless Flowmeters and the Like". It issued on April 8, 1975. (RX-173; Liptak Tr. at 1346, 1347).

244. The British Sybron patent discloses a wafer-type electromagnetic flowmeter to be installed in a bird cage type installation as shown in CPX-21. Bird-cage means that the complete flowmeter is inside the bolt circle

of the pipeline flanges. Mr. Liptak considered the British Sybron patent the most pertinent reference to the '982 patent because most features that are in common with the '982 patent is found in the British patent. In his opinion the spool in the British patent is strong enough to take up the compressive forces generated by the pipeline flange bolts, and there is a compact wafer type device that is inserted between the bolt circle of the pipeline flanges. There is also a cover in the British patent which in the opinion of Mr. Liptak is used in an identical manner as the "cover" he sees on CPX-29. (Liptak Tr. at 1351, 1352).

245. Mr. Liptak sees no teaching in the '982 patent that the loads are to be shared between the housing and the spool. To Mr. Liptak, the terms "join" and "mate" imply that the cover or housing is not intended to get loose. Mr. Liptak is of the opinion that the terms "cover" and "housing" are used interchangeably in the flowmeter industry. (Liptak Tr. at 1352, 1353).

246. Mr. Liptak testified that when compressive forces are applied to the Figure 7 embodiment of the British Sybron patent from the flanges of the pipe the forces are applied to the spool. According to Mr. Liptak the housing or cover and the spool in the Sybron patent are physically in contact. Mr. Liptak refers to the language of the British patent which states. "The grooves 15 and 20 provide for receiving the long edges of a rectangular stainless steel strip 26 . . . the width of which is the distance between the grooves 15 and 20 and the length of which is the circumference thereof." (Page 2, lines 41-46). Mr. Liptak testified that the width is the distance between grooves and therefore the cover and spool are touching. For touching Mr. Liptak also relies on the language "An electromagnetic flow transducer . . . wherein said annular space is covered by a cylindrical cover seated on the peripheries of the flanges and extending from one flange to the

other flange and all the way around said peripheries." (RX-172 at 3, lines 53-58; Liptak Tr. 1362, 1363, 1364, 1365).

247. In Figure 6 of the Sybron British patent the cover 126 is shown with cross-hatching. (Liptak Tr. at 1366).

248. The language in the British Sybron patent "The junctures of the long edges and the grooves 15 and 20 are preferably sealed by any suitable means . . . in order to keep the flowing material in the main l from getting into the annular space between the flanges 11, 12, the inside of the strip 26 and the part 18 of the tube 9" (at 2, lines 50-56) is not absolutely clear. It is possible that the language is referring to the juncture identified as part 33 in Figure 6. (Liptak Tr. 1368, 1369).

249. Brochure for Krohne's ALTOFLUX X-1000 states that the flowmeter is a matchless instrument in terms of resistance to pressure, temperature, abrasion and corrosion. The chemical and physical resistance properties of the measuring section is said to make the flowmeter suitable for virtually any application. (CX-29 at 1, 2).

250. Mr. Liptak testified that the ceramic spool in the British Sybron patent can be made strong enough by the average engineer to stand up to compressive forces in the low thousands and high hundreds. It is only a matter of selecting the right wall thickness. (Liptak Tr. at 1375, 1376).

251. It is Mr. Liptak's position that in Figure 3 of the British Sybron patent the cover is in physical contact with both the horizontal surface and the vertical surface of the groove. Gravity will cause the touching on the horizontal surface. The conclusion that the cover is touching the vertical surface is based on the language at page 2, lines 41-46 and page 3, lines 53-58 of the British Sybron patent quoted in findings 246. (Liptak Tr. at 1377, 1378).



252. According to Mr. Liptak in Figure 7 of the British Sybron patent the cover is touching the spool. (Liptak Tr. at 1379, 1380).

253. According to Mr. Liptak, a cover or a housing is not a load-bearing element. Neither the British Sybron design nor the '982 design, Mr. Liptak testified, is dependent upon the cover or the housing to serve to support against compressive forces. He testified in both the Sybron and the '482 designs the inner spool serves that function; that the purpose of the housing or the cover is to protect the components inside from environmental effects. Mr. Liptak testified that the terms "joined" and "mated" are not intended to mean that the parts joined or mated are intended to share in the compressive force because all housings have to be joined or otherwise that would be loose; and that the electrical components in the beige colored cover on top of CPX-21 is in a housing which is joined but which has nothing to do with the '982 patent. Mr. Liptak testified that the fact that a housing is joined to another part serves only to make certain that the housing does not fall off and to provide a strong seal so that no environmental vapors can get in. (Liptak Tr. at 1381, 1382, 1383, 1384). However he also testified that if the cover in the British Sybron patent is in physical contact with the spool therein, compression force applied to the spool can be transferred to the cover and that this would be apparent to those skilled and even not skilled in the art. (Liptak Tr. at 1362, 1476, 1477, 1478).

254. According to Mr. Liptak, the main function of the housing of F&P CPX-29 is to keep the coil and the associated wiring and electronics protected from the outside environment. It also has the function of providing an electromagnetic return path for the magnetic field. (Liptak Tr. at 1385, 1386).

255. Mr. Liptak testified that in instrumentation and process control he would be hard pressed to find a pressure gauge where the housing bears any load whatsoever and where the housing has no other purpose but to protect the pressure measuring device. Reference was made by Mr. Liptak to the beige coloring device on CPX-21 which contains electrical components. (Liptak Tr. at 1387).

256. Mr. Liptak knows of some electromagnetic flow devices where a housing would have the functional purpose of sharing the load but the meters are not in issue in this investigation according to Mr. Liptak. An example is at page 481 of RX-150. (Liptak Tr. at 1388, 1389).

257. Mr. Liptak testified that there are some very good reasons why it would be bad engineering design to put compressive forces on the housing intentionally; that a housing made out of cast iron would break or would crack because cast iron is a very brittle material; that cast iron, in such a thickness as shown in CPX-23, can be damaged if compressive pipeline forces are transmitted to it in substantial quantities; that an engineer will not depend upon the availability of a support which can disappear under certain conditions; that manufacturing tolerances e.g. the interface between the Krohne CPX-23 outer shell and the inner spool, may vary and then the availability of the support provided by the housing will vary; and that a good engineer will not depend upon a variable to guarantee a permanent solution to anything; and that temperature conditions will cause the same effect. (Liptak Tr. at 1389, 1390, 1391).

258. Mr. Liptak testified that the following portions of the '982 patent:

The housing in this related case is formed by complementary half-pieces which include end plates that join the corresponding ends of the spool to define the inner chamber. (col. 2, lines 41-44).

. . .

Surrounding the spool and concentric therewith is a cylindrical housing fabricated of ferromagnetic material and formed of complementary half pieces which include arcuate end plates that join the corresponding end flanges of the spool to define an enclosed inner chamber. (col. 3, lines 54-59).

. . .

Surrounding the lined metal spool 10 and concentric therewith is a split cylindrical housing or casing formed by complementary half-pieces . . . , the longitudinal edges of these pieces being seam welded or otherwise joined together to complete the housing. (col. 4, line 50-54).

. . .

The opposite ends of the split housing are provided with annular closure plates 22 and 23 whose inner peripheries mate with the outer peripheries of end flanges 10A and 10B of the spool to define an enclosed inner chamber in the space between the spool and the housing. (col. 5, lines 22-28).

relate to making sure that the housing does not get loose, that it is kept in position, that the housing (as in CPX-23) does not shift around the ceramic spool and damage the wires. (Liptak Tr. at 1394, 1395, 1396).

259. With respect to clause A of claim 1 of the '982 patent, Mr. Liptak understands the claim to mean that the unit will "withstand" the compressive forces with the unit consisting of four components with the spool meeting the test, and the electrodes, housing and coils not meeting the test. Mr. Liptak gave no explanation why the housing would not share the compressive force. (Liptak Tr. at 1396).

260. Mr. Liptak testified that "said compressive force" in clause B of claim 1 refers only to the spool. (Liptak Tr. at 1397).

261. F&P CPX-29 operates according to Faraday's principle which says that if a magnetic field is imposed upon a moving conductive fluid, that an electromagnetic force will be generated which can be measured by an electrode,

and which force is proportional to the velocity of the flowing fluid. Mr. Liptak testified that the operation of the British Sybron flowmeter is identical in that respect. With the MINI-MAG and flowmeter of Sybron Liptak testified, on compression, forces are transferred to the housing or cover and that it is a matter of design how much of the forces might be transferred. In neither design would Mr. Liptak consider it good engineering practice to depend upon the housing to take any share whatsoever of the compressive force on a permanent basis because that support may or may not be available all the time and good engineering design requires that anything one depends upon should be there all the time. The only difference in the force transmission mechanism in the two devices is that in one a teflon liner is interposed between the pipeline flange gasket and the spool while in the other the pipeline flange gasket rests directly on the ceramic spool. On physical contact of the housing or cover with the spool there is a transfer of compression force. (Liptak Tr. at 1400, 1401, 1405).

262. Mr. Liptak testified that ceramics are extremely strong in compression so there is no reason whatsoever to share the load. (Liptak Tr. at 1401).

263. Mr. Liptak testified that the housing on Krohne's CPX-23 is malleable iron and hence cannot be exposed to excessive forces. The housing in F&P's CPX-29 is said to be not as brittle. Mr. Liptak testified that the difference in material would not make any difference as to whether the housing or cover acts or does not act as a force transmitting element. (Liptak Tr. at 1407, 1408).

264. The British Sybron patent discloses a flangeless electromagnetic flow meter unit interposable between the end flanges at the upstream and

downstream pipes of a line conducting a fluid whose flow rate is to be metered. The end flanges of the pipe have a predetermined diameter and a circle of bolt holes. According to Mr. Liptak the electromagnetic flow meter unit comprises a cylindrical metal "housing" (component 10 on Figure 7) which has an external diameter smaller than that of the circle of bolt holes such that when the unit is interposed between the end flanges of the pipes, the housing lies within the circle of bolt holes. (Liptak Tr. at 1410, 1411).

265. According to Mr. Liptak in the Sybron British patent the flanges bridged by bolts passing through the holes engage the flow meter and subject it to a compressive force effecting a fluid seal. There is also a nonmagnetic spool coaxially disposed within the housing with the spool provided with end flanges which are seated against the ends of the upstream and the downstream pipes. Said flanges are said to define with the housing an internal cavity. (Liptak Tr. 1412, 1413).

266. Mr. Liptak testified that in the British Sybron patent the spool forms a fluid conduit having a longitudinal flow axis which joins the upstream and downstream pipes and that the spool has a strength sufficient to withstand the pressure of fluid flowing in the conduit and the compressive force. The compressive force is said to be applied to the spool of the meter. In the British Sybron patent there is a pair of electromagnet coils disposed at diametrically opposed sides of the spool which create a magnetic field whose lines of flux extend across the conduit. In the Sybron British patent a pair of electrodes is mounted on the spool at diametrically opposed positions. The electrodes lie along an electrode axis perpendicular both to the coil axis and to the flow axis. (Liptak Tr. at 1415, 1416, 1417).

267. Mr. Liptak testified that in the Sybron patent coils are dispersed in the cavity and that coils are saddle-shaped (bundles of wire shaped to

form to the outer surface contour of the pipe on which they are seated).

(Liptak Tr. at 1418, 1419).

268. Liptak testified that at page 481 of RX-150 the housing is formed of ferromagnetic material which joins the electromagnet coils to define a magnetic circuit. (Liptak Tr. at 1419, 1420).

269. Mr. Liptak was of the opinion that the British Sybron patent is the most relevant patent to the '982 devices and in his view the device described in the '982 patent would be obvious to one skilled in the art of electromagnetic flowmeters, viz. an average engineer who is familiar with the basic features of the electromagnetic flowmeters such as kinds of coils, spools, housings, and the methods for returning the electromagnetic flux. (Liptak Tr. at 1421, 1422).

270. Mr. Liptak believes that a typical flowmeter installation could have a maximum compression force of 10,000 pounds. (Liptak Tr. at 1429).

271. An average engineer would be able to select the right spool wall thickness to match the forces acting on it. (Liptak Tr. at 1430).

272. The strap in the British Sybron patent is said to serve the dual function of holding the coils in place and also to return the magnetic flux or complete the magnetic circuit. (Liptak Tr. at 1432).

273. The word "compact" is a relative term. It usually refers to the previous state of the art and suggests that the particular device in question is smaller in some or all of its dimensions relative to its predecessors. Mr. Liptak is of the opinion that the Mag 10D 1435 flow meter is more representative of prior compact electromagnetic flow meters than the flow meter of CPX-22. The Mag 10D 1435 in CX-40 is for a meter size between six inches and 48 inches. F&P CPX-22 is for three inches. The inches refer to

pipe size i.e. the diameter of the pipe which is the center section of the flow meter. CPX-29 has the same pipe size as CPX-22. The Krohne CPX-23 has the same pipe size as the F&P CPX-29 and CPX-22. (Liptak Tr. at 1438, 1440, 1442, 1450, 1451, 1452; CX-40 at B24).

274. The flow meter of the German patent 2,040,682 does not have a housing which would serve any function. It does not have a separate spool and a separate housing or cover. (Liptak Tr. at 1442, 1443).

275. Mr. Liptak testified with respect to the F&P 3 inch CPX-29 flowmeter that if there are compressive forces acting on the spool and the spool is engaged from both ends, and the housing is in physical contact with the spool there will be transmission of forces. Mr. Liptak knows that in practice in the F&P flowmeter the spool is welded to the housing. (Liptak Tr. at 1462, 1463).

276. In the Krohne CPX-23 flowmeter the housing is shrunk fit onto the spool. When it is made by thermal shrinking of the outside iron, the purpose of shrinking is to hold the spool in place and therefore there is some contact between the housing and the spool. The rigidity of the contact is a subject of manufacturing tolerances and operating temperatures. Mr. Liptak agrees that in the Krohne flowmeter the housing is intended to be in contact with the spool. There is no loose fit of the housing and spool in the Krohne meter. (Liptak Tr. at 1463, 1464, 1465, 1466, 1467, 1468, 1472, 1474).

277. Mr. Liptak understands that the Krohne CPX-23 flowmeter is intended to be used in conditions where the temperature may vary and in all of the temperature variations the spool will remain enclosed by the housing. It would be an undesirable occurrence for the spool to be loose. (Liptak Tr. at 1471, 1472).

278. It is correct that there is not a word in the British Sybron patent that if a force is applied to the spool it will be applied to the cover. (Liptak Tr. at 1478).

279. The British Sybron patent discloses a thin strip of stainless steel for use as the cover. (Liptak Tr. at 1479).

280. The force to which the inner spool is subjected and the housing or cover receives through transmission is a function of the method of joining the housing to the spool. (Liptak Tr. at 1481).

281. If a ceramic tube is placed between the jaws of a vice it is then being subjected to a compressive force. Cast iron is probably less brittle than ceramic. Ceramic is a brittle material and it cannot be subjected without breaking to an extensive amount of tensile force. Ceramic is weak to tensile forces. Tension and bending forces are used interchangeability. (Liptak Tr. 1482, 1483, 1484, 1485).

282. Ceramic is weak to bending forces. (Liptak Tr. at 1488).

283. Theoretically a fluid exerting a radial force of up to 600 pounds per square inch would have the tendency of causing a ceramic flow tube to bulge outwardly. However if the spool was made strong enough the bending could be prevented. The tube could be made thicker. (Liptak Tr. at 1492, 1498, 1499).

284. If forces exceed the ability of a ceramic tube to retain its shape so that the internal forces cause it to bulge, the material then comes into tension and in tension ceramic is weak. (Liptak Tr. at 1502).

285. When bolts that engage an electromagnetic flowmeter are tightened the flanges exert a compressive force on the spool and as the force is applied to the spool at least a part of that force is transferred to the housing if



the housing is connected to the spool. If the housing is connected to the spool and the flanges are not exactly parallel, at least to a limited extent, it is possible that the housing will help prevent the ceramic flanges from cracking. Mr. Liptak agrees that the housing on either the Krohne CPX-23 flowmeter or the F&P CPX-34 flowmeter which accommodates the ceramic spool would tend to prevent the breakage of the spool in a condition where the pipe flanges are skewed. (Liptak Tr. at 1516, 1517, 1518).

286. The orifice plate flowmeter at page 427 of RX-150, which Mr. Liptak referred to as a wafer-type meter, is not a magnetic flowmeter. It does not rely on magnetic fields. Any problem relating to any electrical or magnetic field lying in the pipeline in which the orifice meter is to be located is not a serious consideration. There is only one section in RX-150 which relates to magnetic flow meters. (Liptak Tr. at 1523, 1524, 1525, 1526, 1527, 1528, 1529).

287. The magnetic field, the strength of the magnetic field, the shape of the magnetic field are important considerations in the magnetic flowmeter. Bolts that engage the electromagnetic flowmeter can have an influence on the intensity of the magnetic field. The efficiency of the flowmeter could be damaged if the magnetic flux is returned through an unfriendly path. (Liptak Tr. at 1533, 1534).

288. A meter that can be made smaller, lighter and shorter coaxially is a meter which is more compact in size. (Liptak Tr. at 1541).

289. The '982 patent describes a flangeless or wafer type magnetic flowmeter which includes a metal housing, a flow tube consisting of a nonmagnetic spool protected by a nonconductive liner. The nonmagnetic spool is joined to the metal housing as is the spool joined to the metal housing in the Krohne magnetic flowmeter. (Liptak Tr. at 1544, 1545, 1546).

290. The '982 patent specifies that the coils are disposed in a cavity between the spool and the housing and that applies to the Krohne flowmeter CPX-23. The '982 patent specifies that the coils are saddle-shaped and that the housing is ferromagnetic and forms part of the magnetic circuit and that applies at least to the Krohne CPX-23 flowmeter. (Liptak Tr. at 1550, 1551, 1552, 1553).

291. Mr. Liptak has conducted no test of the Krohne flowmeter to determine whether the magnetic return path is primarily in the ferromagnetic housing as compared to the flux lines in the strap. (Liptak Tr. at 1553).

292. Liptak testified that he has asked the Krohne designers and have received very specific information on how much of the flux is carried by the Krohne magnetic strap and how much of it is returned through the housing and hence is fully satisfied that the overwhelming majority of the flux is carried by the strap and so he saw no need to look at either the permeability data or thickness data to make separate calculations on a subject matter "where there are such more knowledgeable than I am." Mr. Liptak did not identify the Krohne people and he presented no specific information that the Krohne people was said to have given him. He stated that the Krohne people gave him nothing in writing to show test data and that he had not seen any test data. Mr. Liptak did admit that the permeability of the material is relevant to the number of flux lines which the material is capable of carrying, that he did not know the permeability of the ferromagnetic housing used by Krohne as compared to the permeability of the strap material Krohne uses, and that the thickness of the ferromagnetic material is relevant to determining its efficiency in carrying flux. Mr. Liptak visually observed that the ferromagnetic housing of the Krohne meter is thicker than the strap of the Krohne flowmeter, that the

thickness of the two-piece strap is substantially less than that of the housing. (Liptak Tr. at 1554, 1555, 1556, 1557).

293. Mr. Liptak testified that he is fully satisfied with what the Krohne designers told him to the effect that the majority of the flux in the Krohne flowmeter is carried by the strap on the basis that the British Sybron patent 1,424,875 is provided with the same kind of strap; that the Sybron design is unassisted by any ferromagnetic housing and is still functioning perfectly well with the strap alone as the means of completing the magnetic field. He testified that he has purchased a large number of Taylor flowmeters and has seen those flowmeters installed, calibrated and operating. Liptak testified that the Sybron meter was the first commercial magnetic flangeless flowmeter that used a spool shaped tube; that the magnetic flowmeter which Mr. Liptak is familiar with and which he refers to as the Taylor flow meter is the Sybron device and that the Taylor flowmeter has been manufactured as in the configuration shown in the Sybron patent, Figure 1. (Liptak Tr. at 1557, 1558).

294. Mr. Liptak is not sure that the F&P flowmeter of the '982 patent is the first flangeless magnetic meter with a ferromagnetic housing in commercial practice. Mr. Liptak admitted that in his book Instrument Engineers' Handbook (1969) or its revised edition (1982) (RPX-3) there is no illustration of the Sybron meter although in both books it was Liptak's intention to illustrate and describe those meters which were in commercial practice. Mr. Liptak testified that the device at page 486 (Fig. 5.8f) of RX-150, while it is a generic type illustration, is in all respects identical to Figure 1 of the British Sybron patent. (Liptak Tr. at 1557, 1559, 1560, 1561, 1562).

295. Pages 485-486 of RX-150 states in part:

The "Pitot" type magnetic flowmeter is a magnetic flowmeter that samples the flow velocity in large rectangular, circular, or irregularly shaped pipes or conduits. A typical design is shown in Figure 5.8f. A small size magnetic flowmeter is suspended in the flow stream. The magnet coils are completely encapsulated in the liner material therefore, the magnetic flowmeter can be submerged in the liquid to be measured. The short length of the meter body and the streamlined configuration are designed to minimize the difference of flow velocity through the meter and the velocity of the fluid passing around the meter. The velocity measurement of the liquid through the meter is representative of the pipe velocity. Repeatability of the system is typically 0.25 to .5% of full scale.

Fig. 5.8f is represented as follows:

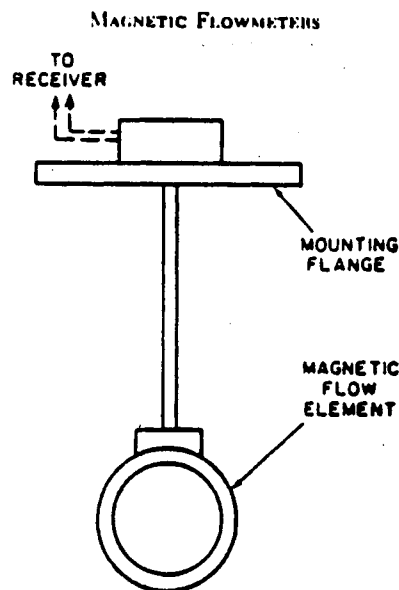

Fig. 5.8f The pitot type magnetic flowmeter

There is no indication in Mr. Liptak's handbook who made the "Pitot" type magnetic flowmeter. The handbook was copyrighted in 1969 and the first patent application on the Sybron patent disclosure was not filed until June 19, 1972 in the United States. (Liptak Tr. at 1564, 1565).

296. When Mr. Liptak was asked whether he was aware of any commercial magnetic flowmeter prior to the F&P flangeless magnetic flowmeter (CPX-29) which incorporates the combination of the ferromagnetic housing and a spool-shaped flow tube within such housing where the housing performs the magnetic return path function, Mr. Liptak testified that "I have already answered that I am not aware of any such combination of features which does not exclude the possibility that there were." (Liptak Tr. at 1568).

297. In the Krohne meter (RX-3, Figure 1) it is rather important that the coils be precisely located because of their relative position to the electrode. In the process of manufacture of the Krohne meter, the housing as a result is heated and as a result the housing expands and then the spool is located inside the expanded housing. Thereafter in the cooling process, the housing shrinks on the spool/coil combination. In the Krohne meter it is important that the coils' position relative to the electrodes be maintained. Mr. Liptak does not know what secures the coils in position on the spool other than the strap in the Krohne device. (Liptak Tr. at 1577, 1578). In the Krohne flowmeter after the housing is shrunk onto the spool/coil assembly the load which is applied to the spool is transferred to the housing in part because of the tight fit between the housing and the spool. (Liptak Tr. at 1578, 1579).

298. The illustration at page 481, RX-150 (Handbook) does not suggest a spool-shaped tube in the housing. Figure 1 of the Mannherz patent (CX-116) is essentially the same as Figure 5.8(c) of RX-150 (page 481). Figure 5.8(c) does not show a flangeless or wafer-type configuration. It does not teach one skilled in the art to use a spool-shaped tube in combination with a flangeless housing. The insulating liner in Figure 5.8(c) is not characterized as a spool. (Liptak Tr. at 1586, 1587).

299. The Ketelsen German patent 2,040,082 has not been commercialized. It is not illustrated in the Liptak Handbook (RX-150). (Liptak Tr. at 1596, 1597).

300. With respect to the "Pitot" type magnetic flowmeter (page 485 of RX-150), Mr. Pitot was an individual who invented the Pitot tube. The Pitot tube is a particular type of flowmeter which over the decades became a generic term referring to all flow meters which look at one point on a cross section of a pipe and at the flowing velocity at the one point in the total cross section and then assumes that the total flow can be estimated on the basis of that partial measurement. (Liptak Tr. at 1598).

301. In the Pitot arrangement the inner and outer surface of the flow element are exposed to the same pressure. (Liptak Tr. at 1599).

302. The Figure 1 flowmeter of the Sybron British patent is not subjected to compressive forces. (Liptak Tr. at 1600).

303. In the hearing the testimony was:

Q. Would you now turn to page 73, at line 18 [of Liptak deposition] Are you there, sir?

A. Yes.

Q. "What is the function of the Cover 10 in Figure 7 of the Sybron patent?"

A. "What is the function? Mechanical protection."

Q. "Mechanical protection of what?"

A. "Of the wires and the coil inside."

Q. "Is that all?"

A. "Yes."

Q. "Did you give those answers to those questions, sir?"

A. "Yes, I did, and that last answer can be misinterpreted to suggest that the function of the Sybron housing is different in any way from the function of the 982 patent housing. It is not. It is the same function."

(Liptak Tr. 1603, 1604).

304. The cover in the British Sybron patent is stainless steel and therefore the cover in the Sybron patent is not part and cannot be part of a magnetic circuit because stainless steel is nonmagnetic. (Liptak Tr. at 1605).

305. The illustration in Figure 7 of the British Sybron patent would function the same with or without the cover from the point of view of the completion of the magnetic flux path. (Liptak Tr. at 1606).

306. The British Sybron patent does not teach Mr. Liptak that the cover is intended for any other purpose but for environmental protection. It does not teach him that the cover is a structural member supporting compressive forces. Liptak testified that under certain circumstances when the flanges come in physical contact with the cover, it can provide "substantial support because a stainless steel cylinder is extremely strong." (Liptak Tr. at 1607, 1608).

307. The cover in the Sybron patent in Figure 6 is shown as being bent around and then clamped at the bottom by a mechanical clamp which is 33. (Liptak Tr. at 1610).

308. The Sybron British patent reads:

The cross-sectional view of Figure 6 and also Fig. 5 show how the strip 126 has its short sides folded back in order that a channeled strip 33 may slip over there short sides in order to clamp the strip 126 into cylindrical form. (page 2, lines 77-82).

That sentence describes a sheet metal operation. (Liptak Tr. at 1611, 1612, 1613).

309. Mr. Liptak stated that the the next sentence following the quotation in finding 308, viz. "[i]n this instance, a fluid-tight seal between the strip 126 and the tube 109 is not necessary, since the transducer is not designed to be inserted bodily into a flow of larger cross-section than the transducer" does not "necessarily" describe the Figure 7 embodiment of the Sybron British patent although he admitted that in the Figure 7 embodiment the flowmeter or transducer is not designed to be inserted bodily into a flow of larger cross section. (Liptak Tr. at 1613, 1614).

310. The housing of F&P CPX-29 does not represent a sheet metal type configuration nor does the housing of Krohne CPX-23. (Liptak Tr. at 1615, 1616).

311. At the hearing Mr. Liptak testified:

Q. If you took the cover off the Krohne meter, would it affect the magnetic performance of that meter. CPX-23 again?

A. Slightly, it would affect its efficiency, sensitivity, and it would require the recalibration. If you have purchased the meter calibrated without the cover it would not affect it at all.

Q. Do you know whether Krohne sells its meter without the cover?

A. No, I don't think so.

Q. Do you know whether they sell this meter with a stainless steel piece-of strip - - let me put that into the English language. Do you know whether Krohne sells its meter with a housing made of a strip of stainless steel material?

A. I don't know that. I'm not aware of such model on the market.

Q. And it is your testimony that if one removed the housing from the Krohne meter, it would have only a slight effect on the magnetic performance of that meter?

A. Yes, sir. That is my testimony.



Q. Have you tried that, sir?

A. I have not tried it. I have discussed it with the Krohne design engineers, and that is what I have been advised by them, and I have no reason to distrust their information.

. . . .

Q. Did he [Krohne design engineer] tell you or did Krohne people tell you that they tested it, they tested the magnetic behavior of the meter after they removed the housing?

A. What they told me was simply that the distribution of magnetic flux is in large proportion in favor of the strap and the minority of it is passing through the housing, and based on my own experience and understanding of magnetic flow meter operation, I have thereby concluded that what it takes for a magnetic flow meter to operate without that housing is to recalibrate it so as to correct for the lessening of the strength of the magnetic field that has occurred due to that removal.

Q. My question to you, sir, is did they tell you that they tested the meter without the housing for its magnetic behavior?

A. No, they did not.

(Liptak Tr. at 1616, 1617, 1618).

312. If the housing were removed from the F&P meter it would have an effect on the magnetic behavior of the meter. (Liptak Tr. at 1618).

313. In the smaller Krohne CPX-24 flowmeter the housing lies outside the circle of bolt holes on the flanges (CPX-24A). The cavity of the flow meter in which the coils are placed lies outside the bolt circle of the pipeline flanges. (Liptak Tr. at 1630).

314. Krohne Technical Data for ALTOFLUX X-1000 and X-2000 at page 10, lower left hand side, shows CPX-24. The units extend from 2.5 to 40 millimeters. The majority of the housing is outside the bolt circle of the pipeline flanges. (CX-95 at Bates 500,561; Liptak Tr. at 1631, 1632).

315. The housing of the Krohne three-inch meter serves as the flux return path as in the case of the F&P flowmeter. Liptak testified that the magnetic strap serves as the major component for returning the magnetic flux lines and the housing serves as the minor path based on information received from Krohne people. (Liptak Tr. at 1634, 1635).

316. Mr. Liptak testified that in a manufacturing process no two units will have identical tolerances and that he was told that these tolerances have been substantially increased so as to reduce the force transfer because the housings were being damaged by pipe stresses. (Liptak Tr. at 1640).

317. According to Mr. Liptak, the superior design features for the Krohne flowmeters are due to the ceramic (aluminum oxide) flow tube, the high accuracy electronics, the fused platinum electrodes and remote range change capability. Because the Krohne ceramic spool surface has no cavities for bacteria to accumulate, the Krohne design is preferred for sanitary applications. Tefzel lined magnetic flowmeters are limited to 120 degree centigrade while Krohne's ceramic lined ones can operate sixty degrees higher. The thermal expansion of metals and plastics is much higher than of ceramics. The abrasion resistance of high purity aluminum oxide used by Krohne is exceeded only by diamond, while plastics such as Teflon, will have a limited life in such services as pulverized coal, lime or other solids. In applications where there is gamma radiation in the area, plastics such as Teflon will eventually fail while radiation does not affect the ceramic element of the Krohne aluminum oxide design. Finally Teflon cannot stand up to fluorine and sodium and Teflon is damaged by hot oxygen. Krohne's ALTOFLUX and DELTAFLUX magmeters further utilize a platinum electrode which is fused or sintered into the aluminum oxide ceramic liner. F&P MINI-MAG magnetic

flowmeters utilize tungsten carbide electrodes with tantalum or zirconium holders. Platinum provides better corrosion resistance than tantalum or zirconium. The fused electrode in the aluminum oxide design is permanent and rugged. (Liptak, CX-3, at 4-11).

318. The thermal expansion of metals and plastics is much higher than of ceramics. Therefore the aluminum oxide flow openings of the Krohne flowmeters will change much less with temperature than plastic lined metallic units. (Liptak RX-3 at 5-6).

319. Magnetic flowmeters are unaffected by changes in fluid density, viscosity, turbulence of the fluid, or by variations in piping. (RX-150 at 481).

320. The basic advantage of the magnetic flowmeter is that it is totally obstructionless and therefore has no moving parts. Pressure loss of the flowmeter is no greater than that of a piece of pipe of the same length. Pumping cost are minimized because there is no obstruction and because the fluid is not being manipulated in order to get a flow measurement. Electric power requirements are extremely low. The meters are suitable for most acids, bases, waters and aqueous solutions because the lining material selected are not only good electrical insulators but also are excellent materials for corrosion resistance. The meters are widely used for slurry services not only because that are completely obstructionless but also because delected liners have superb abrasion or erosion resistance. Also the meters can be used as bi-directional meters. (RPX-3 at 85).

321. Magnetic flowmeters work only with fluids which are adequate electrical conductors and they may be relatively heavy. (RPX-3 at 85).

322. Magnetic flow meters are traditionally the first type of flowmeters to be considered for very corrosive applications and for applications involving measurement of abrasive and/or erosive slurries. They are widely applied to pulp and paper stock measurement and other non-Newtonian fluids. (RFX-3 at 85, 86).

323. A November 7, 1980 Krohne internal report referred to a discussion on the X 1000 project on 11/5/80. It was stated that the X 1000 would be quite unusual small magnetic-inductance instrument that could operate with standard amplifiers. The design was to be unflanged if at all possible with liner made out of a piece of Alsinth (ceramic) or fiberglass-reinforced PTFE pipe. Under "Developing the device" it was stated "Exploiting all possible resources, in collaboration that is with the best Krohne-Group development people and possibly those of outside organizations.. No specific details of the construction of any meter are set forth. (CX-58).

324. A November 28, 1980 Krohne internal report refers to the goal of development to build a compact generator with ceramic cladding. Reference is made to a ceramic-oxide compound of aluminum oxide. The embodiment was to be unflanged if at all possible with liner out of a piece of ceramic pipe. The housing is to be below the connecting bolts if at all possible. For the larger flowmeters saddle coils are to be used. For the smaller flowmeters the conventional one or more flat coils are suggested. The electrodes were to be made out of a chemically resistant precious metal. (CX-59).

325. A Krohne internal memo dated March 17, 1981 about the X-1000 stated design when possible without flanges. It is further stated that the X-1000 compared to the new Fischer & Porter instrument" which is launched newly this month" is a much more sophisticated instrument. (CX-56).

326. The March 17, 1981 internal Krohne report about the X-1000 states that the metal "round housing is used as magnetic return path" and that if possible "this housing should be placed under the connection bolts." (CX-56 at 700055).

327. The Nov. 28, 1980 internal Krohne report about the X-1000 states: "[r]ound metal housing also to be employed as a magnetic back connection (as has been conventional for many years already with our large Model 63 and 960 generators). The housing should if at all possible be below the connecting bolts." (CX-59 at 700021).

328. A Krohne article about its ALTOFLUX X-1000 which may have a conduit as high as 4" and which appeared in the Krohne House Publication MSR Technik #10/1982 stated in part:

In order to protect the aluminum oxide spool from external damage, it is shrunk into a steel cast housing whereby the spool and housing are intimately connected.

This process can simultaneously through use of a special material achieve a good electrical contact between the housing and a sintered platinum grounding ring which is on the ceramic body so that the usually required grounding rings are no longer necessary. Subsequently, the coils and magnetic cores are assembled on to the spool.

(RX-153 at 00966; RX-41 at 500369).

329. Krohne advertisement for X-1000 available in diameter up to 4" and DELTAFLUX magnetic flowmeters states in part:

#### CONSTRUCTION OF THE X-1000

The aluminum oxide measuring section is press-fitted into a metal housing. The magnetic coils and interwiring are vibration resistant!

The metal housing gives the best protection against external electrical, magnetic and mechanical interference.

. . .

WHERE AND WHEN THE KHRONE X-1000 CAN BE USED

. Where better than + 1% performance is required

-- The ALTO-MAG is accurate to within + 0.5% of actual measured value!

. When process temperatures are above 300°F  
— Even at fluid temperatures from -76°F to 392°F

. . .

"the economical DELTAFLUX Magnetic is a press-fitted aluminum oxide measuring section for unmatched resistance to corrosive, abrasion, extreme temperatures and sudden pressure changes"

. . .

Another Krohne advertisement that the ALTOFLUX sandwich design can be "fitted between standard flanges."

(RX-41 at 500370, 500366; CX 29 at 2).

330. U.S. Patent No. 3,875,969 which issued April 8, 1975 is titled "Alignment Sleeves For Flangeless Flowmeters and the Like". It is assigned in its face to The Foxboro Company states in part:

. . .

2. Description of the Prior Art

One conventional method for aligning flow devices between flanges requires that the device be mounted in a housing having flanges. The device may be aligned within the housing by using test equipment or matching specially machined surfaces. The housing may then be installed in the line by bolting the flanges together. An example of this general approach is shown in U.S. Pat. No. 2,585,290. One obvious disadvantage of this general approach is the expense of the housing.

. . .

An object of the claimed invention is to provide an alignment sleeve for use with flangeless flowmeters and the like to align said devices during mounting. In the claimed invention a pair of alignment sleeves are provided for placement on two of the flange bolts or studs used to secure the flanges about the flow device. Each of said sleeves preferably comprises a pair of mutually aligned collars, each collar having a central hole and a plurality of faces spaced from the hole axis by distances which vary in a stepped manner so that the sleeve may be rotated to accommodate many combinations of pipe size and line pressure ratings. The flangeless flowmeter consists of a body having an inner passage which matches the inner passage of a pipe. There is no spool placed in the body to form a combined unit.

(RX-173, col. 1, lines 19-28, 35-45, col. 2 lines 44-51).

331. The basic elements of a magnetic flowmeter include a length of straight insulated pipe, a set of electromagnetic coils to produce a magnetic field perpendicular to the flow of liquid through the pipe, and a pair of electrodes located at right angles to both the magnetic field and flow. In use the liquid which passes through the flowmeter becomes the electrical conductor. As it flows through the magnetic lines of force set up by the flowmeter's electromagnets, a voltage is induced in the liquid which is directly proportional to its velocity. The voltage is received by the flowmeter's electrodes for transmission to the applicable receiver instrument. The induced voltage is not affected by temperature, viscosity, turbulence or conductivity so long as the conductivity of the measured liquid is above a minimum threshold level. A typical commercially-available magnetic flowmeter, and known as the short form magnetic flowmeter, is provided with a heavy metal pipe which serves as the body of the meter and is adapted with mounting flanges at both ends. In use, the meter is interposed between the upstream and downstream pipes of a fluid line, each pipe having an end

flange. The mounting flanges on the meter are bolted to the flanges of the line pipes. (Riester CX-1 at 1-2; RX-150 at 481, 482).

332. The flow tube in prior art commercial magnetic flowmeters has been lined with an insulating material through which the liquid to be metered flows. This flow tube is subjected to the same fluid pressure as the line piping and therefore must be of a material and of a thickness sufficient to withstand the pressure, even though the strength of the flow tube is unrelated to its measuring function. (Riester CX-1 at 2).

333. Advantages of the magnetic flowmeter are (a) no obstruction is placed on the pipeline - the pressure loss is no greater than through an equivalent length of straight pipe (b) the signal output is completely linear reproducible to liquid flow rate, (c) since the magnetic meter generates an electric signal directly, no conversion is necessary from hydraulic, mechanical or pneumatic, to electric, for compatibility with computer systems; and (d) metering is unaffected by changes in temperature, viscosity, turbulence and conductivity (above minimum threshold) The model 10D1435A/U Mag-X flowmeter is said to be a compact, volumetric liquid flow rate measurement device which incorporates the original Short Form encapsulated coil design plus an added exclusive electronic principle which is called the Mag-X design. It was said to be the most compact and lightest weight flowmeter available and its size for fluid flow was from 6-8 inches to 48 inches. (CX-40 at B-23, B-24).

334. F&P sells two models of flowmeters manufactured under the '982 patent; these flowmeters are designated by the trade names MINI-MAG and K-MAG. MINI-MAG can handle a vast majority of aqueous solution and slurries, whether viscous, corrosive, dirty or abrasive. It contains a non-magnetic



spool having a molded ETFE fluoropolymer liner which has essentially the same resistance to chemicals as Teflon. Electronically the MINI-MAG operates on plus-minus, pulsed dc coil excitation, meaning that the meters' coils are alternatively energized with positive and negative dc current. In each case, when the magnetic field has stabilized, a voltage measurement is made. The resultant peak-to-peak value of the voltage is a measure of liquid velocity, irrespective of any additional undesired voltage which may be present. F&P offers its MINI-MAG flowmeters with two corrosive resistance electrode holder materials: tantalum or zirconium. The electrodes itself are tungsten carbide. The K-MAG model is essentially the same as the MINI-MAG in its construction and operation. The K-MAG is provided with a ceramic flow spool for those applications for which the fluoropolymer is not suited. F&P offers the K-MAG only with platinum electrodes. (Riester CX-1 at 5, 6).

335. Riester is Senior Vice President of Engineering if F&P and has had that position since 1982. He has a master's degree in electrical engineering. His responsibilities are the management and direction of a group of people who are involved in research and development of process instrumentation products. This group comprises professional engineers, technicians, drafters, model makers. It is a relatively complete R&D environment and its objective is to develop products for F&P that can be manufactured and sold. (Riester Tr. at 92, 93, 101).

336. Herbert A. Riester joined F&P in 1962 as a project engineer and has been with F&P since 1962. (Riester Tr. at 93, 94).

337. Riester has done work on vortex meters, ultrasonic flowmeters, orifice plate meters and variable area meters. The vortex meter includes an

obstruction in the pipeline from which one derives information as does the orifice type flowmeter. (Riester Tr. at 94).

338. Magnetic flowmeters do not have an obstruction and no moving parts. (Riester Tr. at 96).

339. AT F&P Riester has worked on magnetic flowmeters. (Riester Tr. at 97).

340. Riester has been involved in mechanical design considerations of magnetic flowmeters and also has design engineers working for him on magnetic flowmeters. (Riester Tr. at 98).

341. A person of ordinary skill in the art in the 1970s would have had 5-10 years experience in flowmeter design and an undergraduate degree in either mechanical or electrical engineering. (Riester Tr. at 252).

342. A person of ordinary skill in the art, in the mid 1970s, would have been aware of disincentives to design a flangeless electromagnetic flowmeter. For example:

(a) Workers in the art were not aware of any commercial flangeless meter which was capable of withstanding the high compressive sealing forces (Riester Tr at 271, 272); and

(b) Workers in the art believed that in order to have an efficient magnetic return path, complicated laminations of strapping were required. (RX-172; Riester Tr. at 291).

343. In a magnetic flowmeter one creates an electromagnetic field through a coil which is excited with electrical currents and produces a magnetic field. The magnetic lines thread through the annulus (opening or tube in the meter) and as the fluid intercepts the lines of magnetic flux by Faraday's law in the annulus, a voltage is created in the fluid. The voltage is sensed by a pair of electrodes which produce a voltage output that can be

read on a volt meter. The output signal is dependent on the constancy of the flux. To keep the flow conduit uniform between the customer and the measuring section, an opening (annulus) is picked which matches the customer's piping. (Riester Tr. at 106, 107, 108).

344. The ultrasonic flowmeter is devoid of obstructions. It however requires a large electronic package. Also as fluid travels through an annulus, it often is not fully developed and the flow is not symmetrical. Thus two ultrasonic beams has been used but that is more expensive. In contrast a magnetic field threads the entire annulus and so each element of the fluid flow contributes to the signal. (Riester Tr. at 112, 113, 114).

345. F&P's MINI-MAG of a three-inch size is priced in the order of \$2500 to \$3000. An ultrasonic meter would cost about twice as much. (Riester Tr. at 115).

346. Riester's definition of a flangeless magnetic flowmeter is a metering section which is interposed between customer flanges. The word "flangeless" means that the product as being offered does not have what is known as flanges and that such flanges belong to the customers. Thus mating flanges are missing and therefore the unit has to be supported between the customer's flanges. (Riester Tr. at 115, 116).

347. An advantage of a flangeless flowmeter is that it offers the customer the opportunity to interpose the flangeless flowmeter between foreign or alien flanges. (Riester Tr. at 116).

348. The bolts in F&P CPX-21 flangeless three inch flowmeter engage the housing such that when bolts are put through, the metering section is automatically centered because of the clearance between the bolts and the housing. (Riester Tr. at 117).

349. In a magnetic flowmeter to maintain a consistency in the magnetic field, there has to be a return path to obtain a continuous line of flux. The return path is like an impedance or resistance and if the return path is relatively effective then the amount of energy needed to drive the coils is lower and therefore the product has a lower power consumption. The return path is important because it sustains and maintains the magnetic field and in the flangeless meter it acts as a magnetic shield. (Riester Tr. at 122, 123).

350. The housing to be a magnetic return path must be made of magnetic material. Aluminum would not constitute a magnetic return path. Magnetic bolts that encage the housing of CPX-21 have an essentially negligible effect on the magnetic return path because the housing being made of magnetic material performs a shielding function to any stray magnetic fields created by the bolts. (Riester Tr. at 124, 125).

351. Straps of magnetic material can perform a magnetic shielding function but they have to be of sufficient weight either by thickness or length in order to keep the magnetic flux within its confines. A housing, as in F&P's CPX-21, provides more shielding effectiveness than straps because of the fact that the housing is homogeneous and has length. Straps are generally narrow. Moreover if the straps would wiggle there could be a change on the performance of the meter. (Riester Tr. at 129, 130).

352. Taylor Instruments does not manufacture a flangeless magnetic flowmeter. Rosemount does not manufacture a flangeless magnetic flowmeter. Foxboro does not manufacture a flangeless magnetic flowmeter. Brooks, Instrument Division of Emerson Electric Co., does manufacture a flangeless magnetic flowmeter. (Riester Tr. at 237).

353. Brooks' flangeless magnetic flowmeter has an aluminum housing. Aluminum is not a magnetic material. (Riester Tr. at 238).

354. In a small magnetic flowmeter the output signal is smaller than in a big magnetic flowmeter. Thus in large size magnetic flowmeters the coil can be made smaller whereas in a smaller meter the coils are made a little bit bigger to get the same signal. Thus if there is a magnetic flowmeter that is one inch and a magnetic flowmeter that is four inches and there is the same flux, there is four times the signal out in the larger meter. If the same signal is wanted in the smaller meter as in the larger later, there has to be more ampere turns in the coil. In the smallest magnetic flowmeter made by F&P a solenoid coil is used which is not saddle-shaped. The solenoid coil has more height than it has diameter. The larger flowmeter at F&P uses a saddle-shaped coil. (Riester Tr. at 249, 250, 251).

355. The typical academic and practical experience of the average design engineer working in the flowmeter field is five to ten years experience with a bachelor's degree in electrical or mechanical engineering. (Riester Tr. at 251, 252).

356. The first company to offer a flangeless magnetic flowmeter was Fischer & Porter, and this was first marketed in 1982 as the MINI-MAG. The flowmeter started to be developed in 1979. (Riester Tr. at 253, 254).

357. The MINI-MAG is a flowmeter that is described in the '82 patent of the F&P. (Riester Tr. at 253, 254).

358. Ten sizes is offered by F&P in the MINI-MAG version ranging from 1/10 of an inch through 4 inches in diameter. The F&P K-MAG is very similar to the MINI-MAG. It is also available in the same ten sizes in which the spool, through which the medium flows, is changed from Tefsel, which is a plastic material produced by DuPont to a ceramic material. The only difference between the MINI-MAG and the K-MAG is in the spool. There is no

difference in the principle of operation of the K-MAG and the MINI-MAG. They work identically. F&P first offered the K-MAG in 1984. (Riester Tr. at 259, 260).

359. The short form electromagnetic flowmeter in "Instrument Engineer's Handbook" (1969) was manufactured by Fischer & Porter and sold commercially. The meter is a design that is sold in six inch size pipe diameter and larger. It contains mating flanges for customer. The short form meter contains a steel meter body (the housing) but no spool. It has coils and has electrodes. It is not a flangeless magnetic meter. It is not a flowmeter in which the housing and a tube take the compressive forces. In the short form flowmeter if the internal part of the meter, i.e. the potting compound, fails, the coils in the flowmeter are exposed directly to the customer's fluid because there is no intervening spool. In the '82 device there is an intervening spool, which is a barrier to the fluid of the customer and the rest of the "guts" of the meter. The insulating liner in the short form flowmeter was made of different materials and was characterized as both hard rubber and soft rubber. The insulating liner was not designed to absorb any compressive forces and it did not. The flowmeter in the handbook could not be lifted directly. Its steel meter housing was a large, heavy casting and the meters were often supplied with lifting hooks. (Riester Tr. at 262, 263, 265, 265).

360. In 1979 F&P started to develop what was felt to be a flangeless magnetic flow meter. In the early stages one of the more difficult things to solve was to mate the meter within a pair of strange flanges and have it work properly. (Riester Tr. at 266, 267).

361. The German patent 2,040,682 is assigned to F&P in Germany. It discloses a magnetic flowmeter. It is flangeless with a tube of insulating synthetic resin, through which flows the medium, but no external housing. In addition the device has a magnetic flux return path which is embedded in the resinous material and comprised of laminations. The compressive forces for the German meter has to be supported by the mass or glob of potting material. The flowmeter was never commercialized. Its concept was, and is being, investigated in the United States. The reason it was not commercialized is as the meter is subjected to compressive forces it breaks. As one takes the flanges off, the meter is subjected to unknown forces produced by the customer's piping. Not only is there a compressive force problem but there is also a twisting problem. F&P's early experience was that the tube cracked. It is very difficult to have such a structure take compressive forces as exerted by the customer's flanges and there is no housing and hence as bolts are put through such a design the bolts have a much greater effect on this design than F&P's MINI-MAG. The bolts change the meter's calibration so that when a meter is shipped to a customer and the customer uses stainless steel bolts or switches to steel bolts the customer may have magnetic properties of these bolts interfere with the magnetic properties of the meter. In such meters there is the axial forces and also internal forces which as the fluid goes through the pipe the metered section has to withstand the internal pressure of the fluid. If the structure is not strong enough the meter can crack because of the internal forces. There are also bending forces which come from situations where the customer's flanges are not aligned. This means that the adjacent flanges are not parallel at 90 degrees with the metering section so when the bolts are started to be tightened, there will be a

twisting action and as a result the metering section is going to be subjected to a twisting force that will also tend to break the metering section. (Riester Tr. at 270, 271, 272, 273, 274, 276, 277, 278).

362. As head of R&D in the United States Riester had periodic communications with F&P's German facility. (Riester Tr. at 275).

363. In Figure 1 of the British Sybron patent 1,424,875 the metering section has no compressive forces. The meter is just hung by a support beam. It is like opening a manhole and the meter is dropped inside the manhold. There is no extra force on the outside of the meter vis a vis the inside of the meter. The flowmeter is not between flanges. Coils and electrodes are located in such a way that they do produce a magnetic field and are essentially sealed with a cover so water does not get into the flowmeter. Straps are used to produce the magnetic field. (Riester Tr. at 284, 285, 286).

364. The British Sybron patent discloses that the cover is made of stainless steel and stainless steel does not support magnetic lines. That is why there are straps and coils to produce a magnetic structure. (Riester Tr. 289, 290).

365. According to Mr. Riester, the cover in the British Sybron patent is on the inside of the ceramic flanges located between two grooves and not in a position to support any load. The cover is a thin protective cover to keep water out of the spool. (Riester Tr. at 291, 292, 293).

366. It is Mr. Riester's opinion that if the cover of the British Sybron patent was in intimate contact and intersected the flanges on the inside, the cover would help in the compressive forces but would not help with any twisting forces, because of the size of the cover. The British Sybron patent according to Mr. Riester does not show a housing. A housing is a structural member, it has strength and it has cross-section. (Riester Tr. at 295, 325).



367. Figure 3 of the British Sybron patent show a flow tube. Figure 7 shows a bird cage type of enclosure for the flow tube. (Riester Tr. at 323, 324).

368. In the '982 patent the housing covers the spool completely. The '982 patent states "surrounding the spool and concentric therewith." (col. 3, lines 54). Also in Figures 2 and 3 there are four diagonal lines at 10A, 10B which shows the housing covers the spool completely. Description at col. 2, lines 40-44 is further support. (Riester Tr. at 347, 348).

369. In the British Sybron patent according to Riester the spool is not coaxially disposed within the cover. The cover is shorter than the spool. (Riester Tr. at 332, 347).

370. A seam weld is a weld which is used to join two metal parts. The phrase "seam welded or otherwise joined" is at col. 4, lines 53-54 of the '982 patent. (Riester Tr. at 369, 370).

371. When the British Sybron flowmeter is interposed between the pipe flanges which comprise the spool between the flanges, Riester is of the opinion that an engineer of ordinary skill or average skill could attempt to strengthen the spool itself. However as the spool is strengthened, the cavity that is available for the coils becomes smaller and smaller. It is a difficult question to answer how much an engineer have to thicken the walls of the spool, for example, because of the uncertainly of the internal pressure requirements and the length of the ceramic spool. The longer the length of the spool the more difficult is the problem because with longer length there is more tendency for the mating flanges to be out of line. In addition the spool material of the British Sybron patent is made out of porcelain. Porcelain is normally a material that cracks easily although Riester is unable

to compare directly the specific compressive strengths of porcelain and steel. (Riester Tr. at 378, 379, 380, 381).

372. The terminology "saddle coils" takes on other aspects considering the flattened out appearance. They can be triangular, round or square. It is appropriate to refer to the coils of Fig. 5.8(c) in the Handbook at page 581 as being saddle-shaped. The Fig. 5.8(c) flowmeter used the housing as the magnetic flux return path. The flowmeter is flanged in Figure 5.8(c). Bolts connect the flange of the metering section with the customer's flanges in Figure 5.8(c). Until last year the flowmeter was offered in six inch pipe size. (Riester Tr. 386, 387, 388, 390; RX-150 at 481).

373. Riester is of the opinion that the outside diameter of the housing most of the time lies outside of the bolt holes in the Figure 5.8(c) flowmeter. (Riester Tr. at 392; RX-150 at 481, 482).

374. The meters illustrated by CPX-22 and those by CX-40 at B-24 were at one time offered simultaneously by F&P as part of its product line. (Riester Tr. at 404, 405).

375. A F&P memo dated June 29, 1982 makes reference to a Krohne house publication describing the Krohne ALTOFLUX X-1000 flowmeter. Copy was received by Mr. Riester. Riester thought the Krohne description was a "knock-off" of F&P's product line. He discussed the matter primarily with counsel. (RX-183; Riester Tr. at 414, 415, 422).

376. RX-162 is a F&P invention disclosure. Page 2 is signed by R. L. Crumley and is dated October 31, 1978. Page 1 under - - "Name of Invention" states - - Diamond Shaped Coils for Mini-Mag - - . Also under "Name, address and citizenship of inventor(s): - - "Richard L. Crumley, Southampton, Pa." is crossed out and and what appears to be "Sk." and "CIP" written in. As to

"Object or Purpose of Invention" it is said that the "object of this idea is to package the magnet coils for the MINI-MAG design so they fit into the space outside the fluid conduct and inside a magnetic return path located inside the bolt circle of a standard flange. "The "First conception of invention date" is said to be - - Sketches for Model Shop 8 June 1978 - -. Under "Name of Invention: it is stated: - - Diamond Shaped Coils for Mini-Mag - - .

When the MINI-MAG design according to Roy Schmoock's proposal of 21 July 1976 [sic] was modeled in a 4 " pipe size, much efforts was expended to obtain a proper flux distribution for optimum flow measurement. While much of this effort concerned various shaped pole pieces, it was found that coils similar to those used in the 10D1430/35 design (without pole pieces) could be used advantageously. Since the coils themselves are shaped to produce the proper flux distribution, an iron core is not required. An added benefit to this design is that the coils can fit inside a magnetic return path which can be contained within a standard flange bolt circle and thus be more compact. At this time it appears this design is feasible for designs larger than 1 " pipe size but not for sizes smaller than 1" pipe size.

Mr. Riester does not know who struck out Crumley's name and inserted the name of Schmoock. (RX-162, RX-162a; Riester Tr. at 430).

377. A Roy Schmoock invention disclosure of July 12, 1976 is to a "Magnetic Flowmeter," which states in part:

An effort to reduce size and cost of the existing magmeters. Patentable feature is that the injection mold forming the liner and holding the electronics in conjunction with the outer magnetic return path form the structure that holds the coils and electrode leads and finally forms the potting mold. The outer magnetic return ring also reinforces the pressure vessel.

It is said that an object or purpose of the invention was "Cost savings." First conception of invention date is "1975."

378. A Roy Schmoock invention disclosure dated July 12, 1979 is for "Unitary Electromagnetic Flowmeter". It states that it is a continuance of unitary electromagnetic flowmeter patent 4,098,118 and an improvement and addition to original patent. First conception of invention date is April 20, 1975. First record of invention date is May 1, 1979. It also state in part:

This first is the use of a lined metal spool which will serve as the flow conduit as well as the pressure containing vessel. This lined metal spool will also serve to withstand the compressive forces resulting from the bolt torque used to seal the meter between adjacent flanges (this option has already been covered). Surrounding this spool and the magnet elements (coils and cores) is a metal housing whose purpose it is to provide:

- a) the magnetic return path for the flux,
- b) the mechanical support for the converter assembly,
- c) the means for locating the various sub-assemblies; spool, leads, magnet parts, etc., and
- d) provide a weatherproof enclosure for the meter and provide an integral mold for potting the space between the spool and housing if one so desires.

(Again, the metal housing has been previously covered but not in combination with the lined metal spool.)

An outgrowth of this design is a split outer metal housing which will provide all the functions mentioned above, but which will also greatly simplify the assembly of the various parts which constitute this meter. The two halves of the housing can be joined by screws or by welding. With this design it is also possible to cast the magnetic cores integral with the housing.

The invention disclosure was included with a Ser. No. 75,037 ('340 patent). (Krohne deposition exh., K-4 at 03113, 03114, 03115).

379. Only the flowmeters of Fischer and Porter of two inches and above are manufactured in accordance with the '982 patent. (Riester Tr. at 434).

380. According to Mr. Riester, "joined" means to fasten together and the resultant configuration looks like one piece. Mating has sort of the same connotation. Where parts are mated they essentially become one piece. Welding, brazing and heat shrinking are a form of joining. In the MINI-MAG the joint between the tube flanges and the housing is welded. In the K MAG one of the joints is welded and the other joint is press-fit into a ring which is subsequently welded to the housing. (Riester Tr. at 460,461).

381. The ALTOFLUX was first sold in the United States on August 24, 1982. The DELTAFLUX was first sold in the United States on November 24, 1982. Krohne publicly introduced its magnetic flowmeters with ceramic flow tubes in June 1982 at the Achema trade show in Frankfurt, Federal Republic of Germany, under the designation "X-1000." (high accuracy model) and "DELTAFLUX" (lower accuracy). (Beahm RX-1 at 15; Hofmann RX-11 at 9, Tr. at 1661).

382. Both the ALTOFLUX and DELTAFLUX flowmeters utilize an aluminum oxide ceramic liner with sintered platinum electrodes. A "liner" material is not used. Krohne's meter utilizes a flow tube made completely of 99.7 percent pure aluminum oxide which is cast and then co-fired with integrally minuted platinum electrodes to form a very hard, abrasion and corrosion resistant flow tube. The platinum electrodes do not depend on spring loading and plastic materials for sealing purposes. The electrodes are permanently sintered into the wall of the aluminum oxide, forming an exceedingly secure and permanent seal. This construction is said to be covered by Krohne America U. S. Patent

4,507,975 and to be the basis of a Krohne America U.S. District Court suit alleging that Fischer and Porter's K-MAG infringes said patent. It is said that next to Krohne's aluminum oxide flow tube and platinum electrodes, the most important distinguishing feature of the Krohne's flowmeters is the very high accuracy rating, 1/2 percent, of Krohne's premier model, the X-1000 magnetic flowmeter. (Beahm RX-1 at 15, 16, 17, 20).

383. Friedrich Hofmann received his degree in Electrical Engineering in 1968 from the Technische Hochschule, Darmstadt, Federal Republic of Germany. He began employment with Krohne Messtechnik GmbH in 1973 as Head of the Electrical Development Group which is responsible for developing the signal converters for Krohne's flowmeters. He is presently product manager for Krohne magmeter flowmeter and is responsible for design specification for service, repair, application and technical support. (Hofmann RX-11 at 1; Hofmann Tr. at 1661).

384. Mr. Hofmann testified that in the Krohne flowmeters of diameters two inches and above, in issue in the investigation, the housing does not serve as a magnetic return path and that what so serves is a magnetic, ferromagnetic strap wrapped around the spool piece and the coils of the flowmeter. Mr. Hofmann testified that more than 97 percent of the total flux passes through the straps. The straps are shown as 8 in Fig. 1 of Mr. Liptak's witness statement. (Hofmann Tr. at 1662, 1663, 1669; Liptak CX-3).

385. Mr. Hofmann testified that the housing of the Krohne flowmeter is made of cast or malleable iron and the magnetic properties of this material is quite poor. The relative permeability of the material is said to be approximately 200 to 400 while the transformer iron or the magnetic strap iron used for the return path is said actually to have a relative permeability of

8,000. The housing is said to take over only very insignificant parts of the compressive forces coming from the flanges to the spool piece. It is said that the actual order of magnitude of these forces taken over by the housing is 8 to 10 percent of the total compressive forces put onto the flanges of the spool piece. Mr. Hofmann testified that if the housing would take over more than 25 percent of the compressive forces coming from the flanges to the spool of the pipe or to the spool of the unit then this housing would be at the end of the normal design limits of the cast iron. Mr. Hofmann testified that the Krohne housing never broke due to compressive forces. When asked whether Krohne conducted any tests to determine where or at what load the housing would fail under compressive forces, Mr. Hofmann testified no because actually the housing had not been designed to take compressive forces and the design of the flowmeter is such that it is only insignificantly loaded by those forces. (Hofmann Tr. at 1669, 1670, 1671, 1672).

386. Cast iron housing was selected because cast iron is inexpensive, easy to cast, and easy to machine. Hence mostly economical reasons influenced the selection of cast iron as the housing. (Hofmann Tr. at 1674).

387. Mr. Hofmann testified that the housing was not chosen by Krohne with any consideration for bearing compressive loads and that cast iron has a quite low tensile strength and is not a very strong or elastic material. He did not rely on any documentary evidence, including test data, for this conclusion. He also testified that a design whereby the housing would take significant compressive loads would mean that the design would be temperature dependent and hence any such design would not be fixed. (Hofmann Tr. at 1674, 1675).

388. Mr. Hofmann testified that Krohne during the development of the flowmeter did very extensive testing of the spool pieces and also gave an order to an independent authority in Germany, the TUV, which is responsible

for testing all pressurized vessels for the ability to bear pressure and forces which stress a vessel. This authority was said to have tested in early 1983 all sizes of spool pieces from one-tenth of an inch to four-inch with regard to compressive forces, with regard to pressure bearing capabilities, with regard to combined stresses as compressive forces plus pressure plus bending moments and so on. It was said that the result of this testing was that Krohne has very high safety factors in the spool pieces; that as a result of those tests Krohne made a determination that its spool was sufficiently well designed to withstand the entire compressive forces that it would be subjected to. (Hofmann Tr. at 1676, 1677, 1678, 1679).

389. Mr. Hofmann testified that "[w]e did some tests at Krohne" with regard to having a proper fluid seal between flanges and spool pieces with difference types of gaskets and hence different torques had to be applied and some tests were done "regarding safety margins if those torques are exceeded." (Hofmann Tr. at 1688).

390. Mr. Hofmann testified that the design of the spool piece was made under the assumption that 100 percent of the compressive force and 100 percent of the pressure forces coming from the liquid were taken over by the spool piece. (Hofmann Tr. at 1689).

391. Mr. Hofmann testified that where the housing is exposed to acid in a chemical plant, acid may destroy the housing and if the housing really takes over a high percentage of the forces which are put on the spool then the spool will break as soon as the housing is destroyed. He also testified that load transfer or load sharing between spool and housing is dependent on the temperature of both or on the temperature gradient between both and that this is due to the shrink fit coupling between both; that there is not a fixed variable of transfer or load sharing between both; and that the spool piece



was designed to take over 100 percent of all forces put on the flowmeter. The load transferred from the spool to the housing was said to be very dependent on the temperature of the spool and of the housing, and this was said to mean that the ambient temperature is influencing it, the fluid temperature may influence it and even dynamic changes in fluid temperature will influence it. (Hofmann Tr. at 1689, 1690).

392. Mr. Hofmann stated that he is able to calculate the amount of forces that may be transferred between the spool and the housing in the Krohne meters and this data is the friction force between housing and spool piece; that the friction force is determined by applying a force to the spool piece, measuring said force and increasing said force until the spool piece is moving out of the housing. Mr. Hofmann testified that he did the calculations "yesterday" to reconfirm the data which "I remembered about." He calculated the typical compressive load value on the housing is less than 10 percent of the total compressive load. No documentary evidence was presented regarding the data Mr. Hofmann remembered. (Hofmann Tr. at 1692, 1693, 1694, 1695, 1696; RPX-26).

393. Mr. Hofmann testified that even assuming 25 percent of the total compressive load is transferred to the housing, one would not be able to reduce the wall thickness of the spool in any significant amount. (Hofmann Tr. 1696).

394. It is Mr. Hofmann's opinion that the prior art CPX-22 flowmeter was designed to meet AC drive requirements and does not represent size and weight relations as they are shown at newer DC field magnetic flowmeters of Fisher & Porter. (Hofmann Tr. at 1724).

395. In the Krohne development of small sized magnetic flowmeters of size one inch or less, the introduction of the DC field technique in 1974

reduced, or has been utilized, to reduce small-sized magnetic flowmeters from a weight of 45 pounds down to approximately seven pounds. (RX-175; Hofmann Tr. at 1725).

396. The TUV report was prepared by TUV, a privately owned organization in Germany. It contains no test data developed by Krohne. Krohne developed test data with regard to the force required to move the spool from the housing and this has been done quite frequently. When asked if there are reports at Krohne which indicate the amount of force required to move the spool from the housing, Mr. Hofmann testified: "They have been done by these procedures, but if there is everything all right maybe one takes a note but that doesn't make a report." Mr. Hofmann also testified that "I think data are available, but I'm not sure about documents." He testified that the data is not necessarily on a piece of paper; that he thinks that "part of the data are in the brain or the memory of the people who are handling those things quite often, with whom we check, is everything all right against data which they know from experience which are all right." Mr. Hofmann testified that the tests were done quite frequently at Krohne but it is a kind "not of production testing, just a test making sure that tolerances and dimensions are all right. And if it is not all right, we don't document it every time.". The testimony was also:

Q. Is this part of quality control at Krohne?

A. It is a kind of production and development testing and testing, which sometimes has been done in conjunction with redesigns or selecting different materials or changing the supply of housing or other things.

Q. Have you looked for any test data that was developed at Krohne?

A. I did not need to see, for I am involved in that by my position by the way I have to work with people to cooperate. And so I got some data, which again are anywhere in my brain.

Q. So you got all this data from you own brain?

A. Not all. For example, friction coefficients, the total range of friction coefficients between ceramics and housing is stated anywhere in books.

Q. Let me be sure I understand your testimony. Is your testimony that at Krohne there is no paper, no document, which contains test data relating to the force required to move the spool in the housing?

. . . . .

The witness: (Directly)

I have to say I don't know whether there are documents or not. I have been informed last week on Wednesday that I have to, Wednesday night, that I have to participate here, and, I did not have any time to check which documentation is available for that.

The TUV report subjected the X-1000 and DEF 200 flowmeters to the following tests:

1. preliminary examination of drawings for consistency;
2. thermal shock tests at increasing and decreasing temperatures followed by tests for surface cracking;
3. bursting tests with water as the pressure medium;
4. creep tests with water as pressure medium; and
5. bursting tests with inside pressure and bending stresses.

There is nothing in the TUV report, nor in a research report containing a date of January 15, 1982 (Exh. 29) nor; survey report (Exh. 28), that shows that the Krohne housing does not share the compressive load exerted upon the Krohne meter or that the Krohne spool is capable of supporting all the compressive forces exerted upon it by the end flanges of a pipe. (Hofmann Tr. at 1727, 1728, 1729, 1730, 1731; Stevens CPX-10, Exh. 28, Exh. 29, Exh. 30).

397. When asked if in his testing of forces required a removal of the tube or the spool from the housing, Mr. Hofmann conducted any tests to determine how much more or less force would be required under different

temperature conditions, he testified that he did not think that these tests actually have been done because "we did extensive testing regarding fluid temperature and ambient temperature on the whole unit during development. And it never showed up that the housing actually has gone loose or actually has compressed so much that the ceramic could not bear the load from the flanges. And so we had no reason to do detailed testing with that respect." (Hofmann Tr. at 1732).

398. The testimony was:

Q. So that during the development of the flowmeter, this magnetic flowmeter that is involved here, you did conduct tests of the meter in which the fluid that was passing through the flowmeter was at different temperatures?

A. Yes, we did.

Q. And did you record that data?

A. These data are recorded.

Q. It is recorded, is that your answer? It is recorded?

A. What we recorded have been several influences of the temperature of the fluid on the accuracy of the whole unit.

A. The temperature of the fluid?

A. Yes.

...

Q. And did you check to see that the housing was tightly secured to the spool or, conversely, the spool was tightly enclosed by the housing during these different temperature tests?

A. We did not find that it has gone loose, neither in development nor in practical applications. And these are applications up to fluid temperatures exceeding 200 degrees Centigrade, and the housing of the meter body fully thermally insulated within the pipe installations.

Q. So that the spool was always tightly held by the housing, even under those extreme temperatures that you just mentioned is that correct, sir?

A. We did not test how hard the spool or the housing was gripping on the spool, but it never happened under practical conditions that it has gone loose, turned over, or gone apart, as you told yesterday or has been discussed yesterday.

Q. Now, have you tested the ceramic spool to see whether it physically gets shorter when subjected to compressive loads on the opposite faces?

A. Yes.

Q. Did you record that test data?

A. I remember just somebody telling me a value regarding this three inch, and I'm not sure if this has been written down.

Q. So do you remember a value for the three inch spool?

A. Yes.

Q. And when you say three inch spool, you mean the type which is before you in CPX-23?

A. Yes.

Q. The inside diameter is three inches?

A. Yes.

. . .

Q. Now, I'm asking whether at Krohne in Germany you subjected the spool to a compressive force by applying such force to the opposite faces, and did you measure the shortening of the length relative to the different compressive forces?

A. We have done those measurements, especially on the larger sizes here.

. . .

A. Okay, the three inch size here. CPX-23. And the value I remember is applying a force of approximately 800 kilonewton.

. . .

This reduced the total length of the ceramic body approximately one micrometer.

Q. Now, one micrometer is one millionth of a meter?

A. Yes.

Q. And do you know the conversion factor between a kilonewton and pounds, pounds per square inch?

A. . . . So it should be 220 pounds, approximately.

. . .

Q. So that is about 176,000 pounds?

A. Yes.

Q. If my arithmetic is correct, it comes out to about 176,000 pounds. And 176,000 pounds applied to a three inch ceramic spool caused a reduction in total length of about one millionth of a meter?

A. One millionth of a meter, that's the value I remember, yes.

(Hofmann Tr. at 1732, 1733, 1734, 1736, 1738, 1739).

399. Mr. Hofmann is of the opinion if ten pounds of force was applied to the spool it would cause some shortening. However it would be so insignificant as to be almost unmeasurable. (Hofmann Tr. at 1740).

400. Mr. Hofmann would expect the diameter of a flange to be increased as a result of a compressive force being applied to the opposite faces of the spool but very insignificantly, less than one micrometer. (Hofmann Tr. at 1741).

401. Mr. Hofmann testified about a test at Krohne in which a force is applied to the spool, the force required to move the spool relative to the housing was between 10,000 and 15,000 pounds. Mr. Hofmann did not perform the test personally. It was not performed within his viewing nor in his

presence. Mr. Hofmann testified that in the test the housing is put on a metal ring which has an inner diameter slightly larger than the inner diameter of the housing so that the spool can move freely through the ring. Mr. Hofmann testified that the pipe flanges applied a compressive force against the spool flange of about 62,000 pounds, and that he concluded that because the amount of force required to move the spool relative to the housing was about or less than 12 percent of the total compressive force, only 12 percent of the compressive force was shared by the housing. In the test Mr. Hofmann did not have any flange or member restraining the movement of the spool. The spool was simply pushed relative to the housing. (Hofmann Tr. at 1747, 1748, 1749, 1750).

402. Mr. Hofmann testified that Krohne tested the spool pieces up to 170,000 pounds and the housing of the flowmeter has never been damaged and hence the housing takes over less than 15 percent of the load. He also testified that in his opinion the housing was not sharing a substantial part of the load because in his experience the ceramic tube has broken but the housing has not broken. (Hofmann Tr. at 1758, 1759).

403. Krohne's housing is an inexpensive standard cast iron. (Hofmann Tr. at 1760).

404. The evening before testifying Mr. Hofmann asked Altometer, a Krohne subsidiary who is producing the primary heads, to confirm data that the magnetic return path of the Krohne Housing was poor relative to the Krohne magnetic strap. The results were reported to the witness the morning of his testimony. No documentary evidence showing such data was produced. (Hofmann Tr. at 1761).

405. Mr. Hofmann testified that he knows one value for the tensile strength or compression strength of the iron in the housing and if one takes

the load that is coming from the flanges and simply assumes that 50 percent of the load is transferred to the housing and the cross-section of the housing is taken, that by using a compression calculation or a calculation of the tension in the material, then the compression or tensile strength of the housing is exceeded by a factor of two. Mr. Hofmann however doesn't know the percentage of carbon in the iron of the housing but stated it is a normal cast iron with a high content of carbon. Mr. Hofmann does not know where Krohne obtains the housings for its flowmeters. At Krohne there should be a drawing that specifies the type of material for the housing but Mr. Hofmann does not know what that is. (Hofmann Tr. at 1764, 1765).

406. Mr. Hofmann testified:

Q. Now, if you don't know the composition of the iron, then how can you determine its tensile strength?

A. I have asked the man who is responsible for that kind of housing, for the construction of that housing, for the tensile strength of the iron which is used for that housing. I did not ask him for the type, for the name or type designation. I just asked him for the tensile strength.

Q. Is it based on the information he gave you that you have concluded that the iron is not as strong as the ceramic material in the tube?

A. There are two facts that it is based on. The one fact actually is the tensile strength value. The other fact or is a point which I mentioned earlier that we had breakage of the ceramic tube but never of that housing.

Q. Why couldn't that be because the housing is stronger than the tube?

A. If I look at the compression data or the tensile strength data of any cast iron or most cast iron, especially those which are inexpensive, these data are very small in comparison to the compression strength of ceramic.

. . .



Q. The percentage of carbon determines the characteristics of the iron, does it not, sir?

A. It does.

Q. And because you don't know the percentage of the carbon you don't know the characteristics of this iron used in the Krohne housing, do you?

A. I did not expect to be examined here in let's say the delivery data of some components. I have expected to be examined here with regard to the magnetic field return path and with some of these questions with regard to the load sharing, but I did not have the feeling that I have to ask for specific material before I left, and I am sorry, I did not have the time for that, and I just asked for the data which are -- have been most important in my personal view, and one of them has been the tensile strength of that iron, but not the type designation or what else. I am sorry about that.

(Hofmann Tr. at 1765, 1766, 1767, 1768).

407. The Krohne housing is shrunk fit over the spool so it holds the spool with 30,000 pounds of force. If the housing is stronger in tension than the ceramic material of the spool, one would expect the spool to fail before the housing fails. In practice Krohne has found that the spool has failed but the housing has never failed. (Hofmann Tr. at 1769).

408. A Krohne Instruction Manual for X-1000 Flowmeter states at 9 that "It is absolutely essential that the pipe flanges be plane-parallel in the tightened down state." That means that the ceramic is vulnerable to cracking or breakage. Mr. Hofmann testified that this warning is in his opinion in an older edition of a manual; that the newer manual indicates that the nonparallelism may not exceed .5 millimeters. (CX-94 at 9; Hofmann Tr. at 1769, 1770).

409. Mr. Hofmann testified:

Q. Now, you testified, Mr. Hofmann, that the relative permeability of the iron housing has a certain Mu number.

A. Yes.

Q. And the Greek letter Mu is the designation for permeability?

A. Yes.

Q. But you got that from somebody else in your company. Is that correct?

A. Yes.

Q. And from where did you get the permeability value for the magnetic strap used in the Krohne meter, CPX-23?

A. From the same person in our company.

Q. Do you know the material? Do you know of your own knowledge the material of the strap, the magnetic strap used in the Krohne meter? That is CPX-23A.

A. I don't know exactly. I only asked for the relative permeability.

Q. So that your testimony with regard to which - - with regard to whether the magnetic flow path was primarily through the housing or primarily through the strap relied on the information given to you by this person at Krohne?

A. Yes, that is right.

(Hofmann Tr. at 1771, 1772).

410. There are different kinds of cast iron in the housing of Krohne CPX-24 as compared to Krohne CPX-23. Mr. Hofmann knows that the iron of CPX-24 has been selected according to its magnetic properties. He knows it from the fact that the sales department requested several times for a different material for some reason and that Altometer, who does the design of the magnetic parts and the construction or the design of the meters refused because this material has been specially selected according to the magnetic properties. The magnetic return path in Krohne CPX-24 is established by the housing. (Hofmann Tr. at 1773, 1774).

411. In the Krohne CPX-24 flowmeter a large part or nearly the total coils are extruding outside of the bolt circle and the magnetic return path is beginning at the top of the coils. All of the flux lines emerging from the coil and passing back to the other coil are passing through the circular portion of the housing in CPX-24. The magnetic field lines are passing through sections inside the circle of bolt holes and also sections outside the circle of bolt holes. Every flux line travels within the circle and also travels outside the circle. (Hofmann Tr. at 1774, 1775, 1780, 1781, 1815, 1816, 1817).

412. Mr. Roskam is the manager of Altometer, or managing director of Altometer. Altometer is a 100 percent company owned by Krohne. Altometer manufactures the primary heads of the magnetic flowmeters. (Hofmann Tr. at 1780, 1781).

413. When Mr. Hofmann was asked whether he was aware of tests performed by Mr. Roskam or anyone else in his group on the effect of applying bending forces to the ceramic tube, Mr. Hofmann testified: "I again want to refer to the TUEV report I mentioned. There have been done bending tests on small diameter ceramic pipes, and the smaller diameters have been selected especially because they are most relative to bending forces applied to the flange end of the spool." (Hofmann Tr. at 1785).

414. Size of a magnetic flowmeter can have an absolute bearing on its selection in at least certain applications. The size of the mag head itself can afford the ability to mount a flowmeter closer to a wall. Size can be of importance. (Igoe Tr. at 826; Foster Tr. at 876, 888; Williams Tr. at 929; Whittington Tr. 949, 954, 959).

415. Mr. Hofmann called Mr. Roskam the evening before Mr. Hofmann testified and asked him to tell his people to conduct two tests on a three inch meter to make sure or to confirm the data that Hofmann has represented is not only the theoretical data but practically supported. (Hofmann Tr. at 1788, 1789).

416. A Krohne internal report dated November 28, 1980 for "Draft of list of responsibilities X-1000" states: "Round metal housing also to be employed as a magnetic back connection (as has been conventional for many years already with our large Model 63 and 960 generators). The housing should if at all possible be below the connecting bolts." (CX-59 at 1).

417. Design of the X-1000 has been done at Altometer in combination with a special construction group. When development of the X-1000 was going on at Krohne, Mr. Hofmann was in the development department for electronics. (Hofmann Tr. at 1792, 1793).

418. Krohne in the evolution of magnetic flowmeters - 2 inch size in 1970 introduced a Teflon-lined flowmeter (MID51C). Its dimensions were 13.8" long by 9.1 " wide by 15.4 " high. It weighed 77 pounds and its electronics was AC. In 1979 Krohne introduced a flowmeter (M950) that was 7.9" long, 7.2 inches wide and 9.3 inches high. Its weight was 29 pounds and it used DC electronics. In 1982 Krohne introduced the X1000 that was 4.1" long by 4.0" wide by 8.6" high. It weighed 9 pounds and used DC electronics. (RX-107).

419. Krohne introduced its first commercial magnetic flowmeter in 1965. In 1975-76 Krohne designed and manufactured a test wafer-type (flangeless) flowmeter for Thyssen Steel Works at Duisburg, Federal Republic of Germany. Due to the restricted space requirements, the meter was initially installed

was the wafer-type. Because of customer concern with possible corrosion in the bolts extending through the meter body, it was redesigned to incorporate flanged end through which the bolts passed outside the meter body. The flanged version was the subject of a utility model application in Germany, German patent App. G 7619769,8. (Hofmann RX-11 at 6, 17; CX 101).

420. DC drive enhances the measuring capabilities of the magnetic flowmeter and also diminishes its bulk. The latter result is a consequence of the diminished field strength required by DC drive systems. (Hofmann RX-11 at 4).

421. Part of Krohne's developmental effort was in the direction of reducing size and weight. In the 1979 version (M950) the housing is made of magnetic material. In the 1970 version (MIC51C) the housing was made of aluminum. The 1979 version was flanged but the tube was not ceramic. The tube was of stainless steel with a lining. The term "primary" means a meter and the term "secondary" means electronics. From 1979 to 1982 there were no other development of primaries at Krohne other than what is shown in RX-107. The 1982 flowmeter is flangeless and there is a reduction in weight of about one-third. Mr. Hofmann testified that the width of the 1982 flowmeter had been reduced due to a different coil construction. (Hofmann Tr. at 1798, 1799, 1800; RX-107).

422. The utility model application G 7619769,8 filed by Krohne in the German patent office on June 22, 1976 was to an arrangement of coils in a flowmeter operating in accordance with the induction method. Flanges on the meter made it possible to connect the meter to an existing pipeline. The meter did not include a ferromagnetic housing. There was a ferromagnetic

enclosure (strap) for the field coils. Magnetic straps were used for the return path. The claim of the application read:

Claim

Arrangement of coils in a flowmeter operating in accordance with the induction method and consisting of a test pipe that is supplied with connection flanges, of at least two saddle coils positioned symmetrically around the test pipe, and of two electrodes positioned at the inside of the wall of the pipe in the center of the saddle coils with their axis extending perpendicular to the lines of the field, characterized in that each coil is mounted on a strip of iron that rests against the test pipe in the form of a bow in the section that extends parallel to the axis of the pipe and in that both saddle coils are surrounded by a section of iron pipe that is more or less equal in width, whereby the rest of the space between the interior iron core and the outer iron jacket inside the saddle coils is completely occupied by an iron component approximately as thick as the coil.

The three or four flowmeters made according to the utility model application were potted with a polyurethane material. (Hofmann Tr. at 1804, 1805, 1806; CX-101).

423. Mr. Hofmann testified that Krohne did not do detailed tests on the housing during operation to determine how much of that housing in Krohne's CPX-23 allows for the flow of magnetic flux lines because the housing is not used for the magnetic return path. It was testified that the magnetic return path is the strap which is wrapped around the coils or which keep the coils in place. (Hofmann Tr. at 1808).

424. Mr. Roskam has a degree in electric technology and measurement and control techniques. After receiving the degree in about 1959 he first worked for a firm named Alto that was the predecessor of Altometer. He worked there for about two years as a service technician. In 1962 he returned to Altometer

(Alto) which at that time was brought up by Krohne. He has been employed by Altometer since 1962. As managing director of Altometer he is responsible for the production of Krohne's electromagnetic flowmeters. Altometer manufactures only the primary portions of the electromagnetic flowmeters i.e. that portion of the flowmeter which is physically positioned in the flow line as opposed to the electronic portion of the flowmeter. (Roskam CPX-5 at 3, 4, 5).

425. Altometer has about 150 employees of which around 100 are full time employees who report directly to Mr. Roskam's staff in Sliedrecht, Federal Republic of Germany. Four persons in Mr. Roskam's staff report directly to Mr. Roskam i.e. for administration Mr. Vonk; for production Mr. Van Andel; for engineering and quality Mr. Baars; and for development Mr. Ijmer. (Roskam CPX-5 at 6).

426. Altometer has been manufacturing small electromagnetic flowmeters which contained ceramic liners or little pipes for a long time. Electrodes in those meters passed through the walls of the ceramic tube. There was a layer between the electrodes and the ceramic tube of Teflon which was introduced with spring pressure. A hole is made in the ceramics and a ring of Teflon put in and then the electrodes is inserted to keep the electrodes compressed. Stainless steel or platinum was used as the material for the electrode. (Roskam CPX-5 at 7, 8, 9, 10).

427. Figure 2, reference No. 3 of utility model application G 7 619 769.8 filed in the German patent office on June 22, 1976 represents the flangeless electromagnetic flowmeter made by Krohne around 1975 for a customer. (Roskam CPX-5 at 12, 13 14).

428. Mr. Roskam was in charge of the development of the primary portion of the meter on the Krohne X-1000 project. (Roskam CPX-5 at 23).

429. Mr. Tromp was assigned to the X-1000 project to buildup the housing and the connection of the housing with the ceramic. A Mr. Stevens made theoretical calculations and drawings directed to the primary. (Roskam CPX-5 at 26, 27).

430. Mr. Roskam testified that metals can be used for pressure and tensile force and that one can apply pressure on ceramics only. Forces comprise both tensile and pressure forces. When ceramic was considered as a liner in the X-1000 project, bending forces were more of a concern than compressive forces. (Roskam CPX-5 at 32, 33).

431. For the manufacturing of the X-1000 or Delta Flux flowmeter, electrodes are built into the ceramic, the house is heated, and as a result the house gets a larger diameter. The heated house is placed over the ceramic tube and it then cools down and thereby it is fixed. (Roskam CPX-5 at 73).

432. Altometer purchases the housings for the X-1000 and Delta Flux products. Housings are turned out with very tight tolerances at Krohne. (Roskam CPX-5 at 74, 75).

433. Mr. Roskam in deposition testified:

Q. Mr. Roskam, what function does the housing in the X-1000 and Delta Flux perform?

A. Protection against the environment, partial conduction of the magnetic field. I can't think of anything else - - and it contains a connection box.

Q. Does it lend physical support to the ceramic core?

A. Yes.

Q. Does it lend physical support to the core with respect to the compressive forces which are exerted on the core during use?

A. I don't know what you refer to when you are mentioning the word "core."



Q. The ceramic liner.

A. The housing reinforces the ceramic.

Q. Does the housing also lend physical support to the ceramic liner with respect to any bending forces that may be applied during installation?

A. Yes.

(Roskam CPX-5 at 82, 83).

434. Mr. Roskam also testified:

Q. Does the housing [in the Krohne ceramic construction, the X-1000] in any way support the middle portion of the spool between or the liner between the end of the liner?

A. No

Q. Does the housing support the liner to reinforce the liner against fluid pressure?

A. No.

Q. Does the housing support the liner or reinforce the liner against compressive forces when it is mounted into a pipeline?

. . .

A. No.

(Roskam CPX-5 at 98, 99).

435. Mr. Stevens has not received a formal degree. His specialty is heavy engineering. The engineering is general engineering and control techniques, measurement and control techniques. He began his employment with Krohne in 1954. He is in charge of the office of technical draftsman at Krohne. He worked onto the development of the X-1000 or DELTAFLUX flowmeter at end of 1980. (Stevens CPX-10 at 4, 5).

436. Mr. Stevens in the development of the X-1000 and DELTAFLUX flowmeter cooperated in the design work. At meetings he attended the forms and the processing of the ceramic material was discussed. Krohne wanted to get pieces of ceramic tubes for compression tests. The samples obtained were simply tubes with electrodes inserted. Stevens participated in the testing of the pieces. (Stevens CPX-10 at 6, 7, 8, 9).

437. Krohne did a compressed air test to check the seal between the ceramic material and the electrode. Krohne also tested for the tightness of the platinum electrode. (Stevens CPX-10 at 10).

438. Mr. Stevens testified:

Q. Can you describe to me what that document is [dep. exh. 30]?

A. This is a report issued by the technical supervisory agency on tests made on aluminum oxide bodies, ingots.

Q. Did Krohne submit an electromagnetic flowmeter to this institution for testing?

A. Yes.

Q. Did this company test the entire flowmeter or just portions of it?

A. Only portions of it.

Q. And what portions did it test?

A. The ceramic body.

Q. For what reason did they test the ceramic body?

A. We wanted to receive a test certificate issued by an independent organization, and at the same time we wanted to have confirmation of our own tests.

(Stevens CPX-10 at 23, 24).

Admissions By Respondents

439. In a response dated April 25, 1986 respondents admitted:

(a) The Sybron British patent 1,424,875 shows an electromagnetic flowmeter transducer having a stainless steel cover (10).

(b) The Sybron British patent 1,424,875 shows an electromagnetic flowmeter transducer which does not have a cylindrical metal housing subjected to a compressive force effecting a fluid seal.

(c) The Sybron British patent 1,424,875 shows an electromagnetic flowmeter transducer which does not have a cylindrical metal housing which joins with electromagnetic coils to define a magnetic circuit therewith.

(d) Since December 20, 1983 Krohne America Inc. has offered for sale and sold in the United States ALTOFLUX X-1000 and DELTAFLUX magnetic flowmeters.

440. The basic problem to be solved by the invention of the '982 patent was a lower cost magnetic flowmeter system which was solved primarily by the reduction in materials, elimination of flanges, utilization of the housing for magnetic return path and use of solenoid coils. The invention of the '982 patent involved recognizing that there was only needed a diameter and a half of meter as far as length, that the housing also became the magnetic return path and that the coil system could be greatly simplified. A diameter and a half length was sufficient to eliminate external effects from magnetic flanges. (Schmoock CPX-13 at 5, 6).

441. Referring to a Schmoock invention disclosure dated July 12, 1979 and the associated drawings (Bates 03116 and 03117) which was the basis for Schmoock U.S. patent no. 4,253,340 (respondents' deposition exhibit K-4), Schmoock testified that the drawings are that of a flangeless flowmeter; that the purpose of the metal housing in the drawings is a magnetic return path and also a mechanical structure to hold the meter in the tube and to hold the base

for the electronics that will be added; that the purpose of the tube is to hold the liner and the electrode system; that the liner is an insulating material that prevents contact for the fluid by everything except the electrodes; and that the housing takes compressive forces through the spool (Schmoock CPX-13 at 15, 23, 34, 52).

441a. Schmoock testified:

Q. Is there any other spool that you use in you mini-mag series other than a lined stainless steel spool?

A. That is the only thing that is being sold. We are again--

. . .

Q. And in the ceramic spool design, the spool will be gutted up against the pipe flanges?

A. Yes.

Q. And it will have to withstand the compressive forces?

A. Yes.

. . .

Q. There is no other spool element to help the ceramic take the compressive forces?

A. No. There is the housing.

Q. Does that also have a gap in any of the units between the housing when it is installed and the pipe flanges?

A. Yes.

Q. That is after the bolts are tightened and there is still some gap?

A. Yes.

Q. So the housing doesn't directly bear any compressive forces?

A. No directly. Indirectly.

Q. Indirectly via the ceramic spool?

A. Yes.

Q. So, effectively, the ceramic spool receives opposing forces from the pipe flanges at either end and is immediate from the reaction force of the housing which the ceramic spool is forced when the bolts are tightened?

...

Q. And from the --let me rephrase the question.

The ceramic spool receives opposing forces from, on the one hand, the pipe flanges at either end of the spool, and on the other hand, from the reaction forces of the housing; is that correct?

A. I have a problem here. I am not totally familiar with the mechanics of that German system. How much--I don't know how much the force is transmitted to the body or how much the body withstands of the compressive force of the flanges. I just simply do not know because this design, like I said, came over from Germany and we are simply documenting it for our production.

Q. Is it fair to say that the ceramic spool is in contact with the housing?

A. It is in contact with the housing via two-inch stainless steel bands that are welded to the housing.

Q. And the ceramic spool is also squeezed between the pipe flanges?

A. Yes.

Q. And a compressive force is applied to the ceramic spool when the bolts on those pipe flanges are tightened?

A. Yes.

Q. And some part of that force is also transmitted through the ceramic spool to the housing?

A. That I can't answer with certainty. That would depend on how--I guess in the customer's gaskets. He could use gaskets so there would be no force applied to the housing or you could use gaskets that would transmit a portion to the housing.

Q. To whom do you report?

A. John Yard.

Q. To whom does Mr. Yard report?

A. Hubert Riester.

(Schmoock CPX-13 at 51, 52, 53, 54).

441b. Horst Focks who started with Krohne in 1962 and became central business manager for sales and marketing in 1982 testified in deposition:

(CPX-11 at 4, 11, 15-19):

Q. Did there come a time, Mr. Focks, when you became aware of any discussions at Krohne regarding a flangeless magnetic flowmeter?

A. Yes.

. . .

Q. When was that?

A. About 1965, '66.

Q. Please describe the circumstances surrounding your awareness of these first discussions.

. . .

A. As far as I can remember, it was at a sales discussion.

. . .

Q. Do you recall what was said?

A. Not in detail

Q. Tell us generally what was said.

A. As far as I can remember, it was a discussion about one particular application where it was necessary to reduce the volume of the flowmeter.

. . .

Q. Did there come a time when again there was a discussion regarding the advisability of having a flangeless flowmeter?

A. No.

Q. Did there come a time when it was decided to develop a flangeless flowmeter?

. . .

A. There have been discussions on how to reduce the size of magnetic flowmeters.

Q. And the first such discussion was in 1965 or '66; is that correct?

A. That's right.

Q. Was there a next discussion?

A. As far as reduction of size is concerned, there were continuous discussions.

Q. Describe for us the first such discussion where you recall the participants.

A. I think it was 1981.

Q. Who was present at the discussion?

A. Mr. Rademacher-Dubbick, Mr. Roskam, Mr. Mohrmann and myself. That's what I can recall.

Q. Do you recall what was said at this discussion?

A. The question isn't clear to me.

Q. What did you say at this discussion?

A. I advocated reducing the size of the magnetic flowmeter.

. . .

Q. Do you recall generally what Mr. Dubbick said?

A. I think he was in favor of the project.

Q. And Mr. Roskam, was he in favor of the project?

A. As far as I can remember, yes.

Q. For what reason were you in favor of a flowmeter having a smaller volume?

A. The technical possibilities for this existed.

Q. What were the advantages, if any, of such a project?

A. It made it possible to compete with other systems of flowmeters.

Q. In particular what other systems of flowmeters would you compete with?

A. Vortex flowmeters, instruments.

Q. Any others?

A. Oval gear counters, differential pressure systems, turbine counters.

Q. And other large-sized magnetic flowmeters?

A. Ultrasound flowmeters.

Q. Any others?

A. I can't think of any others at the moment.

Q. Would such magnetic flowmeters having a smaller volume also compete with existing magnetic flowmeters?

A. No.

Q. Was it intended that these magnetic flowmeters having a smaller volume would establish a new market?

A. Yes.

...



IMPORTATION AND SALE

442. Sales of magnetic flowmeters by Krohne GmbH. to Krohne America were as follows (in units):

	<u>1983</u>	<u>1984</u>	<u>Jan.-Oct. 1985</u>
ALTOFLUX DELTAFLUX (SX-3, at 11, Ans. to Int. No. 8(f)).			

443. Sales of magnetic flowmeters by Krohne America were as follows (in units):

	<u>1982</u>	<u>1983</u>	<u>1984</u>	<u>1985</u>
ALTOFLUX DELTAFLUX (PRX-12).				

444. Sales of magnetic flowmeters by Krohne America of meters two inches or larger were as follows (in units):

	<u>1982</u>	<u>1983</u>	<u>1984</u>	<u>1985</u>	<u>1986( 1st quarter)</u>
ALTOFLUX DELTAFLUX (PRX-12).					

445. Krohne America imported magnetic flowmeters from Krohne Germany between 1/83 and 10/85. Of these, Krohne America sold from 8/82 through 3/86. Of the sold by Krohne America, were of sizes two inches or greater sold after 1983. (SX-3 at 11, Ans. to Int. No. 8f, SX-4, Att. A; PRX-12).

446. Between 1/84 and 3/86 F&P sold magnetic flowmeters; of these, an estimated percent, or were of sizes 2 inches or larger. (CX-2 at 45, Tr. 490).

447. Krohne's sales represented            percent of total Krohne and F&P sales in 1984,            percent in 1985, and            percent in the first quarter of 1986 (based on: Krohne 2-4 inches in diameter;            percent of F&P sales). (FF 444, 490).

#### DOMESTIC INDUSTRY

448. Prior to the hearing, complainant stipulated that its MINI-MAG and K-MAG flowmeters in sizes less than two inches were not made in accordance with the claims of the patent in issue. Therefore, the domestic industry for the purpose of this investigation consists of F&P's facilities devoted to the research, development, manufacture, marketing and servicing of the MINI-MAG and K-MAG meters in sizes two inches and above. (Joint Resp. to Order 7 and 9, at 4).

449. F&P sells two models of flowmeters manufactured under the '982 patent; these flowmeters are designated by the trade names MINI-MAG and K-MAG. The '982 patent issued on December 20, 1983. (CX-2 at 5; PX 166).

450. MINI-MAG can handle the vast majority of aqueous solutions and slurries, whether viscous, corrosive, dirty or abrasive. It contains a non-magnetic spool having a molded or ETFE fluoropolymer, TEFZEL liner, which has essentially the same outstanding resistance to chemicals as Teflon. The MINI-MAG is offered with two corrosive resistance electrode holder materials: tantalum or zirconium. The electrode itself is tungsten carbide. (CX-1, 5-6)

451. The K-MAG is essentially the same as the MINI-MAG in its construction and operation. The K-MAG is provided with a ceramic flow spool for those applications for which the Tefzel liner is not suited. The K-MAG is offered only with platinum electrodes. (CX-1 at 6).

452. The MINI-MAG and K-MAG may be purchased with either integral or remote electronics. The integral electronics or signal converter is mounted on the flowmeter itself while remote electronics are mounted at a standard distance of 30 meters, (100 feet) with option for greater distances.

Approximately                    percent of F&P's sales are with remote electronics. (SX-22; CX-12; SX-15; SX-16; Tr. 492).

453. Approximations of how many of F&P's MINI-MAG and K-MAG meters are sold with remote electronics have ranged from                    percent. Respondents in their reply findings state that only about 45 to 50 percent of the F&P sales are with remote electronics. Staff puts forth this figure as well. (SX-5 Ans. to Int. No. 2 (f-g); RRF E 12b.; RFF E130; SFF 121; GFF 221).

454. F&P's research and development program in the U.S. employed approximately            people in 1983,            people in 1982 and            people in 1981. (CX-1 at 6).

455. F&P has a total of            square feet of its Horsham facility dedicated to research, development and testing of its flangeless electromagnetic flowmeters. These facilities include various offices, drafting and lab space and a model making shop. (CX-1 at 6).

456. In addition to standard office equipment, the equipment used by F&P for research, development and testing of its MINI-MAG and K-MAG includes experimental flow testing facilities and model making equipment. With respect to the electrical components, F&P's research and development equipment includes various electronic equipment including oscilloscopes, digital volt meters and a CAD/CAE computer for printing circuit development. F&P also utilizes various environmental test equipment in the research, development and testing of its MINI-MAG and K-MAG products. (CX-1 at 6-7).

457. There are approximately full time employees devoted to research, development and testing of F&P's MINI-MAG and K-MAG products. These include engineers, drafting/design employees, technicians, a model maker and a technical writer. (CX-1 at 7). Although staff suggested, based on Mr. Schmook deposition testimony, that there are approximately individuals devoted to R&D related to the products at issue, Mr. Schmook was referring to the number of persons assigned to the flow product and analytical instrument development group and there is no evidence that the figure he gave was related solely to the individuals working on the meters in issue. (CPX-13 Schmook Tr. at 55).

458. F&P has spent approximately on R&D related to the products at issue, and normally budgets approximately percent of its gross sales on R&D for all products. (SX-45; SX-6 Ans. to Int. No. 21 at 26; CX-1 at 7-8; CX-34).

F&P's TOTAL U.S. R&D BUDGET

BUDGET FOR MINI-MAG/K-MAG

<u>YEAR</u>	<u>\$(000)</u>
1979	
1980	
1981	
1982	
1983	
1984	
1985	

<u>YEAR</u>	<u>MINI-MAG \$(000)</u>	<u>K-MAG \$(000)</u>
1979		
1980		
1981		
1982		
1983		
1984		
1985		
Total		

(CX-1 at 8).

459. F&P dedicates approximately square feet of its Warminster facility and approximately square feet of its Vineland, New Jersey plant to manufacture, repair and quality control activities for its MINI-MAG and K-MAG products. square feet of the above described

facilities are dedicated to testing and calibration of these products. (CX-4 at 1).

460. Equipment used for the manufacture, repair and quality control of F&P's MINI-MAG and K-MAG products includes a sophisticated machine shop, testing equipment and flow loop calibration equipment. (CX-4 at 2).

461. F&P employs approximately      people, on a full time basis, for the manufacture, repair and quality control for the patented meters. These employees include machinists, mechanical parts assembly employees, electronic assembly employees, quality control individuals, manufacturing engineers and product engineers. (CX-4 at 2). It should be noted however, that in an answer to a staff interrogatory the number of individuals so employed was put at      There is no explanation for this discrepancy. (SX-6 Ans. to Int. No. 2 at 5).

462. F&P's design engineers have at least a bachelor's degree in either mechanical or electrical engineering, and over half of them have masters' degree in an engineering discipline. (Tr. at 98-99).

463. F&P's customers include major, domestic participants in the petrochemical, pulp and paper, food, metal, mining, electrical power generation, marine and aerospace industries. Other customers include manufacturers who process raw materials, and municipalities and industries that require water and sewage treatment and control. (CX-2 at 2).

464. F&P employs approximately      full time sales persons,      sales support persons and      independent manufacturing representative firms. F&P has approximately      separate sales offices located throughout the country including regional offices located in New York, Houston, Chicago and Atlanta. (CX-2 at 2).

465. F&P also employs regional engineers with respect to sales and approximately marketing persons. The sale personnel devote approximately percent of their time, and the marketing personnel, percent of their time, to the sale and marketing of MINI-MAG and K-MAG products. (CX-2).

466. Since the MINI-MAG was introduced in 1981, and the K-MAG in 1985, F&P has spent close to on advertising these products. (CX-2, at 3).

467. Advertising, marketing and selling expenditures for the MINI-MAG and K-MAG for the years 1981 through 1985 are as follows:

<u>YEAR</u>	<u>AMOUNT</u>
1981	
1982	
1983	
1984	
1985	

(CX-2, at 3).

468. As of December 31, 1985, F&P employed approximately persons in the United States. F&P provides benefits for its employees, including group life insurance, sick pay, hospitalization, and surgical and medical benefits. F&P has a non-contributory, defined benefit compensation plan for U.S. employees that meet certain eligibility requirements. (CX-3 at 2).

469. F&P also provides benefits such as an incentive savings plan, under which common shares of the company may be purchased by most employees. (CX-3 at 2).

470. When F&P began to manufacture its MINI-MAG and K-MAG flowmeters, it did not modify any of its existing equipment. Rather, F&P capitalized its various equipment needed to manufacture, test and market the patented meter. Initial capitalization took place in 1981. (CX-4 at 2).

471. F&P has expended over \_\_\_\_\_ in tooling and associated equipment used for the design and development of the manufacturing, testing and repair processes used for the patented meters. (CX-4 at 2).

472. This capitalization included the purchase of die cast tooling, calibration rigs, investment casting dies and injection molding equipment, including dies and various welding fixtures. (CX-4 at 2).

473. F&P has developed various manufacturing instructions for both the mechanical and electrical MINI-MAG and K-MAG components. F&P has also developed specific inspection procedures for the signal wiring, U-S wiring, potting techniques, liners and probes used in these products. (CX-4 at 3).

474. F&P employs sophisticated quality control procedures which begin at the "components level" and continue through final assembly. A fully automated, electronic testing facility is located in Vineland, New Jersey. F&P recently expended more than \_\_\_\_\_ for the largest, most modern calibration facility in the United States. (CX-4 at 3).

475. F&P has developed a hydrostatic test and calibration procedure to assure that the MINI-MAG and K-MAG meters meet advertised pressure and accuracy ratings. F&P also has developed specific welding procedures, equipment and jigs including a test and welding positioner for the manufacture of the MINI-MAG and K-MAG meters. (CX-4 at 2).

476. Many of the above procedures (FF's 471-75) relate solely to the MINI-MAG and K-MAG meters. However, they may also be used for manufacture and testing of other flowmeters. (CX-4 at 4).

477. F&P anticipates investing an additional \_\_\_\_\_ within the next two years to enhance the manufacturing facilities for the MINI-MAG and K-MAG meters. (CX-4 at 3).

478. F&P has applied a predetermined engineering time system to the MINI-MAG. (CX-4 at 4).

479. The safety methods which have been in place at F&P with respect to the production of other products remain. However, it is contemplated that within the next year an improved ventilation system will be installed in view of the potting techniques used by F&P in the manufacture of its MINI-MAG and K-MAG products. (CX-4 at 4).

480. F&P has also developed specific procedures for the production of the MINI-MAG and K-MAG. These procedures cover all phases of manufacturing, processing and equipment testing of both the electronic and mechanical components. (CX-4 at 4).

481. Below is a table of a summary of the manufacturing costs for F&P's MINI-MAG and K-MAG meters of sizes two inches and larger (in dollars).\*

MINI-MAG

<u>SIZE</u>	<u>ZIRCONIUM</u>	<u>TANTALUM</u>
2"		
3"		
4"		

K-MAG

<u>SIZE</u>	<u>COST</u>
2	
3	
4	

\*These manufacturing costs were calculated by adding a standard handling charge of 11 percent to the purchase price of the raw material to arrive at a "standard cost" figure for materials. To the "standard cost" figure the cost of machining, assembling and testing the particular product was added. This latter cost figure is arrived at by using the hourly rate for each department, including both direct labor and overhead. (CX-4 at 5).



482. The MINI-MAG and K-MAG flowmeters may be broken down into four major components: spool component, spool housing component, electronic component and electrical housing component. The annual production capacity for the MINI-MAG and K-MAG are summarized below.

	<u>COMPONENT</u>	<u>ANNUAL PRODUCTION CAPACITY</u>	<u>ACTUAL PRODUCTS</u>
1982	Spool Component Spool Housing Component Electronic Component Electronic Housing Component		
1983	Spool Component Spool Housing Component Electronic Component Electronic Housing Component		
1984	Spool Component Spool Housing Component Electronic Component Electronic Housing Component		
1985	Spool Component Spool Housing Component Electronic Component Electronic Housing Component		

(CX-4 at 6-7).

483. The actual production figures above are based on the actual units sold for the years shown and do not include the diversion of any equipment from other production activities. Further, the figures shown represent units produced by equipment dedicated exclusively to the production of the MINI-MAG

and K-MAG products. The production capacity figures were calculated on the basis that the present production equipment for the MINI-MAG and K-MAG products are only operating on a one shift basis. Moreover, the equipment is presently operating at one-half of its production capacity. Therefore, by fully realizing present equipment capability, F&P could double its production capacity on a one shift basis. It can then quadruple that basis by running said equipment on a two shift schedule. This schedule would not effect the quality of F&P's products nor would it require the purchase of any additional equipment. However, it would require employing additional machine operators and technicians. (CX-4 at 8).

484. F&P has promoted the products at issue at various trade shows and prints and distributes technical brochures, manuals, visual aids and training literature. (CX-2 at 3; CX-11; CX-12; CX-36 - CX-39).

485. F&P's MINI-MAG and K-MAG flowmeters incorporate numerous electronic and mechanical components which are supplied by more than vendors. Less than percent of the MINI-MAG components are manufactured outside the United States. (CX-4 at 6).

486. For the K-MAG, F&P purchases the cast ceramic spool from its German subsidiary which sources them from a German supplier. (CX-4 at 6).

487. The proportionate value of the ceramic spool viz a viz the total cost of raw materials and components used to manufacture the K-MAG flowmeter, inclusive of labor costs and general administration expenses, is approximately percent. (SX-46, Ans. to Int. No. 5).

488. K-MAG sales represent approximately percent of F&P's sales under the '982 patent. (SX-46, Ans. to Int. No. 5).

489. F&P maintains a finished inventory for the MINI-MAG and K-MAG meters. Below is a summary of F&P's year end inventory; however, size is not accounted for.

	<u>PARTS</u> <u>(\$000)</u>	<u>FINISHED GOODS</u> <u>(\$000)</u>	<u>TOTAL INVENTORY</u> <u>(\$000)</u>
1981			
1982			
1983			
1984			
1985			

(CX-2 at 7).

#### SUBSTANTIAL INJURY

490. F&P's sales revenue, gross profits, net profits, and sales volume for its MINI-MAG and K-MAG flowmeters are as follows (in thousands of dollars and units):

	<u>1982</u>	<u>1983</u>	<u>1984</u>	<u>1985 1/</u>	<u>Jan.-Mar.</u> <u>1986</u>
MINI-MAG:					
Sales Revenue-----					
Gross Profits-----					
Net Profits-----					
Unit Sales-----					
K-MAG:					
Sales Revenue-----	-	-	-		
Gross Profits-----	-	-	-		
Net Profits-----	-	-	-		
Unit Sales-----	-	-	-		

1/ Sales of the K-MAG began in April 1985.  
(CX-2 at 5; SX-5, Ans. to Int. No. 7(a-b); RX-21 at 007427-28).

491. F&P does not maintain sales and profitability figures on the basis of unit size for MINI-MAG and K-MAG flowmeters. (RPX-14 at 2-3, No. 8).

492. F&P's magnetic flowmeters of two inches and greater in diameter represent approximately percent of its unit sales. This estimate was made by F&P's business manager for flow products, who has held that position since

about 1981. The business manager has responsibility for the sale of all flow products including MINI-MAG and K-MAG flowmeters, and is thoroughly familiar with F&P financial data such as profits and sales. (Dimm, Tr. at , 480-81, 490, 508-509; CX-2, Dimm WS at 1).

493. Krohne's unit sales of flangeless magnetic flowmeters of sizes 2-4 inches accounted for the following percentages of its total flangeless magnetic flowmeter unit sales during 1983-84:

1983-----  
1984-----  
1985-----

(RPX-12).

494. The items that accounted for the difference between F&P's sales price and its net profit are sales expenses        percent of net billings), administration expenses        percent of net billings), and interest, R&D, and corporate expenses        percent of net billings). (SX-6, Ans. to Int. No. 13(g)).

495. As of December 31, 1985, F&P had the following number of flowmeters in inventory:

MINI-MAGs-----  
K-MAGs-----

(SX-5, Ans. to Int. No. 7(d)).

496. F&P's end of year inventory for parts and finished MINI-MAG and K-MAG flowmeters was as follows (1,000 of dollars):

	<u>Parts</u>	<u>Finished Goods</u>	<u>Total</u>
1981-----			
1982-----			
1983-----			
1984-----			
1985-----			

(CX-2 at 7).

497. In 1985, F&P's production capacity for the MINI-MAG flowmeter, based on one shift, was        units per quarter. (SX-6, Ans. to Int. No. 3).

The Overall Market

498. F&P's estimate of 1986 market demand for flangeless electromagnetic flowmeters is in excess of 10,000 flowmeters, based on F&P's estimated sales of about 4,000 to 5,000 flowmeters and its estimate of a      percent market share. (SX-6, Ans. to Int. No. 10).

498(a). F&P's market share in the magnetic flowmeter market (flanged and flangeless) was estimated in an independent study (Frost and Sullivan Report) at 27 to 30 percent. Krohne's market share was not cited individually, as Krohne was included within a group of firms with a combined market share of 20 to 22 percent. (CX-20 at 00411).

498(b). The Frost and Sullivan study in which market share information was estimated was cited by respondents in regard to United States market share information for flangeless electromagnetic flowmeters. Respondents have relied on Frost and Sullivan reports as late as 1985, including written reports using Frost and Sullivan information, in assessing the flowmeter market. (SX-1, SX-2, Ans. to Int. No. 36; SX-3, SX-4 at Int. No. 8(g)); CPX-11, Focks Dep. at 31-37).

498(c). Based on an assumption of an F&P market share of 27 percent in the magnetic flowmeter market, and that      percent of F&P's sales of flangeless flowmeters are 2-4 inches in diameter, sales and market shares in the magnetic flowmeter market, 2-4 inches in diameter, would be as follows (units and percentages):

	<u>1982</u>		<u>1983</u>		<u>1984</u>		<u>1985</u>	
	<u>units</u>	<u>%</u>	<u>units</u>	<u>%</u>	<u>units</u>	<u>%</u>	<u>units</u>	<u>%</u>
F&P-----								
Krohne----								
Other-----								
Total----								

(FF 444, 490, 492, 498(a), 498(b)).

498(d). Using complainant's market share estimate of      percent, rather than the 27 percent derived from the Frost and Sullivan report on which respondent relies, would increase Krohne's market share because the resultant estimated market would be smaller. (See FF 498(a-c)).

499. There are a number of manufacturers of various types of flowmeters. The following is a listing of the major types of flowmeters: (1) differential pressure; (2) magnetic; (3) turbine; (4) positive displacement; (5) variable area; (6) mass flow; (7) ultrasonic; and (8) vortex. (RX-86-106; RX-150).

500. Market demand for magnetic flowmeters was forecast to decline by about 4 percent in 1986. (CX-20 at 00402).

501. The F&P K-MAG was not intended to replace the TEFZEL-lined MINI-MAG, but was intended to be sold for those applications beyond the limits of the MINI-MAG. These include applications where temperature is between 250 degrees and 356 degrees Fahrenheit, where sanitary requirements are strict (i.e. dairy products), and where abrasion or corrosion resistance is important. (PX-21 at 007427-28; RX-22 at 04720; See RX-27-28; SX-20; PX-35 at 04402, 04406; RPX-9, Dewey Dep. at 30; Riester, Tr. at 470-71; CX-1, Riester WS at 6; CPX-18, Gevert Dep. at 35-36).

502. The F&P MINI-MAG can be steam cleaned at a temperature of 300 degrees Fahrenheit, if care is taken with respect to the temperature of the liquid following steam cleaning to prevent thermo-shock. (CPX-33, Dep. Ex. 7007 at 11).

503. Krohne's flowmeters with ceramic spools also have the advantages of corrosion and abrasion resistance, use at higher temperatures, and where sanitary requirements are strict. (PX-40; RX-41; See RPX-9, Dewey Dep. at 30; RX-3, Liptak WS at 5-6, 10-11; Liptak, Tr. at 1433-34).

504. According to Mr. Reister, those applications where a ceramic liner would be critical account for about 10 percent of the magnetic flowmeter market. (Reister, Tr. at 470).

505. Applications where the use of a ceramic spool is critical is for radiation applications and where non-chafing is important. Krohne customers that use flowmeters for these application include

Other types of flowmeters could be used for these applications, however, but a flowmeter with a ceramic spool is far superior with respect to longevity. (Beahm, Tr. at 1069-72, 1085-87).

505(a). Krohne believed the MINI-MAG, offered by F&P would be a of the new instrumentation it was developing that would eventually be called the X-1000. (CX-57 at 6, Translation) F&P has made sales of its magnetic flowmeters which have interfered with Krohne's sales and market share in the U.S.. (CPX-11 at 53-54, 59)

505(b). Mr. Beahm reported to Mr. Focks that  
(CPX-11 at 60)

506. F&P's only competition with respect to ceramic-lined flangeless magnetic flowmeters is Krohne. (SX-20 at 04720).

507. For some magnetic flowmeter customers, the properties of the ceramic spool are an important, if not the most important, consideration in their decision to purchase a magnetic flowmeter from Krohne. (See RX-5, Igoe WS at 1; Igoe, Tr. at 813-16, 819, 842-43; RX-6, Foster WS at 1; RX-7, Williams WS at 1; RX-4, Johnson WS at 2-3).

508. Magnetic flowmeters compete against magnetic flowmeters, whether or not flanged, and flowmeters generally compete against flowmeters, irrespective of type. (Beahm, Tr. at 1076-77; RX-1, Beahm WS at 28; Dimm, Tr. at 484; Esposito, Tr. at 1120; CPX-11, Focks Dep. at 52, 55-59; SX-12; SX-13; CX-20; CX-97; RX-42 at 01911-12; RX-65 at 007002; RX-85 to RX-88).

509. Magnetic flowmeters measure the flow of fluids such as water, sewage, slurries (fluid containing solid particles), pulp, pastes, juices, acids, lye, food products and other liquids and steam which have a minimum conductivity of five microsiemens per centimeter. The F&P MINI-MAG and K-MAG flowmeters, and the Krohne ALTOFLUX X-1000 flowmeter have a minimum conductivity of 5 microsiemens per centimeter. The Krohne DELTAFLUX flowmeter has a minimum conductivity of 20 microsiemens per centimeter. Both the F&P MINI-MAG and K-MAG have an overall accuracy rating of 1.0 percent. The Krohne K-MAG has an accuracy rating of 0.5 percent, and the Krohne DELTAFLUX has an accuracy rating of 2.0 percent. (Reister, Tr. at 108; SX-15 at 501317; SX-16 at 501365; SX-33 at 501613; SX-34 at 501602; CX-12 at 00037; CX-36 at 01811; CX-29 at 00774; CX-30 at 00787).

510. The internal diameter of the spool of a magnetic flowmeter must match the internal diameter of a user's pipe. Therefore, manufacturers of magnetic flowmeters must produce flowmeters of many different sizes. (Reister, Tr. at 258-59).

#### Flangeless vs. Flanged Flowmeters

511. F&P produces and sells two models of flangeless magnetic flowmeters. The MINI-MAG (model 10D1475) was introduced in March 1982, and has a non-magnetic spool with an insulating TEFZEL liner; the K-MAG (model 10D1476) was introduced in April 1985, and has a ceramic (aluminum oxide) spool. (Reister, Tr. at 253-54; CX-36; CX-37; SX-5, Ans. to Int. No. 1; SX-6, Ans. to Int. Nos. 6, 8).

512. The introduction of the MINI-MAG and K-MAG flowmeters led to an improvement in F&P's unit sales of magnetic flowmeters having a diameter of four inches and less over F&P's prior models in this size range. (Reister, Tr. at 468-69).



513. Flangeless flowmeters (or wafer type design) are inserted between two pipes and are attached to the two pipes by bolts passing through the end flanges of the pipes, the bolts either passing through the flowmeter or encasing the flowmeter. (SX-15-16; RX-163; CX-82; RX-189).

514. Large flowmeters are very awkward in the flangeless variety with respect to installation, and therefore generally have flanges. (Beahm, Tr. at 1096).

515. Flanged flowmeters are attached to the upstream and downstream pipes by bolting the flanges at each end of the meter to the end flanges of the two pipes. (Reister, Tr. at 116, 255; CX-83 at 2-3 of applicant's discussion of prior art; CPX-22).

516. Manufacturers of flanged magnetic flowmeters must produce them with flanges that correspond to several different standards, such as ANSI, "British Standard Flanges," and DIN. For the flangeless flowmeter, however, the type of flanges on the pipe are not critical. (Reister, Tr. at 116-117, 120-121).

517. For high pressure applications or vacuum applications, the use of flanged flowmeters would be necessary. For pressure ranges from 1 bar to 10 bar, in which the pipeline is subject to low stresses, flangeless flowmeters can be used. (CPX-19, Kiene Dep. at 18-19).

518. For various reasons, some customers of magnetic flowmeters prefer flowmeters with flanges. These reasons include ease of installation and proper alignment. (RX-4, WS at 3; RRX-3, Mannion Rebuttal WS at 1-2; RRX-4, Nerbun Rebuttal WS; RRX-5, Esposito Rebuttal WS at 2; See RRX-6; Beahm, Tr. at 1076-1078; Reister, Tr. at 466).

519. Some firms that are major users of flowmeters stated that they do not consider the flangeless design as a factor in deciding which magnetic flowmeter to purchase. (RX-4, WS at 2-3; RX-5, WS at 2; RX-6, WS at 2; RX-7, WS at 2).

520. The following sell flangeless magnetic flowmeters in the United States: Fischer and Porter, Krohne, Brooks Instrument Div.; Yokogawa Hokushin; Endress & Hauser; Toshiba; Yamatake-Honeywell; Danfoss; Dynasonics; Heinrichs; Hitachi. (SX-1, Ans. Int. No. 37(a)).

521. a Krohne report on the development of the X-1000 meter said that the purpose was to

(SX-37 at 700055).

522. Respondents have not promoted the flangeless design of their accused flowmeters in their recent advertisements. (Esposito, Tr. at 1169, 1171-1172, 1181; RX-1, Beahm WS at 29; RX-8, Mannion WS at 5-8; RX-9, Seelaus WS at 5, 8; RX-10 at 3; SX-33; SX-34; RX-41).

523. One purchaser of flowmeters stated that his statement that the flangeless design was not a factor was based on the assumption that there was no relationship between the flangeless design and size, weight, or cost. , Tr. at 929).

524. Purchasers from industries that are major users of flowmeters stated that the physical size of a flowmeter was a consideration when purchasing meters. Weight was generally not as important a consideration. ( , Tr. at 826, 830; RX-6, WS at 2; , Tr. at 875, 888; Williams, Tr. at 928-929).

525. According to the size of the meter was important relative to the size of the mag head itself, which afforded the ability to mount the meter closer to the wall. The weight of a meter is not really of importance to (Igoe, Tr. at 826).

526. All of the Krohne X-1000 flowmeters purchased by \_\_\_\_\_ were under 1/2 inch in diameter. ( \_\_\_\_\_, Tr. at 842).

527. \_\_\_\_\_ prefers to purchase flowmeters of various sizes from the same manufacturer because of simplicity of maintenance and spare parts. ( \_\_\_\_\_, Tr. at 872).

528. According to \_\_\_\_\_ where the pipes are close together, the compactness of the flowmeter is essential in most cases. The weight of the flowmeter is not a factor. ( \_\_\_\_\_, Tr. at 875-876, 888-889).

529. According to \_\_\_\_\_ it normally takes a few more inches for flanges to be attached to the end of a flowmeter, but accuracy is still a more important consideration over whether a meter is flanged or flangeless. ( \_\_\_\_\_, Tr. at 891-893).

530. All of the Krohne X-1000 flowmeters purchased by \_\_\_\_\_ were under 1 1/2 inch in diameter. ( \_\_\_\_\_, Tr. at 864).

531. According to Mr. Appel of F&P GmbH, the term "compact" as applied to flowmeters means that the electronic converter is integrally mounted on the primary, as opposed to being remote from the primary. (CPX-16, Appel Dep. at 6-7).

532. In response to a question concerning the importance of size to a customer, Mr. Esposito responded that compactness is important; he noted that the face to face dimension, the total space taken up by the flowmeter to operate properly, and the amount of straight upstream and downstream pipe from the meter required for proper operation were important considerations. (Esposito, Tr. at 1125-1129, 1131-1133).

533. Pulsed DC field electronics contributed to reductions in size and weight of Krohne's ceramic-lined flowmeters. (RX-41 at 500364; RX-11, Hoffman WS at 6-8, 12; RX-1, Beahm WS at 26-28; Beahm, Tr. at 1021; See FF 538).

533(a). Krohne began discussing the concept of a flangeless magnetic flowmeter as early as

If the volume of the flowmeter were reduced, magnetic flowmeters could then compete with other systems of flowmeters including; vortex flowmeters, oval gear counters, differential pressure systems, turbine counters, and ultrasound flowmeters. Such a meter would not have competed with existing flowmeters. Instead these smaller meters were intended to establish a new market. (CPX-11 at 15-19, 23).

534. An AC magnetic flowmeter would tend to be larger than a DC magnetic flowmeter. ( , Tr. at 831).

535. The shape and type of coil used in a magnetic flowmeter will affect the flowmeter size. (Riester, Tr. at 250-251; Beahm, Tr. at 1021).

536. Krohne's flanged M950 flowmeter, which ranges in diameter from 1 1/2 to 12 inches, uses the T 900 signal converter, which has a pulsed DC field. Krohne's flangeless X-1000 flowmeter uses the same T 900 signal converter. The M950 flowmeter uses a non-magnetic measuring tube with an insulating tube liner. The X-1000 flowmeter uses an aluminum oxide (ceramic) measuring tube. (CX-48 at 500422-26; See Esposito, Tr. at 1125).

537. Krohne also sells a "compact" flanged flowmeter with AC electronics, the K350. This flowmeter uses a measuring tube of stainless steel with a neoprene or PTFE liner. (CX-48 at 500446).

538. A comparison of the heights and weights of Krohne's comparable-diameter X-1000 (flangeless DC), M950 (flanged DC), and K350 (flanged AC) flowmeters is as follows (in inches and pounds):

	Length 1/			Height		
	X-1000	M950	K350	X-1000	M950	K350
2 inch-----	4.19"	7.88"	13.75"	8.25"	10.13"	13.56"
3 inch-----	6.13"	7.88"	13.75"	8.69"	10.88"	14.69"
4 inch-----	8.13"	9.88"	13.75"	9.81"	13.25"	15.50"

	Width 2/			Weight		
	X-1000	M950	K350	X-1000	M950	K350
2 inch-----	4.00"	7.25"	8.38"	13.2	31.0	88.0
3 inch-----	5.13"	7.25"	8.38"	14.3	37.0	99.0
4 inch-----	6.13"	9.25"	8.38"	22.0	62.0	110.0

1/ The face-to-face measurement of the flowmeter.

2/ The cross-sectional distance of the widest circular section of the flowmeter. (CX-48 at 500423, 500425, 500446-447; See RX-175).

539. Both flangeless design and pulsed electronics have made magnetic flowmeters more competitive in the market relative to other types of flow measuring devices. (CX-20 at 00383-84).

540. Krohne has offered since sometime in 1985 a flanged electromagnetic flowmeter that uses a ceramic flow tube (the ALTOFLUX X-2000), which is available in diameters from six inches to 12 inches. (Esposito, Tr. at 1154).

541. A flanged flowmeter of a given spool internal diameter has a higher cost and market price than a flangeless magnetic flowmeter having the same spool inside diameter. (CX-1, Reister WS at 4; Reister, Tr. at 464-466; RX-107; CPX-34).

542. Flangeless magnetic flowmeters are offered by only F&P, Krohne, Brooks, Endress & Hauser, Toshiba, and Yokogawa. (Reister, Tr. at 237; Esposito, Tr. at 1121; SX-15; SX-16; SX-31 to SX-35; SX-39; SX-40).

543. Brooks, Krohne, and Yokogawa produce both flanged and flangeless magnetic flowmeters as well as other types of flowmeters, and there is no identification as to what type of flowmeter they were offering in competition with F&P. (SX-12; SX-13).

#### Fischer and Porter's Ceramic Core Supply

544. F&P purchases the ceramic spool for its K-MAG magnetic flowmeter only from F&P GmbH. (Germany) which, in turn, acquires these components in Europe. The ceramic core with sintered electrodes for the K-MAG flowmeter was developed at F&P GmbH. (Reister, Tr. at 432; RRX-13 at 1-2; CPX-18, Gevert Dep. at 16-17, 29-30, 47-48; Dimm Dep. at 30-32, 3???, 37; CX-4, Stewart WS at 6).

545. Several companies have been or are potential or actual suppliers of ceramic cores to F&P GmbH. These companies include Feldmuehle (Germany), Haldenwanger (Germany), Friedrichsfeld (Germany), Serraverre (France), and Transceram (France). (CPX-18, Gevert Dep. at 40, 45; CPX-16, Appel Dep. at 42; CPX-19, Kiene Dep. at 3, 43, 57, 59-60; RRX-13 at 1-2.)

546. The ceramic cores from Feldmuehle and Serraverre were of an unsatisfactory quality and no ceramic cores from either of these companies were ever commercially used. (CPX-16, Appel Dep. at 42. CPX-19, Kiene Dep. at 59-60).

547. Transceram, a French company, has supplied ceramic spools to F&P Germany, but F&P Germany has used no ceramic spools from this company because the poor quality of the electrode seals made them unusable. (CPX-18, Gevert Dep. at 39-41).

548. In March 1984, F&P estimated that importing the complete ceramic spool assembly from Germany would cost (4-inch diameter spool) compared to its own manufacturing cost of (SX 41 at 05469).

549. In June 1984, F&P forecast 1985 sales of its K-MAG at units, at a net selling price of and after tax profits of per unit. The cost of importing the ceramic spool from F&P Germany was for a 4-inch spool, compared to F&P's manufacturing cost of for its MINI-MAG spool assembly. (RX-22; RX-154 at 05443).

550. F&P GmbH. made its first sale of a flangeless electromagnetic flowmeter with a ceramic core in late 1982 or early 1983. (CPX-18, Gevert Dep. at 30).

551. In January 1985, F&P was experiencing problems in obtaining ceramic spools from F&P Germany because F&P Germany's source of ceramic spools was no longer supplying such spools. The expectation at that time was that the spools would again be available in the summer of 1985. (RX-80 at 05401-402).

552. As of May 1985, the quality of the ceramic spools received from Germany was questionable, and there was a shortage of procurement of some production parts. (RX-80 at 05392).

553. In May 1985, F&P reported that "delays in K-MAG availability are now beginning to cause F&P to miss delivery commitments made in good faith to customers." (RX-80 at 05520).

554. In August 1985, F&P reported that "a potential problem exists in the future for the K-MAG because of the present unavailability of spool pieces from Germany." (RX-80 at 05502).

555. During 1984-85, F&P was investigating potential U.S. sources of supply for the ceramic spool, which included Coors, Lambertville Specialty

Parts and Bolt Technical Ceramics. F&P has not been successful in finding a domestic supplier. (RX-80 at 5401, 05466, 05464, 05405, 05399; Dimm Dep. at 93-94).

556. In December 1985, a report from F&P Europe indicated that the K-MAGs were out of the development phase and that in recent weeks F&P GmbH. had received very good ceramic tubes. F&P GmbH. expected overdue shipments of ceramic tubes to be delivered in January-February 1986. (SX-44 at 008200).

557. In February 1986, Haldenwanger Co. was supplying ceramic spools to F&P GmbH. Delivery dates for 350 spools that were due in February would not be kept. Of 75 completed ceramic spools, 43 were acceptable and were due for delivery to F&P GmbH. at the end of February. The delivery period from Haldenwanger for K-MAG spools was estimated at 4 months. (RX-81).

558. According to Mr. Appel, general sales manager for F&P GmbH., ceramic spools supplied by Haldenwanger to F&P GmbH. had already been tested by Haldenwanger, and by the time they reach F&P GmbH. the spools are tested okay. Mr. Appel was not aware of any problems encountered by F&P GmbH. in obtaining ceramic spools from Haldenwanger. (CPX-16, Appel Dep. at 3, 45, 52-53).

559. F&P GmbH. purchased ceramic spools from Friedrichsfeld and then purchased ceramic spools from Haldenwanger in late 1983 or early 1984 when Friedrichsfeld refused to supply ceramic spools to F&P GmbH. F&P GmbH. continued to purchase ceramic cores from Haldenwanger as of April 1986. As of April 1986, F&P GmbH. was experiencing difficulties with the ceramic spools from Haldenwanger, specifically that the electrode seals were inadequate. (CPX-18, Gevert Dep. at 37-39; CPX-19, Kiene Dep. at 57).



560. In March 1986, F&P GmbH. was offered a possible source of supply of ceramic spools produced by Friedrichsfeld. (CPX-18, Gevert Dep. at 52-54).

561. Three purchasers of magnetic flowmeters were either not aware of, or were only recently aware of, the fact that F&P had a ceramic spool magnetic flowmeter available for sale. (Igoe, Tr. at 822; Foster, Tr. at 896; Williams, Tr. at 921).

Overall Import Sales

562. Krohne America's sales and profits of flangeless magnetic flowmeters since 1983 for flowmeters of two, three, and four inches, are as follows (in dollars and units):

	<u>1983</u>	<u>1984</u>	<u>1985</u>
ALTOFLUX X-1000:			
Sales-----			
Gross Profits---			
Net Profits-----			
Units Sold-----			
DELTAFLUX:			
Sales-----			
Gross Profits---			
Net Profits-----			
Units Sold-----			

(RRX-12).

563. During January-March 1986, Krohne's sales volume of magnetic flowmeters was as follows:

	<u>ALTOFLUX X-1000</u>	<u>DELTAFLUX</u>
2 inch-----		
3 inch-----		
4 inch-----		
Total-----		

(RRX-12).

Lost Sales

563(a).

F&P CUSTOMER'S

KROHNE SALES GREATER THAN 2"  
QUANTITY      REVENUE

TOTAL

(\* Primaries only).

564. In May 1984, F&P signed an annual sales agreement with      for sales of 250 MINI-MAGs at a discount of      percent. The size of the MINI-MAGs to be purchased was not specified. (RX-29 at 05589-90).

565. Prior to purchasing Krohne magnetic flowmeters in 1983, was using F&P magnetic flowmeters, as well as other models. ( Tr. at 950).

566. In considering the Krohne magnetic flowmeter, was concerned with how well the meter could withstand abrasive materials, since different meters were being evaluated at a pilot plant for use with coal slurries, an abrasive application. ( , Tr. at 950).

567. The Krohne flowmeters were not purchased as direct replacements for F&P flowmeters, but were purchased because the Krohne ceramic lining out performed any other lining had had available at the time. concluded that the ceramic liner was superior to others for the coal slurry application and bought the original Krohne meters without opening the purchase to bids, based on the superior performance of the Krohne ceramic spool for this application. purchased ceramic flowmeters from Krohne during the 1983-1984 evaluation period. ( Tr. at 950-951, 955, 959; RRX-2, WS at 1).

568. During 1984 and 1985, the quantity and average unit prices for purchases of Krohne flangeless magnetic flowmeters of sizes 2- to 4-inches, including converters and cable, was as follows, based on Krohne invoices:

	<u>1984</u>		<u>1985</u>	
	<u>Quantity</u>	<u>Price</u>	<u>Quantity</u>	<u>Price</u>
DELTAFLUX:				
2 inch-----				
3 inch-----				
4 inch-----				

ALTOFLUX X-1000:

2 inch-----  
3 inch-----  
4 inch-----

(CPX-30 at 900006, 900354, 900435, 900528, 900554, 900220, 900014, 900312, 900139).

568(a). of the flowmeters in FF 568, valued at were purchased by from Krohne during September-October 1985, and flowmeter, valued at was purchased in April 1985. (CPX-30, at 900435, 900528, 900554).

569. In January 1985, purchased a Krohne 2-inch ALTOFLUX X-1000 primary for and three Krohne DELTAFLUX 2-inch primaries for apiece. (CPX-30 at 90034\*\*\*, 900355).

570. had originally purchased Foxboro flowmeters but changed to Krohne flanged flowmeters (K300 and M900 series) because of problems with Foxboro electronics. (RX-4, WS at 5).

571. In late 1982, switched from Krohne magnetic flowmeters with teflon liners to the Krohne ALTOFLUX X-1000 and DELTAFLUX (ceramic spools) for flowmeters of 4 inches in diameter or less, because it considered the ceramic spool to be superior in withstanding abrasive materials, and liked other features of the DELTAFLUX and ALTOFLUX X-1000. (RX-4, WS at 2).

572. During 1984 and 1985, purchases and average unit prices for Krohne flangeless magnetic flowmeters of sizes 2-4 inches was as follows, based on invoices that included price:

1984		1985	
Quantity	Price	Quantity	Price

DELTAFLUX:

2 inch-----  
 3 inch-----  
 4 inch-----

ALTOFLUX X-1000:

2 inch-----  
 3 inch-----  
 4 inch-----

(CPX-30 at 900004, 900075-76, 900122, 900176, 900377, 900392, 900439, 900512, 900476, 900514, 900558, 900553, 900560, 900093-94; 900086, 900108, 900135-36, 900172, 900247-49; 900226, 900583, 900577).

573. A major purchasing agent has not been approached by F&P for a number of years. The only contact with F&P was when he requested a catalog about 6 or 7 years ago. (RX-4, WS at 2, 17).

574. The invoices provided by F&P relating to sales to refer only to MINI-MAG X flowmeters sold during the period 1981-82. The MINI-MAG X is a flanged flowmeter. (CX-114).

575. provides systems for water and fructose treatment to selects the components for these systems. ( , RRX-1 at 2).

576. In November 1985, F&P bid for the sale of a MINI-MAG to and specified that the competition was Krohne and Yokogawa. F&P's discount was percent. F&P did not specify the size of the flowmeter. Based on F&P's list prices at that time, their offer price would have been \$1,817 for a 2 inch MINI-MAG, \$1,939 for a 3 inch MINI-MAG, and \$2,009 for a 4 inch MINI-MAG, if the offer had included flowmeters of these sizes. (SX-13 at 03371; See FF 666).

577. Krohne invoices for sales to \_\_\_\_\_ do not allow for computation of prices, since the net amounts due on these invoices represent aggregate sales of more than one size of flowmeters, including sales of under 2 inches. However, the invoices do allow for computation of the units sold by Krohne to \_\_\_\_\_ which included during April-October 1984, five 4-inch ALTOFLUX X-1000 flowmeters, two 3-inch ALTOFLUX X-1000 flowmeters, and three 2-inch ALTOFLUX X-1000 flowmeters. (CPX-30, at 900045, 900123, 900239-40, 900243-44).

#### Brunswick Paper

578. In May 1984, Brunswick Paper was having applications problems with F&P MINI-MAGs. F&P believed at that time that use of the F&P ceramic-lined flowmeter would solve Brunswick Paper's application problem. (RX-29 at 05590).

579. In March 1985, F&P exchanged 10 ceramic lined K-MAGs for the MINI-MAGs it had sold to Brunswick Paper, at no extra charge. These included 6 flowmeters of diameters 2 inches and over. (RX-30).

580. Brunswick Paper has purchased no flangeless magnetic flowmeters over 2 inches in diameter from Krohne. (See FF 563(a)).

581. Purchase orders issued to Krohne from \_\_\_\_\_ from June 4, 1985, to September 26, 1985, were based on competitive bids. F&P, Krohne and Rosemount had submitted bids for this order, and Krohne submitted an addendum bid. Krohne was awarded the order based on the lowest price. Rosemount was the next lowest bidder to Krohne. The F&P meters included one MINI-MAG with TEFZEL liner and one K-MAG with a ceramic spool (both remote mounted). The Krohne meters were ALTOFLUX X-1000 meters. The Krohne meters included two

3-inch flowmeters, quoted at \$2,862 each, and a spare 3-inch primary, quoted at \$1,556.40. The F&P bid was for a 3-inch Tefzel meter, and for a 3-inch ceramic meter. (RRPX-3, Turner Dep. at 12-16, 29-31; CPX-33, Dep. Exhs. 7063-7068, 7070, 7075).

582. In June-July 1985, purchased two 3-inch ALTOFLUX X-1000 flowmeters from Krohne for \$2,902 each. (CPX 30 at 900497).

583. In August-September 1985, purchased two 2-inch ALTOFLUX X-1000 primaries, one for \$1,556.40 and one for \$1,596.40. (CPX-30 at 900534, 900505).

584. As of May 1986, had approximately 20 magnetic flowmeters at its facility. Of electromagnetic flowmeters in service at approximately six were from Krohne, approximately 12 were from F&P, and two or three were from Honeywell and Foxboro. Such flowmeters are used primarily for slurries, and occasionally for liquids that solidify when cooled. (CPX-33, Rhodes Dep. at 3-5).

585. In June 1985, F&P listed a competitive bid situation to where it bid percent below its list price for a sale of three 2-inch K-MAG flowmeters, valued at (SX-13 at 03376).

586. In June 1985, F&P listed a competitive bid situation to where it bid percent below its list price for a sale of MINI-MAG flowmeters, valued at The competitors listed were Foxboro and Krohne. (SX-13 at 03376).

587. In December 1985, F&P listed a competitive bid situation to where F&P bid percent below its list price for a sale of K-MAG flowmeters, valued at The size of the flowmeter was not listed. The competitor listed was Krohne. (SX-12 at 04726).

588. In one situation in 1986, Krohne flowmeters were specified by an

engineer to replace F&P K-MAG flowmeters because of technical problems with the F&P meters associated with installation and calibration. (RRPX-2, Meader Dep. at 44-45; RRPX-4, Dep. Exh. 7010).

589. In another bid situation at in early 1984, F&P 3-inch MINI-MAGs were purchased over those of other companies. In the specifications by steam-out capability was required. F&P's price for an individual integral flowmeter was F&P's total bid, which included items other than magnetic flowmeters, was the lowest and Krohne's bid was the highest. Krohne's bid, which involved its ALTOFLUX X-1000, was percent higher than F&P's bid. Foxboro's bid was percent higher and Rosemount's bid was percent higher than F&P's bid. (RRPX-2, Meader Dep. at 44; CPX-30, Dep. Exhs. 7007-7008).

590. purchases electromagnetic flowmeters only from Krohne and F&P. (CPX-31, Marshall Dep. at 24).

591. In 1980 or 1981, decided to switch sourcing electromagnetic flowmeters from F&P to Krohne. The Krohne meters replaced the F&P meters. Price was not a factor in this decision. The reason for purchasing the Krohne meters was that they were more accurate in their measurements. (CPX-31, Marshall Dep. at 26-30).

592. In March 1984, Krohne sold a 2-inch DELTAFLUX flowmeter for (CPX-31, Dep. Exh. 8014).

593. In June 1984, purchased a Krohne 3-inch DELTAFLUX flowmeter for , not including shipping and insurance. (CPX-31, Dep. Exh. 8019).

594. In June 1985, Krohne sold a 2-inch DELTAFLUX flowmeter for and a 3-inch DELTAFLUX flowmeter for (CPX-31, Dep. Exh. 8012).



595. In the course of purchasing flangeless magnetic flowmeters, solicits alternative bids to get comparison pricing, including prices from F&P and Krohne. On occasion, purchases Krohne flowmeters instead of F&P flowmeters for the same application, if the Krohne price is better. According to the purchaser, prices from all suppliers are pretty much the same, with a few hundred dollars difference. (CPX-32, Mullin Dep. at 20-21, 36-37).

596. In October 1984, purchased a 2-inch Krohne DELTAFLUX flowmeter for including the signal converter and cable. (CPX-32, Dep. Exh. 6010; CPX-30 at 900013).

597. In December 1984, purchased four Krohne 4-inch ALTOFLUX X-1000 primaries, a 3-inch ALTOFLUX X-1000 primaries, a 2-inch ALTOFLUX X-1000 primary, and six T-900 signal converters. The price for the primaries included cable. Based on the primary and signal converter price, the total unit cost to was for the 4-inch ALTOFLUX, for the 3-inch ALTOFLUX, and for the 2-inch ALTOFLUX. (CPX-30 at 900036; See: CPX-32, Mullin Dep. at 25-26; CPX-32, Dep. Exh. 6004).

598. sells Krohne flangeless magnetic flowmeters to its customers. Based on price list as of June 1984, its sales price for its ALTOFLUX X-1000 flowmeters, with standard specifications, was for the 2-inch flowmeter, for the 3-inch flowmeter, and for the 4-inch flowmeter, a markup of about percent over the prices for each of the meters in the previous finding. (CPX-32, Mullin Dep. Exh. 6000).

599. In January 1985, purchased from Krohne eight 3-inch DELTAFLUX flowmeters for apiece, and fifteen 4-inch DELTAFLUX

flowmeters for                      apiece, including signal converter and cable.

(CPX-30 at 900341; See CPX-32, Dep. Exh. 6013).

600. In April 1985,                                      purchased a 3-inch DELTAFLUX  
flowmeter from Krohne for                      including the signal converter and cable.

(CPX-30 at 900420; See CPX-32, Dep. Exh. 6006).

601. In May 1985,                                      purchased two 2-inch ALTOFLUX X-1000  
flowmeters from Krohne, including signal converter and cable, for  
apiece. (CPX-32, Dep. Exh. 6007).

602. In August 1985,                                      purchased two 2-inch DELTAFLUX  
flowmeters from Krohne for                      apiece, including the signal converter and  
cable. (CPX-32, Dep. Exh. 6014).

603. In February 1985,                                      purchased a 3-inch primary from  
Krohne for                      (CPX-30 at 900361).

604. In mid-1983 Krohne had entered into an OEM agreement with  
                    whereby Krohne would market Krohne magnetic flowmeters under the  
Krohne label, principally in system sales. The OEM agreement was  
non-exclusive and did not preclude Krohne-America from competing with  
for the same business. (SX-25).

604(a). The O.E.M. agreement was entered into by Krohne-America and  
  
The agreement covers the purchase from Krohne by                      of instruments for  
resale and of instruments parts, including the ALTOFLUX X-1000 (primary);  
DELTAFLUX DEF-200 (primary and converter 200); ALTOFLUX K-300 (Flowmeter  
series); T-900 (converter for magnetic flowmeters); M-949,950,960 (magnetic  
flowmeters). The agreement is effective for one year from the last date of  
execution, and is automatically renewed from year to year thereafter. The

agreement can be terminated without cause by either party upon 90 days notice, prior to the expiration of the current term. The agreement can be terminated for cause at any time, with some restrictions on such termination. (Notice of default, opportunity to cure, ect.) The right of to distribute the above mentioned products is on a non-exclusive basis in the United States. Krohne acknowledges that the products ordered and sold under the agreement are an integral part of offering to its customers and promises to expend its best efforts to a continuous supply of those products and related parts so long as the agreement is in effect. Krohne guarantees a supply of spare parts for a period not exceeding 6 years following the termination of a products manufacturing. (CX-53).

605. In January 1984, purchased a Krohne 2-inch DELTAFLUX flowmeter for including converter and cable. (CPX-30 at 900146).

606. In February 1984, purchased a Krohne 2-inch DELTAFLUX flowmeter for and a 3-inch DELTAFLUX for including converter and cable. (CPX-30 at 900198-99).

607. In April 1984, purchased two Krohne 2-inch DELTAFLUX flowmeters for including converters and cable. (CPX-30 at 900237-38).

608. In July 1984, purchased two Krohne 2-inch Krohne DELTAFLUX flowmeters from for per meter, including converter and cable. (CPX-30 at 900067).

609. In April 1985, purchased a Krohne 2-inch Krohne DELTAFLUX flowmeter for including converter and cable. (CPX-30 at 900416).

610. In July 1985, F&P quoted to a price of for a 2-inch MINI-MAG with zirconium electrodes. (CX-107, Quotation No. 5-164-42).

611. In July 1985, purchased three Krohne 2-inch DELTAFLUX flowmeters for per meter, including converter and cable. (CPX-30 at 900486).

612. In August 1985, F&P sold a 3-inch MINI-MAG with zirconium electrode to for (CX-107, Purchase Order No. 03-12531).

613. In December 1985, F&P sold to a 2-inch MINI-MAG with zirconium electrodes for and a 4-inch MINI-MAG with zirconium electrodes for (CX-107, Purchase Order Nos. 03-13082, 03-12533).

614. In May 1984, purchased a 2-inch Krohne DELTAFLUX flowmeter for (including converter and 30' of cable), and paid for an additional 100 feet of cable. also purchased a 3-inch DELTAFLUX for and a 4-inch DELTAFLUX for (CPX-30 at 900294, 900274-75).

615. In November 1984, purchased a Krohne 4-inch ALTOFLUX X-1000 flowmeter for including converter and cable. (CPX-30 at 900021).

616. In December 1984, purchased two 3-inch Krohne DELTAFLUX flowmeters for including converter and cable. (CPX-30 at 900024).

617. In April 1985, purchased a 3-inch Krohne DELTAFLUX flowmeter for and a 2-inch DELTAFLUX flowmeter for (CPX-30 at 900409, 900422).

618. In October 1985, purchased a Krohne 4-inch ALTOFLUX X-1000 for and a 3-inch DELTAFLUX for including converters and cable. (CPX-30 at 900544-545).

619. In December 1985, purchased a Krohne 2-inch DELTAFLUX flowmeter for including converter and cable. (CPX-30 at 900588).

620. In June 1984, purchased a Krohne 3-inch DELTAFLUX flowmeter for including converter and primary. (CPX-30 at 900328).

621. In September 1984, purchased a Krohne 2-inch ALTOFLUX X-1000 flowmeter for including converter and cable. (CPX-30 at 900100).

622. In April 1985, purchased three Krohne 3-inch ALTOFLUX X-1000 flowmeters for apiece, including converter and cable. (CPX-0 at 900425).

623. In June 1985, purchased a Krohne 4-inch ALTOFLUX X-1000 flowmeter for including converter and cable. (CPX-30 at 900457).

624. In May 1985, purchased nine Krohne 3-inch ALTOFLUX X-1000 flowmeters for apiece, including converter and cable. (CPX-30 at 900454).

625. In February 1984, purchased two Krohne 3-inch ALTOFLUX X-1000 flowmeters. However, the individual unit pricing for these flowmeters was not provided. (CPX-30 at 900205-06).

626. In December 1984, purchased a Krohne 2-inch ALTOFLUX X-1000 flowmeter for including converters and cable. (CPX-30 at 900029).

627. In June 1985, purchased a Krohne 3-inch ALTOFLUX X-1000 flowmeter for including converter and cable. (CPX-30 at 900472).

628. In August 1985, purchased a Krohne 3-inch DELTAFLUX flowmeter for including converter and cable. (CPX-30 at 900501).

629. In September 1985, purchased a Krohne 3-inch ALTOFLUX X-1000 flowmeter for and a 3-inch DELTAFLUX for including converters and cable. (CPX-30 at 900536, 900520).

630. In September 1985, purchased five Krohne 2-inch ALTOFLUX X-1000 flowmeters for and two Krohne 3-inch ALTOFLUX X-1000 flowmeters for (CPX-30 at 900539-40).

631. In August 1984, purchased two Krohne 2-inch DELTAFLUX flowmeters, two 3-inch DELTAFLUX, and two 4-inch DELTAFLUX. However, meters of other sizes were included in the total amount owed, so individual prices were not shown. (CPX-30 at 900070-71).

632. In December 1984, purchased a Krohne 2-inch DELTAFLUX flowmeter for and a 4-inch DELTAFLUX for including converters and cable. (CPX-30 at 900023, 900025).

Other Competition

633. used Foxboro magnetic flowmeters when its original mill was built in 1972, and use all F&P magnetic meters when it expanded its plant in 1978. The F&P flowmeters used in 1978 were the Mag X meters, which are flanged. bought all its size requirements from the same manufacturer for each stage. ( , Tr. at 914-916).

634. For replacements, purchases F&P flowmeters to replace F&P flowmeters and Krohne flowmeters to replace Krohne flowmeters. ( , Tr. at 917-918).

635. Of 53 entries for which a competitor or competitors were identified in F&P's records regarding quotes for its MINI-MAG or K-MAG, 22 references were to competitors who either do not produce flangeless magnetic flowmeters or magnetic flowmeters. These companies included Foxboro, Rosemount, Taylor, Smith and Sparling. (SX-12; SX-13).

636. Complainant has offered MINI-MAGs and/or K-MAGs in competition with companies that do not produce flangeless or magnetic flowmeters. (SX-12; SX-13; Dimm, Tr. at 484; RX-65 at 007002).

637. In selling its ALTOFLUX X-1000 and DELTAFLUX, Krohne has faced competition from Brooks, Foxboro, Rosemount, Taylor and F&P. Foxboro, Rosemount and Taylor offer flanged rather than flangeless flowmeters. (RX-1, Beahm WS at 28; RX-2, Esposito WS at 14(b); RX-8, Mannion WS at 4-5; RX-9, Seelaus WS at 3; RX-10, Williams WS at 2).

638. F&P's major competitors in the magnetic flowmeter market for flowmeters from two to four inches in diameter are Rosemount, Krohne, Brooks and Foxboro. (Dimm, Tr. at 484).

639. Flowmeters produced by Brooks, Rosemount and Foxboro compete in the marketplace with MINI-MAG and K-MAG flowmeters produced by F&P. (Reister, Tr. at 472-473; Dimm, Tr. at 484).

640. In March 1984, an F&P employee did a competitive assessment of flowmeters produced by Brooks. Brooks introduced a flangeless flowmeter in the fall of 1982 (the 7400 series), about a year and a half after F&P had introduced its MINI-MAG flowmeter. (RX-43 at 00889-891).

641. The major differences between the Brooks and F&P flangeless flowmeters in March 1984 was that the Brooks accuracy was slightly better, and the Brooks meter used an aluminum rather than a carbon steel coil housing. (RX-43 at 00897).

642. In March 1984, Brooks' list prices for a flangeless flowmeter of 2 inch diameter was less than F&P's list price of \$2,675. F&P observed that Brooks often priced its magnetic flowmeters at percent below F&P's list prices. F&P was prepared to discount its MINI-MAG accordingly when necessary. (RX-43 at 00898).

643. In June 1985, an F&P employee performed another evaluation of Brooks' flangeless magnetic flowmeters. It concluded that the Brooks meter was a good flowmeter and should be more than adequate for many applications. The major disadvantages of the Brooks meter was its aluminum housing (less rugged than carbon steel and more magnetic interference from spanning bolts), and the design of the magnet coil. (RX-44 at 00932-936).

644. In May 1983, Krohne was competing with F&P in Florida for water and waste jobs. The type or size of the meters involved was not specified. (SX-11 at 006691).



645. In late 1984, magmeters from Brooks and Krohne were considered by F&P to be its main competitors in the Southwest sales region. (SX-8 at 006814; SX-9 at 006779).

646. In December 1984, F&P lost a sale of AC MINI-MAGs to Foxboro, because Foxboro was 5 percent lower priced despite F&P's heavy discounting. No information was provided in this document concerning the size of the meters involved. (RX-47 at 05555).

647. In December 1984, F&P lost a sale of 129 MINI-MAGs to Brooks. After discounting      percent, F&P's bid was      per meter, and Brooks still undersold F&P by      per meter to win the bid. No information was provided in this document concerning the size of the meters involved. (RX-47 at 05555; See RX-50 at 006806).

648. In March 1985, Brooks was competing against F&P for sales of flangeless flowmeters to Burlington Industries. The Brooks offer was      per meter, compared to F&P's bid of      which was      percent below F&P's list price. The size of the meters involved was not specified. (RX-48 at 007077).

649. In March 1985, Brooks was competing against F&P for sales of flangeless flowmeters to Marathon Cody. After F&P's discount of      percent below list, the Brooks quote was still      percent lower than F&P's quote. (RX-49 at 007087).

650. In December 1984, F&P lost an order to Rosemount for sales of its AC MINI-MAG. Rosemount underbid both F&P and Foxboro. (RX-56 at 05549).

651. In September 1985, F&P's magnetic and vortex flowmeters were facing competition in the Southeast region from Brooks, Krohne, Kent, Micro Motion and Poly Sonic. The most intense competition was from Micro Motion's mass flowmeter and Poly Sonic's ultrasonic flowmeter. (RX-65 at 007002).



656. Krohne's list prices for its ALTOFLUX X-1000 (0.5 percent accuracy) and DELTAFLUX (2.0 percent accuracy) flowmeters, issued in October 1983, are as follows:

	<u>ALTOFLUX X-1000</u>	<u>DELTAFLUX</u>
2 inches-----		
3 inches-----		
4 inches-----		

(SX-26 at 500124-25).

657. For sales of the primary only, the list price of for the F-200 signal converter would be deducted from the DELTAFLUX prices in the previous finding. For the ALTOFLUX X-1000, the list price of for the T-900 signal converter would be deducted from the list price. (SX-26 at 500124-25).

658. Inquiries representing

(SX-26 at 500126).

659. The DELTAFLUX and ALTOFLUX X-1000 come only in "remote" versions wherein the electronic package is mounted separately from the primary. (SX-33 at 501615; SX-34 at 501605; Beahm, Tr. at 1041-1042).

660. Prior to Krohne's discount multiplier to be applied to its list prices was This would result in the effective list prices below:

	<u>ALTOFLUX X-1000</u>	<u>DELTAFLUX</u>
2 inches-----		
3 inches-----		
4 inches-----		

(SX-26 at 500124-25; RRX-10 at 501808).

661. With commissions of less than percent, the discount from the list price would be greater. For example, with a commission of percent, the

discount multiplier to be applied to the list price would be (SX-28 at 900608).

662. Annual unit values for Krohne America's actual sales of ALTOFLUX X-1000 and DELTAFLUX magnetic flowmeters from 1983 to January-November 1985 were as follows:

	<u>1983</u>	<u>1984</u>	<u>1985</u>
ALTOFLUX X-1000:			
2 inch-----			
3 inch-----			
4 inch-----			
DELTAFLUX:			
2 inch-----			
3 inch-----			
4 inch-----			

(RRX-12).

663. The average unit values above include sales of the primary only as well as of the primary/remote electronic package, and therefore underestimate the actual unit value of the primary/remote electronic package. In 1985, of the ALTOFLUX X-1000 units sold, were of the primary only; of the DELTAFLUX units sold, were of the primary only. In 1984, of the ALTOFLUX X-1000 units sold, were of the primary only; of the DELTAFLUX units sold, were of the primary only. The invoices for 1983 were not complete and therefore such an analysis cannot be done for this year. When sales of the primary only are factored out of the above unit values for 1984 and 1985, actual sales unit values for the primary/remote electronic package are as follows:

	<u>1983 1/</u>	<u>1984 2/</u>	<u>1985 2/</u>
ALTOFLUX X-1000:			
2 inch-----			
3 inch-----			
4 inch-----			

DELTAFLUX:  
 2 inch-----  
 3 inch-----  
 4 inch-----

- 1/ Sales of the primary only not factored out of the average unit value.  
2/ Sales of the primary only factored out of the average unit value.

(RRX-12; CPX-30).

664. In addition to the invoice price paid by a customer for a Krohne magnetic meter, a customer must pay for the installation of the remote electronics, which was from \_\_\_\_\_ for one customer depending on whether a floor mounted pipe was required. (RRX-7 at 2; RRX-9; Beahm, Tr. at 1056-1058).

665. Effective \_\_\_\_\_ Krohne's discount multiplier for the lower accuracy DELTAFLUX (2 percent accuracy), to \_\_\_\_\_ for the higher accuracy DELTAFLUX (1 percent accuracy), and to \_\_\_\_\_ for the ALTOFLUX X-1000, given a commission of \_\_\_\_\_. The increase in the discount multiplier was the result of an increase in Krohne's costs. This change in the discount multiplier would result in the following effective list prices:

	<u>ALTOFLUX X-1000</u>	<u>DELTAFLUX</u>	<u>DELTAFLUX</u>
2 inches-----			
3 inches-----			
4 inches-----			

(SX-26 at 500124-25; RRX-10 at 501808).

666. F&P's current list prices for its MINI-MAG and K-MAG flowmeters, with integral electronics, is as follows:

	<u>MINI-MAG</u>	<u>K-MAG</u>
2 inches-----	\$2,595	\$3,400
3 inches-----	2,770	3,550
4 inches-----	2,870	3,700

(SX-21 at 007429; SX-22).

667. F&P offers a competitive discount of            on its magnetic flowmeters. In addition, it offers volume discounts that have ranged from 12 to 34 percent. (SX-6, Ans. to Int. No. 6; See SX-12, SX-13; Dimm, Tr. at 488-489).

668. The MINI-MAGs and K-MAGs may be purchased in two forms: (1) an integral unit where the electronic package, which processes the signal to provide the final meter output, is mounted directly on the primary, the device which is inserted in the pipe line; and (2) a remote system where the electronic package is located away from the primary. For both the MINI-MAG and K-MAG, F&P charges an additional \$320 for a remote electronic flowmeter. Approximately            percent of F&P's customers purchase its electromagnetic flowmeters with remote electronics. (SX-15 at 501317-18; SX-16 at 501365-66; SX-21 at 007430; SX-22; Dimm, Tr. at 483-484, 492-494, 508, 513; RPX-1, Dimm Dep. Tr. at 81).

669. The customer would have to incur a separate cost to mount an F&P flowmeter with the remote electronics, in addition to the \$320 charge. In responding to a question concerning the cost to a customer for buying an F&P remote flangeless flowmeter, Mr. Dimm responded: "There are two factors, I believe, that are involved there. One would be the additional cost of installation by that customer, and that same cost would apply no matter whether it was a Krohne or a F&P device, as well as an additional charge that we charge our customers due to the increase in cost of the device." This installation charge would range from \$50 to \$600 depending on distances involved. (Dimm, Tr. at 483-484).

670. Krohne magnetic flowmeters are offered with remote electronics only, and may not be competitive with F&P flowmeters where integral electronics are required or preferred. The advantages of an integral

flowmeter include: lower installation costs since only one component has to be mounted; the problem of interference in a connecting cable between the primary and the remote is eliminated; for people unfamiliar with the installation, there is no need to search for the electronics. The advantages of a remote flowmeter include: the electronics can be located in a convenient, accessible location; the electronics can be removed from an inhospitable environment; less room is required above the pipe to mount the meter. (RX-3, Liptak WS at 26-29; See RX-1, Beahm WS at 21; See Foster, Tr. at 868).

671. For a surcharge of \$500, F&P offers a high accuracy option for its K-MAG, which would give it the same accuracy (0.5 percent) as Krohne's ALTOFLUX X-1000. (Dimm, Tr. at 508, 512-513).

672. SX-12 and SX-13 are F&P management pricing control logs, which list F&P's quotes, competitors, and discounts for different types of flowmeters. For the MINI-MAG and K-MAG, the following were F&P's discounts in 1985, when faced with competition from various suppliers:

<u>Competitor(s)</u>	<u>Average F&amp;P Discount 1/</u>	<u>Discount Range</u>	<u>Number of Quotes</u>
Krohne only-----			
Krohne and other(s)-----			
Brooks only-----			
Foxboro only-----			
Yokogawa-----			
Multiple suppliers <u>2/</u> -----			
No competition listed-----			

1/ A weighted average, with the discounts weighted by the quote values. (SX-12, SX-13).

2/ Not including Krohne.

673. For only one quote when F&P listed Krohne as the competitor, was the size of the flowmeter given. For this quote, which represented sales of three 2-inch K-MAGs, F&P discounted      percent. (SX-13 at 03376).

674. In 1985, SX-12 and SX-13 lists four quotes involving the K-MAG flowmeter. Krohne was listed as the competitor in three of these four quotes, and F&P's average discount was percent. For the one other quote, both Foxboro and Brooks were listed as the competitors, and F&P's discount was percent. (SX-12 at 04726; SX-13 at 03372, 03375, 03376).

TENDENCY TO SUBSTANTIALLY INJURE

675. The manufacturing costs for Krohne's flangeless electromagnetic flowmeters are as follows:

	<u>Size</u> <u>(Inches)</u>	<u>Cost (Sfr) 1/</u>	<u>Cost 1 2/</u> <u>(dollars)</u>
ALTOFLUX X-1000:	2		
	3		
	4		
DELTAFLUX:	2		
	3		
	4		

These manufacturing cost are based on direct material and labor costs and associated overhead charges, and related costs for production tools.

1/ Swiss francs.

2/ Based on the average exchange rate of 2.069 Swiss francs per dollar in January 1986. (SX-47).

(SX-3, Ans. Int. No. 8(d)).

676. The manufacturing costs for the ALTOFLUX X-1000 and DELTAFLUX includes only the cost of the primary units. It does not include the cost of the converter. (SX-47A).



677. F&P's manufacturing costs for its MINI-MAG (for both zirconium and tantalum electrodes) and K-MAG (platinum electrodes) flowmeters for sizes 2 inches to 4 inches is as follows:

	<u>MINI-MAG</u>		<u>K-MAG</u>
	<u>Zirconium</u>	<u>Tantalum</u>	
2 inch-----			
3 inch-----			
4 inch-----			

(SX-5, Ans to Int. No. 7(f)).

678. F&P's manufacturing costs do not make a breakout between the cost of the primary and the cost of the integral electronic converter. (CX-4, Stewart WS at 5).

679. The annual production capacity for respondent's flangeless electromagnetic flowmeters for worldwide distribution is about            units. In 1985, total production was about            units. Krohne Germany asserts that

(Beahm, Tr.

at 1065; SX-3, Ans. Int. No. 5; CPX-11, Focks Dep. at 71-72).

680.

(Beahm, Tr. at 1061-1063, 1066, 1068).

681. Because Krohne GmbH. and Rheometron manufacture flangeless flowmeters for many markets throughout the world, Krohne America has had difficulty in the past in obtaining flowmeters to meet customer demand. (RX-1, Beahm WS at 11).

682. Krohne Messtechnik GmbH. & Co.'s sales and profits for sales to Krohne America, Inc. since 1983 are as follows (in dollars and units):

	<u>1983</u>	<u>1984</u>	<u>Jan.-Oct. 1985</u> <sup>1/</sup>
ALTOFLUX X-1000:			
Sales-----			
Gross Profits---			
Units-----			
 DELTAFLUX:			
Sales-----			
Gross Profits---			
Units-----			

(SX-3, Ans. Int. No. 8(f); SX-47).

<sup>1/</sup> The January-October 1985 exchange rate used was 2.5251 Francs/Dollar, a weighted average of the exchange rates of the first three quarters of 1985 and of October 1985.

683. Krohne Messtechnik's net profits would be calculated by subtracting from gross profit the following costs: freight and handling; general overhead costs; selling and administrative expenses; research and development costs; and depreciation. (SX-3, Ans. Int. No. 14(g)).

684. Krohne America estimates its usage of flangeless magnetic flowmeters on the basis of past sales, and places orders with Krohne GmbH. accordingly. (RX-1, Beahm WS at 12).

685. Respondents are considering producing and/or assembling the accused product in the United States. (CPX-2, Beahm Dep. at 59-62, 71; RX-113 at Stipulation 4; RX-1, Beahm WS at 13; RX-69).

686. Krohne America has included in its "Capital Expenditures Budget" for 1986 a \_\_\_\_\_ that

would be used for domestic production of ALTOFLUX X-1000 and DELTAFLUX magnetic flowmeters. (RX-1, Beahm WS at 13; RX-70).

687. Krohne presented or demonstrated its flangeless flowmeters at industry or trade shows in the following cities:

Philadelphia, PA:	October 1982; October 1985
Houston, TX:	March 1983; October 1983; October 1984
Boston, MA:	May 1985
Richmond, VA:	Spring 1982
Winston-Salem, NC:	Spring 1984
Birmingham, AL:	Spring 1985
Miscellaneous local shows	

(SX-1, Ans. Int. No. 30(a)).

688. From the date Krohne instituted research and development for flangeless flowmeters until January 1986, Krohne has spent on flangeless flowmeter R&D. (SX-2, Ans. Int. No. 31(a-d)).

689. Based on Krohne GmbH.'s sales to Krohne America, and Krohne America sales in the United States through March 1986, Krohne America would have had flowmeters in inventory as of March 1986. If the size distribution of this inventory were comparable to Krohne's sales, percent of this inventory, or meters, would be in the size range of 2-4 inches in diameter. (FF. 445, 493).

690. Krohne America has a network of independent sales representatives in the United States. (CPX-1, Esposito Dep. at 68).

691. Krohne America predicts that its gross United States sales will from in 1985 to between in 1986. However, Krohne America's flangeless magnetic flowmeter sales, 2-4 inches in diameter, accounted for only about of this total in 1985. (CX-2, Beahm Dep. at 167-68).

692. Krohne GmbH. uses modern equipment in the development, manufacture, testing, and repair of its flangeless electromagnetic flowmeters. (SX-3, Response to Int. Nos. 4(a-b)).

CONCLUSIONS OF LAW

1. The Commission has in rem jurisdiction and subject matter jurisdiction in this investigation.
  
2. The Commission has in personam jurisdiction over each of the respondents in this investigation.
  
3. Claims 1, 2, 3, 4 and 5 of the '982 patent are not invalid under 35 U.S.C §§ 102, 103 and 112.
  
4. Claims 1, 2, 3, 4 and 5 of the '982 are not unenforceable and/or not invalid due to any lack of fair and full disclosure to the Patent Office.
  
5. Krohne's flangeless electromagnetic flowmeters having less than 2 inch conduit diameter do not infringe claims 1, 2 and 5 of the '982 patent.
  
6. Krohne's flangeless electromagnetic flowmeters having a two to four inch conduit diameter do infringe claims 1, 2, 3, 4, and 5 of the '982 patent.
  
7. There is a domestic industry consisting in the manufacture of flangeless electromagnetic flowmeters of 2 to 4 inch conduit diameter which domestic industry is efficiently and economically operated.

8. Importation of flangeless electromagnetic flowmeters having a two to four inch conduit diameter made by claims 1, 2, 3, 4 and 5 of the '982 patent has the effect of substantially injuring the domestic industry.

9. Importation of flangeless electromagnetic flowmeters having a two to four inch conduit diameter made by claims 1, 2, 3, 4 and 5 of the '982 patent has the tendency to substantially injure the domestic industry.

10. There is a violation of section 337 by each of the respondents.

INITIAL DETERMINATION AND ORDER

Based on the foregoing findings of fact, conclusions of law, the opinion and the record as a whole, and having considered all of the pleadings and arguments presented orally and in briefs, as well as proposed findings of fact and conclusions of law, it is the administrative law judge's determination that there is a violation of section 337 in the unauthorized importation and sale in the United States of certain flangeless electromagnetic flowmeter having a two to four inch conduit diameter.

The administrative law judge hereby CERTIFIES to the Commission the initial determination, together with the record of the hearing in this investigation consisting of the following:

1. The transcript of the hearing, with appropriate corrections as may hereafter be ordered by the administrative law judge; and
2. The exhibits admitted into evidence.

The pleadings of the parties are not certified, since they are already in the Commission's possession in accordance with Commission Rules of Practice and Procedure.

Further it is ORDERED that:

1. In accordance with Rule 210.44(b), all material heretofore marked in camera because of business, financial, and marketing data found by the administrative law judge to be cognizable as confidential business information under Rule 201.6(a), is to be given in camera treatment from the date this investigation is terminated; and further
  
2. Counsel for the parties shall have in the hands of the administrative law judge those portions of this initial determination which contain confidential business information to be deleted from the public version initial determination no later than Friday August 8, 1986. If no comments are received from a party it will mean that the party has no objection in removing the confidential status, in its entirety, from this initial determination.
  
3. Motion No. 229-6 is denied.
  
4. Motion to strike the testimony relating to the Krohne flowmeter of conduit less than 2 inch diameter is denied.
  
5. Motion for production of certain attorney client documents of complainant is denied.
  
6. This initial determination shall become the determination of the Commission forty-five (45) days after the service thereof, unless the Commission, within forty-five (45) days after the date of filing of the

Initial Determination s. I have ordered review of the Initial Determination or certain issues therein pursuant to 19 C.F.R. 210(b) or 210.55 or by order shall have changed the effective date of the initial determination.

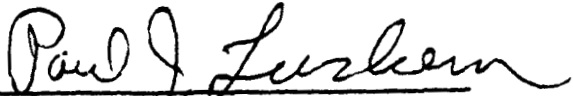
  
Paul J. Lockern  
Administrative Law Judge

Issued: July 30, 1986



